



PHILIP

IEEE-488/IEC-625 BUS Interface
and RS232-C/V24 BUS Interface for
Digital Storage Oscilloscope PM3320A and
2 GHz Digitizing Oscilloscope PM3340
PM8956A/01

4822 872 03345
890201

Instru  tic

NOTE:

The design of this interface is subject to continuous development and improvement. Consequently, this interface may incorporate minor changes in detail from the information contained in this manual.

CONTENTS	Page
1. INTRODUCTION	1-1
1.1 How to use this manual	1-1
2. INSTALLATION INSTRUCTIONS	2-1
2.1 Initial inspection	2-1
2.2 Removing the instrument covers	2-3
2.3 Installing the P.C.B.'s and the cables	2-4
2.4 Installing the instrument covers	2-5
2.5 Settings of the interface	2-5
3. OPERATING INSTRUCTIONS INCLUDING REAL TIME CLOCK, DIGITAL PLOT AND USER TEXT	3-1
3.1 Switching-on and power up routine	3-1
3.1.1 Switching on	3-1
3.1.2 Power-on routine	3-1
3.1.3 Default settings after switching-on	3-1
3.2 Additional features	3-2
3.3 Explanation of optional control and option menu structure	3-2
3.4 Digital plot and print modes	3-20
3.4.1 Digital plot specification	3-20
3.4.2 Digital print specification	3-24
3.4.3 Digital plot and print menus	3-26
4. IEEE-488/IEC-625 INTERFACE	4-1
4.1 Introduction	4-1
4.2 Structure of the IEEE-488/IEEE-625 bus	4-2
4.3 Bus-line functions	4-4
4.4 The handshake procedure	4-5
4.5 Addressing	4-6
4.6 Address setting	4-7
4.7 SRQ-service request and serial polling	4-11

	Page
4.8	The device status word 4-13
4.9	The device status register and the device status enable register 4-15
4.10	Data transfer rate and timing specifications 4-17
4.11	Interface function repertoire 4-24
4.12	Electrical specifications 4-24
4.13	Mechanical specifications 4-24
4.14	Specification IEEE-488/IEC-625 interface 4-26
4.15	ISO-code table 4-27
4.16	Multi line messages 4-28
4.16.1	GO TO LOCAL command 4-28
4.16.2	GROUP EXECUTE TRIGGER command 4-28
4.16.3	SELECTIVE DEVICE CLEAR command 4-28
4.16.4	DEVICE CLEAR command 4-29
5.	RS232-C/V24 INTERFACE 5-1
5.1	Introduction 5-1
5.2	Definition of the RS232-C interface 5-1
5.3	Data transmission 5-1
5.3.1	Synchronization 5-2
5.3.2	Character length 5-2
5.3.3	Baudrate 5-2
5.3.4	Interface transmission modes 5-2
5.4	Initial setting 5-3
5.5	Special interface functions 5-7
5.5.1	Service request and serial polling 5-7
5.5.2	Remote local protocol 5-8
5.5.3	Device clear 5-8
5.5.4	Device trigger 5-8
5.6	Data transfer rate calculation 5-10
5.7	Electrical specifications 5-12
5.8	Mechanical specifications 5-12
5.9	RS232-C connector 5-13

	Page
6. PROGRAMMING AN OSCILLOSCOPE	6-1
6.1 Description of possible actions	6-1
6.2 Message protocol for oscilloscopes	6-2
6.2.1 Introduction	6-2
6.2.2 Separators	6-3
6.2.3 Message units	6-4
6.3 Oscilloscope programming	6-6
7. PROGRAMMING CODES	7-1
7.1 System codes	7-2
7.1.1 Separator	7-2
7.1.2 Block separator	7-3
7.1.3 Unit separator	7-4
7.1.4 Call for identity	7-5
7.1.5 Wait time delay	7-5
7.1.6 Bus learn	7-6
7.1.7 Number representation	7-7
7.2 Super function codes	7-8
7.2.1 Super function codes available for this oscilloscope	7-8
7.3 Main function codes and low function codes	7-8
7.3.1 Main functions available for this oscilloscope	7-8
7.3.2 ALL main functions	7-9
7.3.3 Main function VERTICAL	7-10
7.3.4 Main function HORIZONTAL	7-18
7.3.5 Main function MISCELLANEOUS	7-30
7.3.6 Main function SPECIAL	7-50
7.4 Error codes	7-70
8. PROGRAMMING EXAMPLES	8-1
8.1 Introduction	8-1
8.2 Driver programs	8-1
8.2.1 Driver program HP85 (IEEE)	8-1
8.2.2 Driver program IBM (IEEE)	8-2
8.2.3 Driver program IBM (serial)	8-3
8.2.4 Driver program P2000C (IEEE)	8-4

	Page
8.3	How to use the driver programs? 8-5
8.4	Programming exercises 8-7
8.4.1	Text 8-7
8.4.2	Data transfer 8-10
8.4.3	Dumping data to a printer (serial printer) 8-10
8.4.4	Use of UP/DOWN/NORMAL + SRQ 8-11
8.4.5	Front settings 8-12
8.4.6	Register savings 8-13
8.4.7	Event counting 8-14
8.4.8	Plotting register \emptyset , using a controller 8-15
8.4.9	Bus learn 8-14
9.	CHARACTERISTICS OF IEEE-488/IEC-625, RS232-C/V24 INTERFACES AND REAL TIME CLOCK 9-1
9.1	IEEE-488/IEC-625 interface 9-1
9.2	RS232-C interface 9-2
9.3	Real time clock 9-3
9.4	Front panel control 9-3
9.5	Text on C.R.T. control 9-3
9.6	Cursor control 9-4
9.7	Digital output 9-4
10.	SERVICE INFORMATION 10-1
10.1	Blockdiagram and memory map 10-1
10.2	The multiprocessor system 10-7
10.3	Explanation of signal names 10-9
10.4	Circuit description 10-10
10.5	Description of the diagnostic software 10-25
10.5.1	Introduction 10-25
10.5.2	Softkey selectable diagnostic software 10-25
10.5.3	Hardware selectable diagnostic software 10-27
10.6	Service tools 10-28
10.7	Parts list 10-29

1. INTRODUCTION

This interface is a general purpose bus line interface according to the IEEE-488/IEC-625 and the RS232-C/V24 document by which the oscilloscope can be adapted to make communication possible with other IEEE-/IEC-bus and RS232-C/V24 compatible measuring instruments.

For more detailed information about the bus system refer to the PHILIPS INSTRUMENTATION SYSTEMS REFERENCE MANUAL 9499 997 00411.

For more detailed information about the functioning of the hardware of the interface refer to the SERVICE INFORMATION, chapter 10 of this manual.

1.1 HOW TO USE THIS MANUAL

This handbook has been designed to enable you to use the utmost potential of this option and to answer your questions concerning programming the oscilloscope and how to connect the system to an IEEE controller or to a serial interface.

If you have just received your option, read chapter 2. (INSTALLATION INSTRUCTIONS) before you attempt to operate the instrument. This chapter contains initial installation information and precautions.

Then you can become familiar to the programming of the instrument by reading and following the examples in chapter 8 of the manual.

The best way to feel at ease with the system is to sit down with the programming manual chapter 7 PROGRAMMING CODES, type in the simple driver program (described in section 8.2) and actually key in the commands from chapter 7 or the examples provided in chapter 8.

It won't take long to become familiar with the programming of the oscilloscope and it is well worth the time you invest to obtain a more complete understanding of the "Remote Controlling" of your oscilloscope.

A number of different functions are covered by the term INTERFACE. They cover the most applicable instrumentation interfaces.

Data and communication protocol aspects are slightly described in these chapters.

These descriptions to a large extent are independent of the lower level functions, as these are laid down in the IEC-625 and IEEE-488 standards or by the V24 and RS232-C data communication standards.

2. INSTALLATION INSTRUCTIONS

NOTE: Installation should be carried out by qualified personnel only.

2.1 INITIAL INSPECTION

Check the contents of the shipment for completeness and note whether any damage has occurred during transport. If the contents are incomplete, or there is damage, a claim should be filed with the carrier immediately, and the PHILIPS Sales or Service organisation should be notified in order to facilitate the repair or replacement of the interface.

The following parts should be included in the shipment:

- 1 plug-in printed circuit board.
- 1 IEEE-488 connector, fitted on a small P.C.B.
- 1 RS232-C connector, with a flatcable attached.
- 1 short 10-wire flatcable with connectors.
- 1 long 10-wire flatcable with connectors.
- 1 long 26-wire flatcable with connectors.
- 2 hexagonal nuts with washers.
- 1 Instruction manual.

Check that all jumpers (8 pcs) on the plug-in printed circuit board are positioned as indicated in figure 2.1.

2.2 REMOVING THE INSTRUMENT COVERS

WARNING: The removal of covers is likely to expose live parts, and also accessible terminals may be live. The instrument shall be disconnected from all voltage sources before any installation during which the instrument will be opened.

If afterwards any adjustment, maintenance or repair of the opened instrument under voltage is inevitable, it shall be carried out only by a skilled person who is aware of the hazards involved. Bear in mind that capacitors inside the instrument may still be charged even if the instrument has been separated from all voltage sources.

- Switch the POWER ON-OFF switch to OFF.
- Disconnect the oscilloscope from the mains supply.

The instrument is protected by three covers: a front protection cover, a top cover and a bottom cover. To facilitate the removal of the instrument's covers, first put the front protection cover in position.

Then proceed as follows:

- Hinge the carrying handle clear of the front protection cover.
- Stand the instrument on its protective front cover on a flat surface.
- Unscrew the two screws A and B present in the left foot and the two screws C and D present in the right foot at the rear panel and remove these feet (see figure 2.2).
- The top cover and the bottom cover (without carrying handle) can be removed by shifting them backwards and lifting them off the instrument.

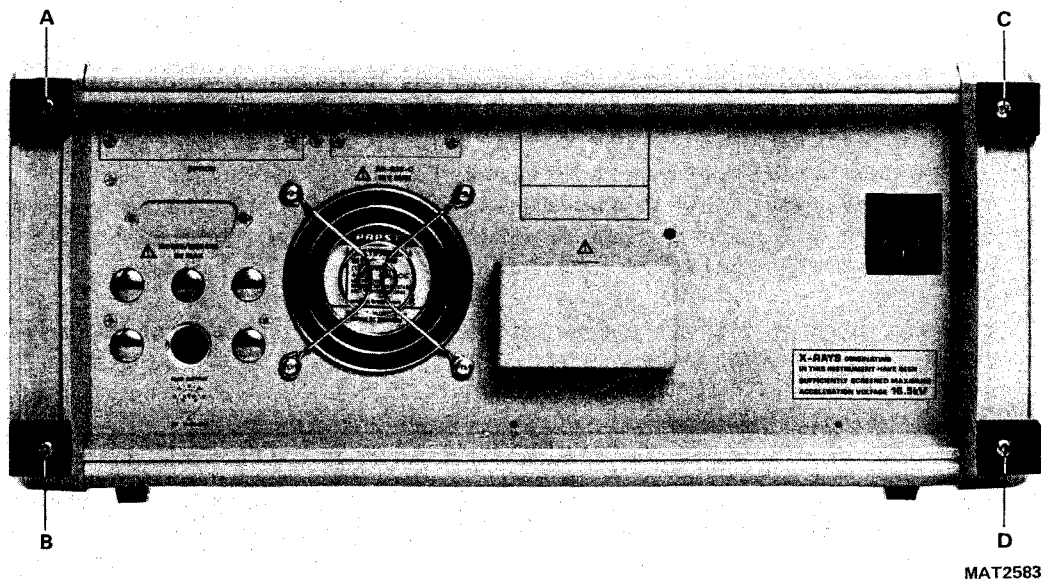

Figure 2.2 Removing the rear feet.

- Place the oscilloscope on a table in horizontal position with the rear panel towards you.

WARNING: Take care of that there are no parts on the table which may damage the printed circuit boards, which are on the bottom side of the instrument.

2.3 INSTALLING THE P.C.B.'s AND THE CABLES

For installation of the printed circuit boards and the cables see also figure 2.3.

Proceed as follows:

- Remove the bracket from the plug-in board rack.
- Install the plug-in printed circuit board in slot A7 or A10.
- Connect the two opposite flatcable connectors of units A6 and A7 or A10 with the short flatcable.

NOTE: The first option to be installed in this instrument must always be placed in the OPTION 1 slot (A7). The OPTION 2 slot (A10) may only be used if an option is installed already in the OPTION 1 slot.

Depending on the selected slot A7 or A10 jumper X723 (on figure 2.1) must be set in the correct position.

- Remove the two coverplates from the holes in the rear panel which are reserved for the IEEE-488 and the RS232-C connectors.
- Remove the two fixation screws of the IEEE-488 connector. The loose metal connector shield should stay on the connector.
- Install the IEEE-488 connector together with the small P.C.B. by shifting it from the inside of the oscilloscope into the hole reserved for this connector.
- Fix the connector together with the small P.C.B. by means of the two fixation screws.
- Install the RS232-C connector together with the flatcable by shifting the flatcable from the outside of the oscilloscope into the hole reserved for this connector.
- Place the washers on the hexagonal nuts and fix the RS232-C connector with them.
- Connect the flat cable to the small P.C.B. at the IEEE-488 connector, according to figure 2.3.
- Install and connect the remaining two long flatcables according to figure 2.3. The cables should be led through the left hole of the transversal partition plate.

NOTE: Care should be taken not to damage the flat cables, while installing them.

- Reinstall the bracket on the plug-in board rack.

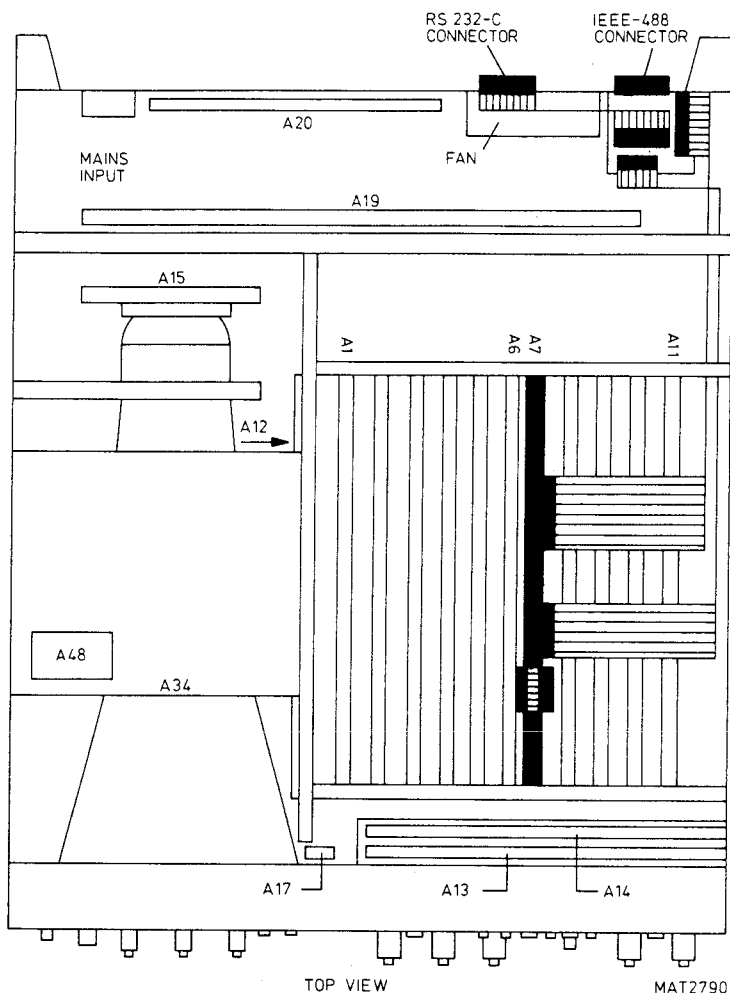

Figure 2.3 Installation of boards and cables.

2.4 INSTALLING THE INSTRUMENT COVERS

- Reinstall the covers by executing the steps mentioned at section 2.2 "REMOVING THE INSTRUMENT COVERS" in the reversed sequence.

NOTE: When reinstalling the top and bottom covers again, take care that the wiring (coaxial cables and flat cables) is not damaged.

- Connect the peripheral equipment (e.g. a controller) to the IEEE-488 or RS232-C connector on the rear panel.
- Reconnect the oscilloscope to the mains supply.
- Turn the instruments on.

2.5 SETTINGS OF THE INTERFACE

Various settings, such as address for IEEE-488 or baud rate for RS232-C, should be done via the softkeys. Therefore, refer to section 3.3 of this manual.

3. OPERATING INSTRUCTIONS INCLUDING REAL TIME CLOCK, DIGITAL PLOT AND USER TEXT

This chapter outlines the procedures and precautions necessary for operating the additional features, provided by this option. It identifies and briefly describes the functions of the front panel controls and indicators, and explains the practical aspects of operation to the operator.

For the use of the explanation structure, please refer to chapter 4.2.1 of the operating manual of the oscilloscope.

3.1 SWITCHING-ON AND POWER UP ROUTINE

3.1.1 Switching on

After the oscilloscope has been connected to the mains (line) voltage in accordance with Section 3.2.1. and 3.2.2. of the operating manual of the oscilloscope it can be switched on with the POWER ON/OFF switch on the front panel. The associated POWER indicator lamp is adjacent to the POWER ON/OFF switch.

Having switched on the oscilloscope, a power-up routine is performed after which the instrument is ready for use.

3.1.2 Power-up routine

When switching on the instrument, note that the internal microprocessor of the oscilloscope automatically starts a test for a number of internal circuits.

If during this test a circuit is found to be faulty, the test stops and this will be indicated as follows:

- The instrument fails to operate normally.
- Some, but not all of the indicator lamps light.

If this occurs, it is recommended to switch off the oscilloscope and switch it on again after a few seconds.

IMPORTANT: If the fault condition persists, contact your local PHILIPS service department.

If the system blocks during operation, it may be due to extremely high static voltages. In this event, an automatic reset of the internal microprocessor system is performed and the operation of the instrument is restored.

3.1.3 Default settings after switching-on

If no back up batteries are installed and the oscilloscope is switched on, an automatic AUTO-SET action is performed.

With back-up batteries installed, the oscilloscope settings at the moment of switching off are restored and the oscilloscope starts up with the same setting.

3.2 ADDITIONAL FEATURES

The option adds the following features to the oscilloscope:

- IEEE-488/IEC-625 interface facility.
- RS232-C/V24 interface facility.
- Real time clock facility.
- User text facility.

The text OPTION>, displayed next to softkey 8 in the main DISPLAY menu, appears at the moment that the oscilloscope knows that an option is installed. Depending on the position of the option in the main-frame of the oscilloscope (slot A7 or A10) the text INTERFACE is displayed in the textfield belonging to softkey 1 or 5 in the DISPLAY OPTION 1 menu.

3.3 EXPLANATION OF OPTIONAL CONTROL AND OPTION MENU STRUCTURE

Option settings can be done via the main DISPLAY menu of the oscilloscope when the text OPTION> is displayed next to softkey 8. Selecting this function by pressing softkey 8, will give the main option menu DISPLAY OPTION 1.

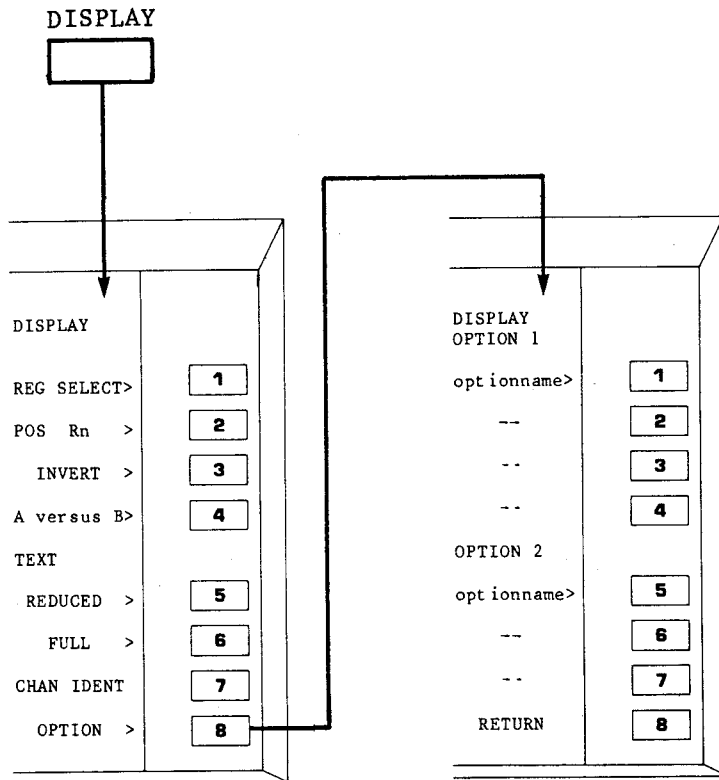

Figure 3.1 Main option menu DISPLAY OPTION 1.

In case this option is installed, and it is the only one in the oscilloscope, the option name for OPTION 1 will be INTERFACE and the option name for OPTION 2 will not be displayed.

Note that options always are installed, starting from slot A7 in the main frame (see chapter 2 INSTALLATION).

The next page gives an overview of the menu structure behind the OPTION> softkey.

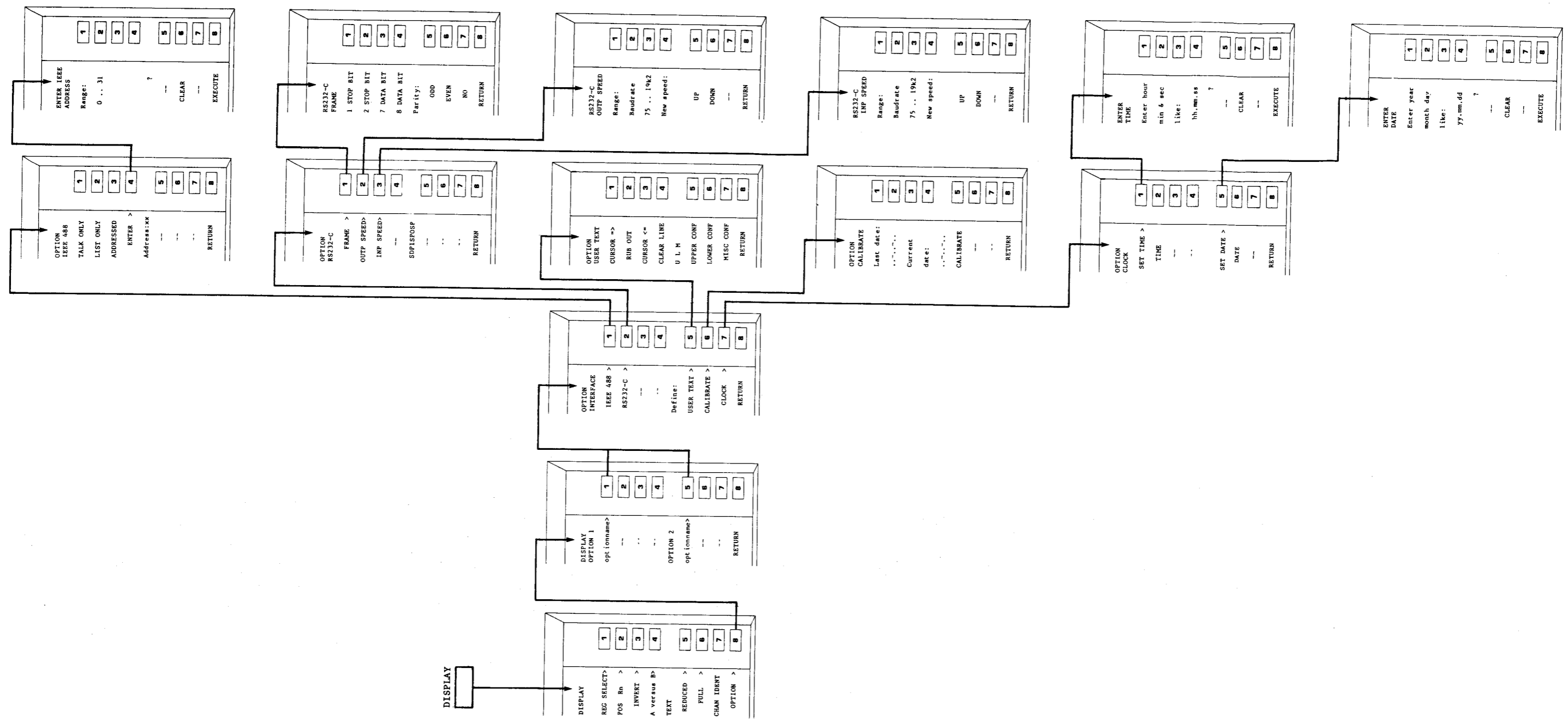
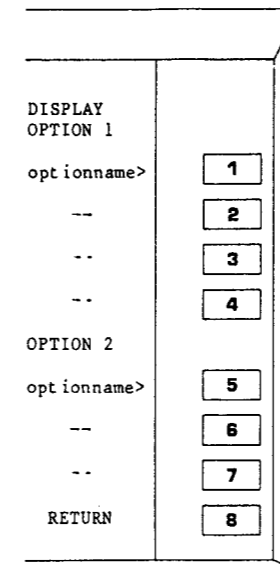

Figure 3.2 Menu structure behind the OPTION softkey.



After pressing the softkey OPTION in the main DISPLAY menu, menu DISPLAY OPTION 1 is displayed and the possible options can be selected.

1 Optionname> (name of the installed option in slot A7)

With this softkey the option functions can be selected for the option in slot A7.

2 --

3 --

4 --

5 Optionname> (name of the installed option in slot A10)

With this softkey the option functions can be selected for the option in slot A10.

SINCE THIS MANUAL DEALS WITH THE OPTION PM8956A ONLY INTERFACE FUNCTIONS ARE DISCUSSED.

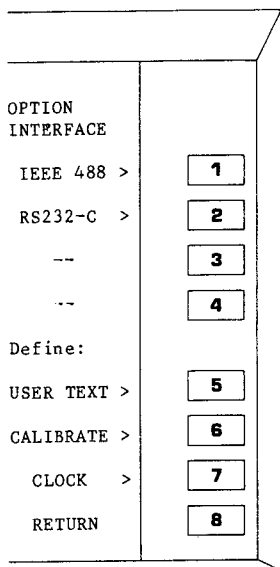

If INTERFACE is selected in menu DISPLAY OPTION 1, the OPTION INTERFACE menu is displayed and all the features provided by the option can be activated. The softkey text lines and the softkeys of the oscilloscope are switched to the option. The lowest line of the trace area will now show the current date and time (of the real time clock).

1/5 1 IEEE 488>

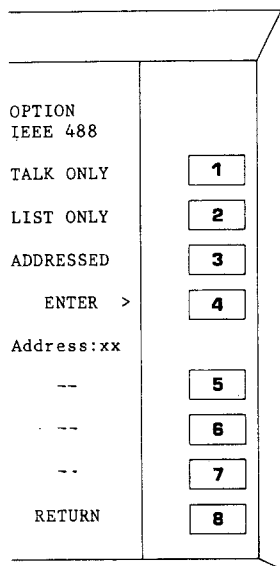

Selecting IEEE 488> leads to another menu: OPTION IEEE 488, where the interface parameters for IEEE communication can be defined.

1/5 1 1 TALK ONLY

Pressing the softkey TALK ONLY defines the oscilloscope to act as a talker on the bus system. This is indicated by an intensified text TALK ONLY (note that there can only be one talker on the bus system at a given time).

1/5 1 2 LIST ONLY

Pressing the softkey LIST ONLY defines the oscilloscope to act as a listener on the bus system. This is indicated by an intensified text LIST ONLY.

1/5 1 3 ADDRESSED

Pressing the softkey ADDRESSED, defines the oscilloscope to act as a talker as well as a listener indicated by an intensified text ADDRESSED.

NOTE: The text ENTER and Address:xx is only visible if the function ADDRESSED is selected.

1/5 1 4 ENTER>

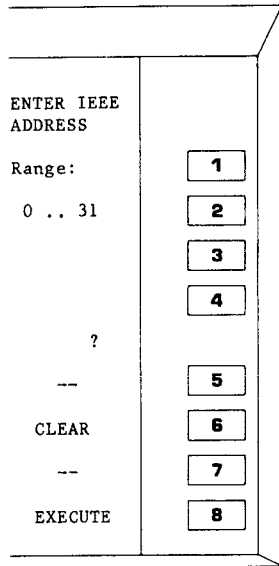

Pressing this softkey selects the ENTER IEEE ADDRESS. Now a new address can be entered by using the numeric keyboard on the front panel of the oscilloscope. Any address between 0 and 31 can be entered and will be displayed in the textline with ? and in the textline Address:xx in the OPTION IEEE 488 menu.

1/5 1 4 1 --

1/5 1 4 2 --

1/5 1 4 3 --

1/5 1 4 4 --

1/5 1 4 5 --

1/5 1 4 6 CLEAR

This function clears the already entered address, which is displayed in the textfield ?.

1/5 1 4 7 --

1/5 1 4 8 EXECUTE

Pressing this softkey stores the entered IEEE address and returns the system to the OPTION IEEE488 menu. If EXECUTE is pressed after CLEAR, the previously programmed value remains.

1/5 1 5 --

1/5 1 6 --

1/5 1 7 --
 1/5 1 8 RETURN

Returns the system to the menu OPTION INTERFACE.

1/5 2 RS232-C>

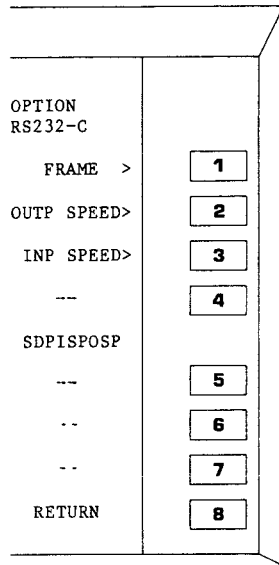

Selecting RS232-C> leads to another menu: OPTION RS232-C, where interface parameters for serial communication can be defined.

1/5 2 1 FRAME>

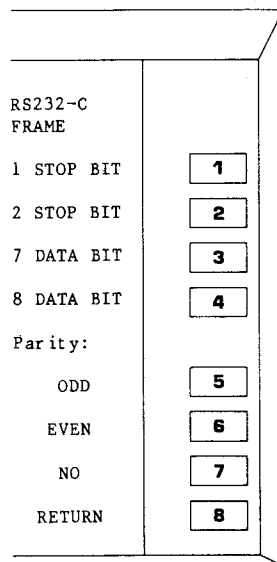

Pressing the softkey FRAME selects the RS232-C FRAME menu where the serial communication parameters like the number of stop bits, the number of data bits and the parity can be defined.

1/5 2 1 1 1 STOP BIT

Defines 1 STOP bit in the data frame indicated by an intensified text 1 STOP BIT.

1/5 2 1 2 2 STOP BIT

Defines 2 STOP bits in the data frame indicated by an intensified text 2 STOP BIT.

- 1/5 2 1 3 7 DATA BIT
 Defines 7 DATA bits in the data frame indicated by an intensified text 7 DATA BIT.
- 1/5 2 1 4 8 DATA BIT
 Defines 8 DATA bits in the data frame indicated by an intensified text 8 DATA BIT.
- 1/5 2 1 5 ODD
 Defines an odd parity (this means an odd number of "ones" in the data part of the frame) indicated by an intensified text ODD.
- 1/5 2 1 6 EVEN
 Defines an even parity (this means an even number of "ones" in the data part of the frame) indicated by an intensified text EVEN.
- 1/5 2 1 7 NO
 Defines NO parity indicated by an intensified text NO.
- 1/5 2 1 8 RETURN
 Pressing this softkey will store the entered frame format and the system returns to the previous menu OPTION RS232-C.
- 1/5 2 2 OUTP SPEED>

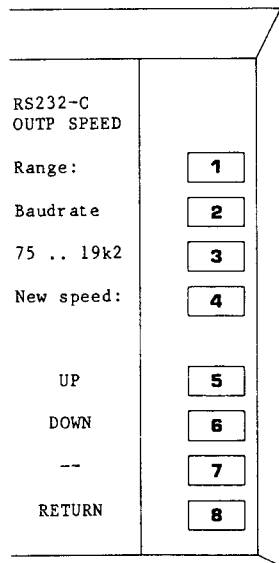

After selecting OUTP SPEED>, the output baudrate of the serial interface can be defined.
 The available range for baudrates is:
 75, 110, 150, 300, 600, 1200, 2400, 4800, 9600 and 19200 baud.
 The actual output speed is displayed in the textfield ?.

- 1/5 2 2 1 --
- 1/5 2 2 2 --

1/5 2 2 3 --
 1/5 2 2 4 --
 1/5 2 2 5 UP

Pressing this softkey will increase the actual baudrate with one step in the range until the maximum baudrate of 19200 baud is reached.

1/5 2 2 6 DOWN

Pressing this softkey will decrease the actual baudrate with one step in the range until the minimum baudrate of 75 baud is reached.

1/5 2 2 7 --

1/5 2 2 8 RETURN

Pressing this softkey, returns the system to the previous menu OPTION RS232-C.

1/5 2 3 INP SPEED>

RS232-C INP SPEED	
Range:	<input type="text" value="1"/>
Baudrate	<input type="text" value="2"/>
75 .. 19k2	<input type="text" value="3"/>
New speed:	<input type="text" value="4"/>
UP	<input type="text" value="5"/>
DOWN	<input type="text" value="6"/>
--	<input type="text" value="7"/>
RETURN	<input type="text" value="8"/>

The input baudrate of the serial interface can be defined.
 The available range for baudrates is:
 75, 110, 150, 300, 600, 1200, 2400, 4800, 9600 and 19200 baud.

The actual input speed is displayed in the textfield ?.

1/5 2 3 1 --
 1/5 2 3 2 --
 1/5 2 3 3 --
 1/5 2 3 4 --
 1/5 2 3 5 UP

Pressing this softkey will increase the actual input speed with one step in the range until the maximum baudrate of 19200 baud is reached.

1/5 2 3 6 DOWN

Pressing this softkey will decrease the actual input speed with one step in the range until the minimum baudrate of 75 baud is reached.

1/5 2 3 7 --

1/5 2 3 8 RETURN

Pressing this softkey, returns the system to the previous menu OPTION RS232-C.

NOTE: The textline SDPISPOSP, displayed in the menu OPTION RS232-C stands for Stop bits, Data bits, Parity, Input SPEED and Output SPEED (see also section 5.4).

28E1K2075 means:

2 Stop bits, 8 Data bits, Even Parity, 1200 baud input speed and 75 baud output speed.

1/5 2 4 --

1/5 2 5 --

1/5 2 6 --

1/5 2 7 --

1/5 2 8 RETURN

Pressing this softkey returns the system to the previous menu OPTION INTERFACE.

1/5 3 --

1/5 4 --

1/5 5 USER TEXT>

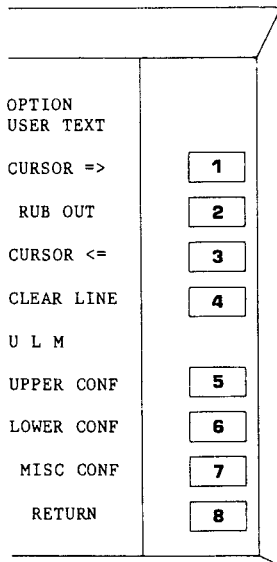

With function USER TEXT it is possible to define a text of 80 characters. This text will be displayed on the bottom text area of the C.R.T. screen, and is only visible if the USER TEXT menu is activated.

The user text can be read by the interfaces. The user text line is split up in two parts of 40 characters on the bottom text area of the C.R.T. screen. The actual cursor position is indicated with an _.

When the cursor moves over already existing text, the cursor position is indicated by an intensified character in the text line. There are three character types available to select.

U (Upper case characters)

The actual available upper case character is displayed in the softkey text field "U".

To select another uppercase character press the AMPL/DIV UP/DOWN control of channel A, on the front panel of the oscilloscope. Pressing the left side of the UP/DOWN control decreases the alphabetic order (A...Z). Pressing the right side increases the order. There is an automatic wrap around from Z -> A and from A -> Z.

L (Lower case characters)

The actual available lower case character is displayed in the softkey textfield "L".

To select another lower case character press the AMPL/DIV UP/DOWN control of channel B on the front panel of the oscilloscope. Pressing the left side of the UP/DOWN control decreases the alphabetic order (a...z). Pressing the right side increases the order. There is an automatic wrap around from z -> a and from a -> z.

M (Miscellaneous characters)

The actual available miscellaneous character is displayed in the softkey textfield "M".

To select another miscellaneous character press the TIME/DIV UP/DOWN control on the front panel of the oscilloscope.

The following characters are available:

0	1	2	3	4	5	6	7	8	9
:	;	<	=	>	?	@	[]
^		`	{		}		!	"	#
\$	%	&	'	()	*	+	,	-
.	/								

Pressing the left side of the TIME/DIV UP/DOWN control decreases the position in the range showed above, pressing the right side increases the order.

There is a wrap around from / to Ø and Ø to /.

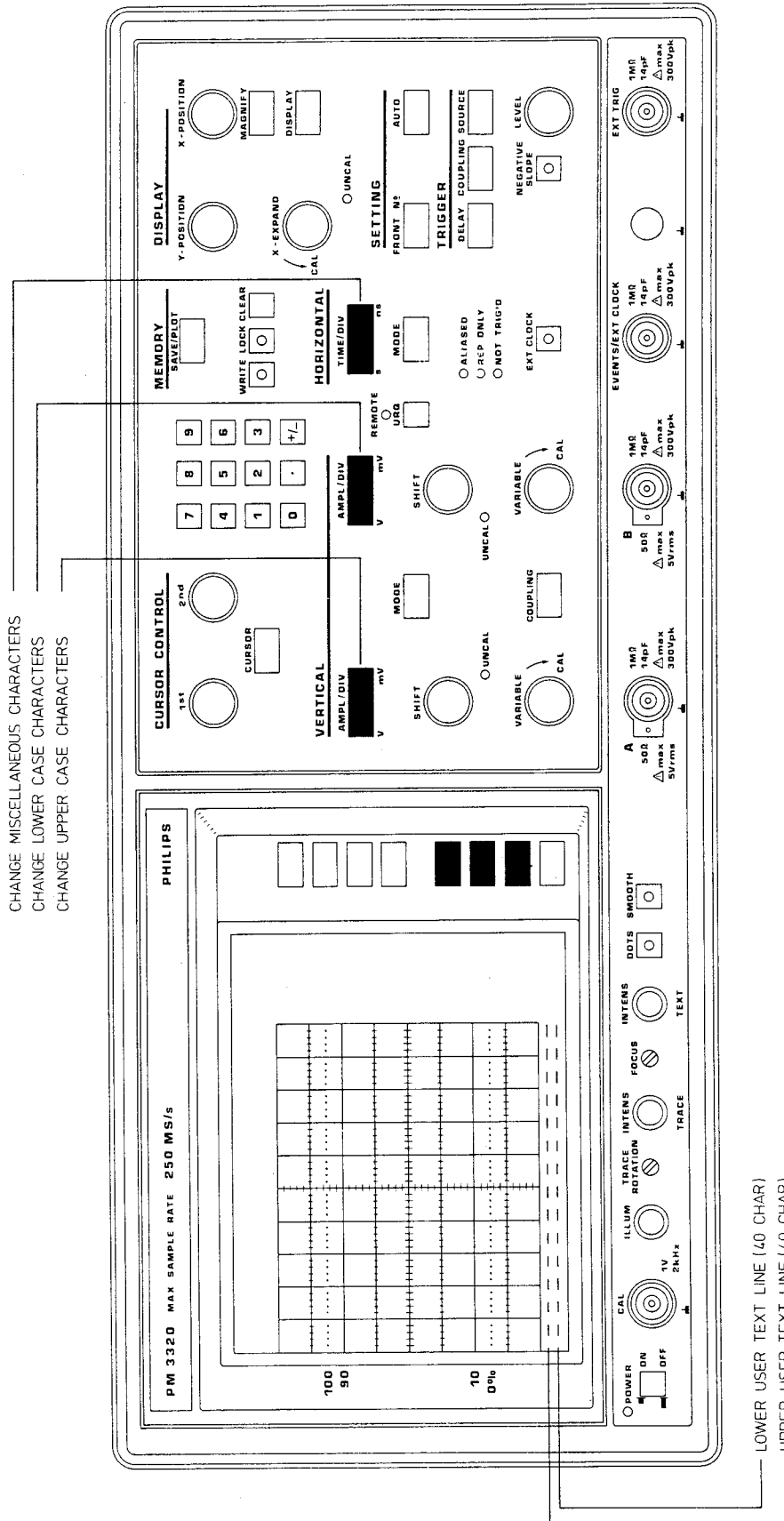

CHANGE MISCELLANEOUS CHARACTERS
 CHANGE LOWER CASE CHARACTERS
 CHANGE UPPER CASE CHARACTERS

LOWER USER TEXT LINE (40 CHAR)
 UPPER USER TEXT LINE (40 CHAR)

Figure 3.3 User text (also applicable for PM3340).

- 1/5 5 1 CURSOR =>
- Every time the CURSOR => softkey is pressed, the cursor position advances with one step in the user text lines until the last position is reached (position 40 in the second text line).
- 1/5 5 2 RUB OUT
- The previously entered character is rubbed out. The cursor moves one position backwards.
- 1/5 5 3 CURSOR <=
- Every time the CURSOR <= softkey is pressed, the cursor position is moved to the left with one step until the first position is reached. (position 0 in the first text line).
- 1/5 5 4 CLEAR LINE
- The totally entered text will be cleared when pressing this key. So all 80 characters.
- 1/5 5 5 UPPER CONF
- Pressing this key stores the character, represented at that moment on the position "U" in the textline at the current cursor position on the C.R.T. screen (uppercase character).
- 1/5 5 6 LOWER CONF
- Pressing this key stores the character, represented at that moment on the position "L" in the textline at the current cursor position on the C.R.T. screen (lowercase character).
- 1/5 5 7 MISC CONF
- Pressing this key stores the character, represented at that moment on the position "M" in the textline at the current cursor position on the C.R.T. screen.
- 1/5 5 8 RETURN
- Returns the system to the previous menu OPTION INTERFACE.
- NOTE: When pressing the CONFirm function (U, L or M) the cursor advances one position.

1/5 6 CALIBRATE>

OPTION	
CALIBRATE	
Last date:	<input type="text" value="1"/>
.....	<input type="text" value="2"/>
Current	<input type="text" value="3"/>
date:	<input type="text" value="4"/>
.....	
CALIBRATE	<input type="text" value="5"/>
--	<input type="text" value="6"/>
--	<input type="text" value="7"/>
RETURN	<input type="text" value="8"/>

The function CALIBRATE offers the possibility to write the calibration date into the back-up memory of the oscilloscope, indicating the last calibration and/or service date.

- 1/5 6 1 --
- 1/5 6 2 --
- 1/5 6 3 --
- 1/5 6 4 --
- 1/5 6 5 CALIBRATE

Pressing this key enters the current date in the memory. The last stored date will be changed into the current date.

- 1/5 6 6 --
- 1/5 6 7 --
- 1/5 6 8 RETURN

Returns the system to the previous menu OPTION INTERFACE.

1/5 7 CLOCK>

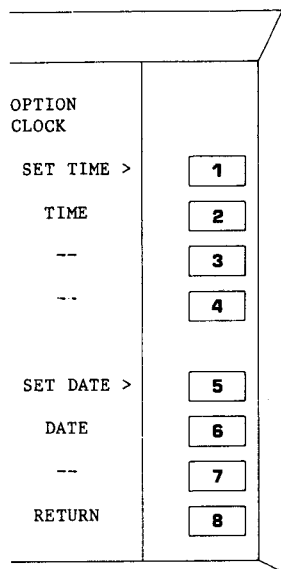

With the CLOCK function it is possible to set the date and the time of the real time clock via the OPTION CLOCK menu.

The display of the TIME and the DATE is a part of the display of register R3 and can be shifted over the screen, using the Y-POSITION control.

1/5 7 1 SET TIME>

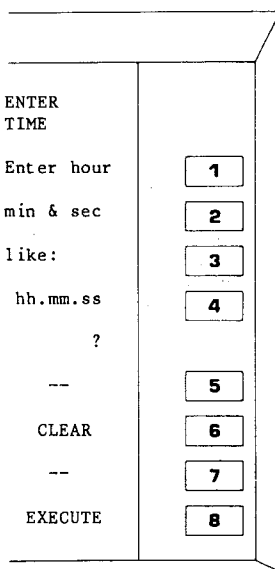

Pressing the softkey SET TIME> results in the ENTER TIME menu. It is now possible to enter the time via the key board on the front.

Enter: hours hh
 . .
 minutes mm
 . .
 seconds ss

- 1/5 7 1 1 --
- 1/5 7 1 2 --
- 1/5 7 1 3 --
- 1/5 7 1 4 --
- 1/5 7 1 5 --
- 1/5 7 1 6 CLEAR

The already entered time setting is cleared when this softkey is pressed.

1/5 7 1 7 --

1/5 7 1 8 RETURN

Pressing this softkey stores the entered time and returns the system to the previous menu OPTION CLOCK.

1/5 7 2 TIME

This softkey defines the display of the TIME on the screen (ON/OFF), indicated by an intensified text TIME. TIME is a toggle function: the TIME is displayed in the lower right corner of the C.R.T. screen, even if no OPTION MENU is selected.

1/5 7 3 --

1/5 7 4 --

1/5 7 5 SET DATE>

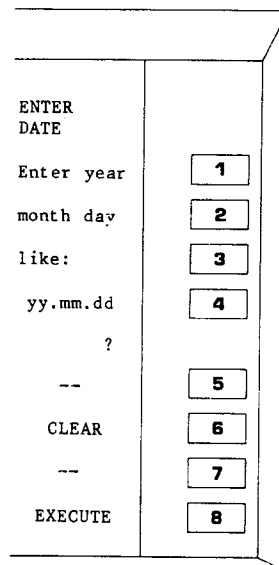

Pressing the softkey SET DATE> results in the ENTER DATE menu. Now it is possible to enter the date via the keyboard on the front.

Enter: year yy
 . .
 month mm
 . .
 day dd

Leap year correction is implemented.

1/5 7 5 1 --

1/5 7 5 2 --

1/5 7 5 3 --

1/5 7 5 4 --

1/5 7 5 5 --

1/5 7 5 6 CLEAR

The already entered date setting is cleared when this softkey is pressed

1/5 7 5 7 --

1/5 7 5 8 EXECUTE

Pressing this softkey stores the entered date and returns the system to the previous menu OPTION CLOCK.

1/5 7 6 DATE

This softkey defines the display of the DATE on the screen (ON/OFF), indicated by an intensified text DATE. DATE is a toggle-function. The DATE is displayed in the lower right corner of the C.R.T. screen, even if no OPTION menu is selected.

1/5 7 7 --

1/5 7 8 RETURN

Returns the system to the OPTION INTERFACE menu.

1/5 8 RETURN

Returns the system to the DISPLAY OPTION 1 menu.

6 --

7 --

8 RETURN

Returns the system to the main DISPLAY menu of the oscilloscope.

3.4 DIGITAL PLOT AND PRINT MODES

The oscilloscope functions are now extended with DIGITAL PLOT and DIGITAL PRINT modes like the REGISTER PLOT, the REGISTER PRINT, the REGISTER AUTO PLOT, the REGISTER AUTO PRINT, the SCREEN PLOT and the SCREEN PRINT mode.

REGISTER PLOT and REGISTER PRINT stands for direct plotting or printing of register contents without the influence of display functions like for example Y-POS, Y-MAGNIFY, X-POS, X-EXPAND, X-MAGNIFY, INVERT or DOTS.

SCREEN PLOT and SCREEN PRINT stands for plotting or printing of register contents including the influence of the above mentioned display functions.

NOTE: 1) To assure a good plotter/printer-oscilloscope initialisation for the serial interface, first switch on the plotter/printer and then the oscilloscope. Also use this way of initialisation when you change the plotter language. (HPGL - PHILIPS and vice versa).

2) When for some reason the interface initialisation went wrong, and the interface is blocked, a message

DIGITAL output activated,
but no output on selected interface

is displayed on the screen of the oscilloscope.

In this case:

- Re-initialise the oscilloscope (switch off/on).
- Check the cable connections to your plotter.
- Check the interface parameter settings via the OPTION INTERFACE menu.
- Check the plotter or printer interface selection via the DIGITAL SELECT menu.

3.4.1 Digital plot specification

3.4.1.1 REGISTER PLOT mode (via the SAVE/PLOT menu)

1: Plotter pens:

Pen 1 is used for the data and text of channel A.

Pen 2 is used for the data and text of channel B.

Pen 3 is used for texts which are not related to channel A or to channel B.

Pen 4 is not used.

Pen 5 is used for the graticule, the time and the date.

2: Time and date:

The time and the date are plotted above the upper right corner of the graticule.

3: Text:

The FULL text of the selected register is always plotted and is placed below the lowest graticule line. Settings like CHANNEL IDENT, A versus B and INVERT (selected via the DISPLAY menu) are taken into account during the plot.

4: Plot size:

The data plot area is 10 div. (H) x 10 div. (W).

The plot size (including text) can be changed (via menu PLOTTER SETUP) with a multiplication factor.

With a factor of 1, each division is 1 cm (H) x 1 cm (W).

This factor has a range of 0.5 to 2.0 with a resolution of 0.1. The default Y-POS, Y-MAGNIFY, X-POS, X-EXPAND and X-MAGNIFY are taken into account on the plot-out.

5: Quadrant:

The plot quadrant on the plot medium can be selected via the menu PLOTTER SETUP.

6: Grid:

The grid to be plotted can be selected via the menu PLOTTER SETUP.

7: Plot output direction:

The plot output can be directed (via menu PLOTTER SETUP) to either the IEEE interface (which is set automatically to TALK ONLY during the plot time) or the RS232-C interface.

8: Signal processing:

The signal to be plotted, can be processed before plotting, to increase the plot speed. This means that vertical changes in the signal of about 5 bit will not result in a real plot action. Only if a dot is out of this range, a line is plotted (starting at the last plotted dot) to just before this point, after which the signal processing algorithm starts again. This may introduce some distortion. Signal processing is carried out if SMOOTH (PM3320A) or AVERAGE C=4 (PM3340) is selected. Signal processing is not possible if A versus B is selected.

9: Dots plot:

Only dots, without dot join, can be plotted. Between every two dots a pen-up and pen-down is given. This plot mode is carried out if DOTS is turned on.

This mode is recommended for eye-patterns.

3.4.1.2 REGISTER AUTO PLOT mode (via the SAVE/PLOT menu, only if SINGLE shot mode is selected)

1: Plotter pens:

Pen 1 is used for the data and text of channel A.
Pen 2 is used for the data and text of channel B.
Pen 3 is used for texts which are not related to channel A or to channel B.
Pen 4 is not used.
Pen 5 is used for the graticule, the time and the date.

2: Time and date:

The time and the date are plotted above the upper right corner of the graticule.

3: Text:

The plotting of FULL text depends on whether the FULL text is selected for display on the C.R.T. screen or not.
FULL text is placed below the lowest graticule line.
Settings like CHANNEL IDENT, A versus B and INVERT (selected via the DISPLAY menu) are taken into account during the plot.

4: Plot size:

The data plot area is 10 div. (H) x 10 div. (W).

The plot size (including text) can be changed (via menu PLOTTER SETUP) with a multiplication factor.
With a factor of 1, each division is 1 cm (H) x 1 cm (W).
This factor has a range of 0.5 to 2.0 with a resolution of 0.1.
The default Y-POS, Y-MAGNIFY, X-POS, X-EXPAND and X-MAGNIFY are taken into account on the plot-out.

5: Quadrant:

The plot quadrant on the plot medium can be selected via the menu PLOTTER SETUP.

6: Grid:

The grid to be plotted can be selected via the menu PLOTTER SETUP.

7: Plot output direction:

The plot output can be directed (via menu PLOTTER SETUP) to either the IEEE interface (which is set automatically to TALK ONLY during the plot time) or the RS232-C interface.

8: Signal processing:

The signal to be plotted, can be processed before plotting, to increase the plot speed. This means that vertical changes in the signal of about 5 bit will not result in a real plot action. Only if a dot is out of this range, a line is plotted (starting at the last plotted dot) to just before this point, after which the signal processing algorithm starts again. This may introduce some distortion. Signal processing is carried out if SMOOTH (PM3320A) or AVERAGE C=4 (PM3340) is selected, Signal processing is not possible if A versus B is selected.

9: Dots plot:

Only dots, without dot join, can be plotted. Between every two dots a pen-up and pen-down is given. This plot mode is carried out if DOTS is turned on.

This mode is recommended for eye-patterns.

3.4.1.3 SCREEN PLOT mode (via the DISPLAY menu)1: Plotter pens:

Pen 1 is used for the data and text of register R0.
 Pen 2 is used for the data and text of register R1.
 Pen 3 is used for the data and text of register R2.
 Pen 4 is used for the data and text of register R3.
 Pen 5 is used for the graticule, the time and the date.

2: Time and date:

The time and the date are plotted above the upper right corner of the graticule.

3: Text:

The plotting of FULL and/or REDUCED text depends on whether the FULL and/or REDUCED text is selected for display on the C.R.T. screen or not.

4: Plot size:

The data plot area is 8 div. (H) x 10 div. (W).

The plot size (including text) can be changed (via menu PLOTTER SETUP) with a multiplication factor.

With a factor of 1, each division is 1 cm (H) x 1 cm (W).

This factor has a range of 0.5 to 2.0 with a resolution of 0.1.

5: Quadrant:

The plot quadrant on the plot medium can be selected via the menu PLOTTER SETUP.

6: Grid:

The grid to be plotted can be selected via the menu PLOTTER SETUP.

7: Plot output direction:

The plot output can be directed (via menu PLOTTER SETUP) to either the IEEE interface (which is set automatically to TALK ONLY during the plot time) or the RS232-C interface.

8: Signal processing:

The signal to be plotted, can be processed before plotting, to increase the plot speed. This means that vertical changes in the signal of about 5 bit will not result in a real plot action. Only if a dot is out of this range, a line is plotted (starting at the last plotted dot) to just before this point, after which the signal processing algorithm starts again. This may introduce some distortion. Signal processing is carried out if SMOOTH (PM3320A) or AVERAGE C=4 (PM3340) is selected. Signal processing is not possible if A versus B is selected.

9: Dots plot:

Only dots, without dot join, can be plotted. Between every two dots a pen-up and pen-down is given. This plot mode is carried out if DOTS is turned on.
This mode is recommended for eye-patterns.

3.4.2 Digital print specification3.4.2.1 REGISTER PRINT mode (via the SAVE/PLOT menu)1: Time and date:

The time and the date are printed above the upper right corner of the graticule.

2: Text:

The FULL text of the selected register is always printed and is placed below the lowest graticule line.
Settings like CHANNEL IDENT, A versus B and INVERT (selected via the DISPLAY menu) are taken into account during the print.

3: Print size:

The data print area is 10 div. (H) x 10 div. (W), which corresponds to 10 x 10 cm approx. This size cannot be changed.

4: Grid:

The grid to be printed can be selected via the menu PRINTER SETUP.

5: Print output direction:

The print output can be directed (via menu PRINTER SETUP) to either the IEEE interface (which is set automatically to TALK ONLY during the print time) or the RS232-C interface.

6: Dots print:

Only dots, without dot join, can be printed. This print mode is carried out if DOTS is turned on.
This mode is recommended for eye-patterns.

3.4.2.2 REGISTER AUTO PRINT mode (via the SAVE/PLOT menu, only if SINGLE shot mode is selected)1: Time and date:

The time and the date are printed above the upper right corner of the graticule.

2: Text:

The FULL text of the selected register is always printed and is placed below the lowest graticule line.
Settings like CHANNEL IDENT, A versus B and INVERT (selected via the DISPLAY menu) are taken into account during the print.

3: Print size:

The data print area is 10 div. (H) x 10 div. (W), which corresponds to 10 x 10 cm approx. This size cannot be changed.

4: Grid:

The printed grid type can be selected via the menu PRINTER SETUP.

5: Print output direction:

The print output can be directed (via menu PRINTER SETUP) to either the IEEE interface (which is set automatically to TALK ONLY during the print time) or the RS232-C interface.

6: Dots print:

Only dots, without dot join, can be printed. This print mode is carried out if DOTS is turned on.
This mode is recommended for eye-patterns.

3.4.2.3 SCREEN PRINT mode (via the DISPLAY menu)1: Time and date:

The time and the date are printed above the upper right corner of the graticule.

2: Text:

The printing of FULL and/or REDUCED text depends on whether the FULL and/or REDUCED text is selected for display on the C.R.T. screen or not.

3: Print size:

The data print area is 8 div. (H) x 10 div. (W), which corresponds to 8 x 10 cm approx. This size cannot be changed.

4: Grid:

The grid to be printed can be selected via the menu PRINTER SETUP.

5: Print output direction:

The print output can be directed (via menu PRINTER SETUP) to either the IEEE interface (which is set automatically to TALK ONLY during the print time) or the RS232-C interface.

6: Dots print:

Only dots, without dot join, can be printed. This print mode is carried out if DOTS is turned on. This mode is recommended for eye-patterns.

3.4.3 Digital plot and print menus

3.4.3.1 DIGITAL SELECT menu (see figure 3.4)

This menu can be selected via the SAVE/PLOT menu of the oscilloscope.

Via this menu tree it is possible to select the required plotter or printer, plot or print direction and plot size.

- Press pushbutton SAVE/PLOT, this results in the display of the SAVE/PLOT menu.

8 SELECT>

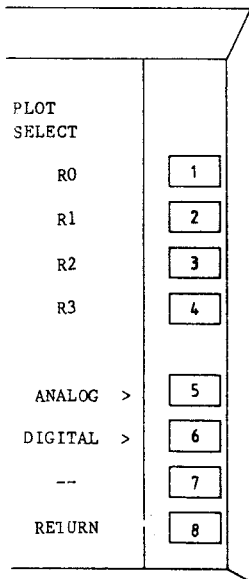

If SELECT is selected, the PLOT SELECT menu, which now is extended with the function DIGITAL>, is displayed. DIGITAL> can now be selected after which a number of digital plot or print settings can be done.

ANALOG> as described in the operating manual of the oscilloscope, remains possible.

8 6 DIGITAL>

DIGITAL SELECT	
PLOTTERS >	1
PRINTERS >	2
--	3
--	4
PLOT PRINT	5
--	6
--	7
RETURN	8

If DIGITAL is selected, the DIGITAL SELECT menu is displayed and the plotter or printer type to be used can be selected.

8 6 1 PLOTTERS>

DIGITAL PLOTTERS	
PM8153/1 >	1
PM8153/6 >	2
PM8154 >	3
PM8155 >	4
HP7475A >	5
HP7550 >	6
--	7
RETURN	8

The DIGITAL PLOTTERS menu is displayed and different plotter types can now be selected.

8	6	1	1	PM8153/1	
8	6	1	2	PM8153/6	
8	6	1	3	PM8154	(only PHILIPS language, no HPGL)
8	6	1	4	PM8155	(use HPGL only)
8	6	1	5	HP7475A	
8	6	1	6	HP7550	

8 6 1 1-6

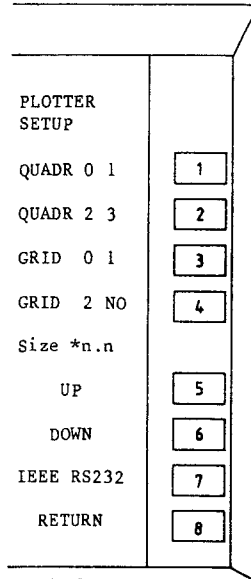

After pushing one of the six plotter select softkeys in the DIGITAL PLOTTERS menu, the PLOTTER SETUP menu is displayed.

8 6 1 1-6 1 QUADR 0 1
 8 6 1 1-6 2 QUADR 2 3

A selection can be made of one out of four plot quadrants on the plotter medium. The selected quadrant is displayed intensified.

8 6 1 1-6 3 GRID 0 1
 8 6 1 1-6 4 GRID 2 NO

A selection can be made between three grid types or NO grid. Grid 0 is a complete grid, consisting of border lines and vertical and horizontal grid lines. Grid 1 is a grid of border lines and centre vertical and horizontal grid lines. Grid 2 is a grid of only border lines. The selected grid type is displayed intensified.

8 6 1 1-6 5 UP

The actual plot size factor is displayed in the softkey text area on the screen. The plot size factor can be increased from factor 0.5 up to 2 in steps of 0.1 by operating the UP pushbutton.

8 6 1 1-6 6 DOWN

The actual plot size factor is displayed in the softkey text area on the screen. The plot size factor can be decreased from factor 2 up to 0.5 in steps of 0.1 by operating the DOWN pushbutton.

8 6 1 1-6 7 IEEE RS232

A selection can be made between the IEEE and the RS232 interface as digital plotter output interface. The interface parameters for serial plotting have to be set accordingly via the OPTION INTERFACE menu.

8 6 1 1-6 8 RETURN

After pushing softkey RETURN, the DIGITAL PLOTTERS menu is displayed again.

8 6 1 7 --

8 6 1 8 RETURN

After pushing softkey RETURN, the DIGITAL SELECT menu is displayed again.

8 6 2 PRINTERS>

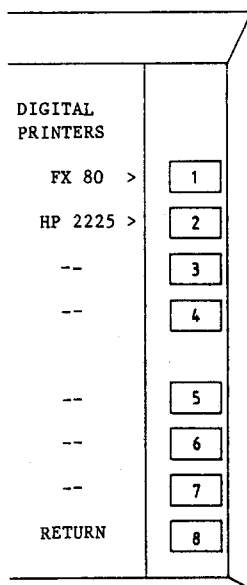

The DIGITAL PRINTERS menu is displayed and different printer types can now be selected.

8 6 2 1 FX 80

8 6 2 2 HP 2225

NOTE : For the FX80 printer are several IEEE interfaces available. Only the interface type 8165 has the capability for the LISTEN ONLY mode. Therefore only FX80 printers, equipped with the 8165 interface, can be used with this oscilloscope.

8 6 2 1-2

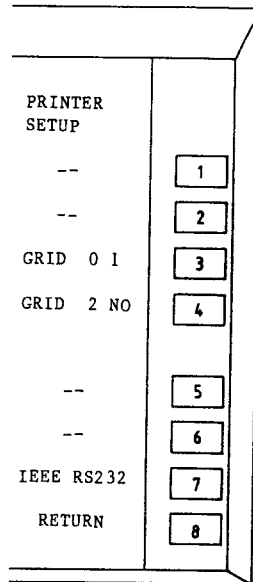

After pushing one of the two printer select softkeys in the DIGITAL PRINTERS menu, the PRINTER SETUP menu is displayed.

8 6 2 1-2 1 --
 8 6 2 1-2 2 --
 8 6 2 1-2 3 GRID 0 1
 8 6 2 1-2 4 GRID 2 NO

A selection can be made between three grid types or NO grid.
 Grid 0 is a complete grid, consisting of border lines and vertical and horizontal grid lines.
 Grid 1 is a grid of border lines and centre vertical and horizontal grid lines.
 Grid 2 is a grid of only border lines.
 The selected grid type is displayed intensified.

8 6 2 1-2 5 --
 8 6 2 1-2 6 --
 8 6 2 1-2 7 IEEE RS232

A selection can be made between the IEEE and the RS232 interface as digital printer output interface. The interface parameters for serial printing have to be set accordingly via the OPTION INTERFACE menu.

8 6 2 1-2 8 RETURN

After pushing softkey RETURN, the DIGITAL PRINTERS menu is displayed again.

8 6 2 3 --
 8 6 2 4 --

8	6	2	5	--
8	6	2	6	--
8	6	2	7	--
8	6	2	8	RETURN

After pushing softkey RETURN, the DIGITAL SELECT menu is displayed again.

8	6	3	--
8	6	4	--
8	6	5	PLOT PRINT

A selection can be made between plotting or printing. This selection also determines if in the actual plot/print menus PLOT or PRINT appears. The selected option is displayed intensified.

8	6	6	--
8	6	7	--
8	6	8	RETURN

After pushing softkey RETURN, the PLOT SELECT menu is displayed again.

8	7	--
8	8	RETURN

After pushing softkey RETURN, the SAVE/PLOT menu is displayed again.

3.4.3.2 PLOT DIGITAL menu (see figure 3.4)

The REGISTER PLOT function can be selected via the SAVE/PLOT menu, if PLOT was selected before in the DIGITAL SELECT menu:

- Press pushbutton SAVE/PLOT, this results in the display of the SAVE/PLOT menu, which now is extended with the function DIGITAL>.

ANALOG> as described in the operating manual of the oscilloscope, is still possible.

6 DIGITAL>

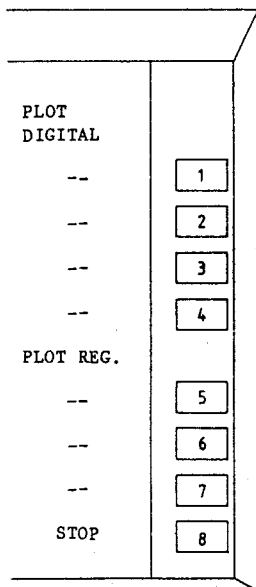

If DIGITAL is selected, the contents of the selected register is transferred to the digital plot output. The default register is R0. Other registers to plot as well as the plotter type, the plot size, the plot quadrant, the grid type and the plotter interface can be selected via the SELECT function of the SAVE/PLOT menu. During the PLOT action, the PLOT DIGITAL menu is displayed and a message

***** PLOTTER ACTIVE *****
Changes are possible after plotter has stopped.

is displayed.

At the end of the DIGITAL REGISTER PLOT action, the menu SAVE/PLOT is displayed again.

- 6 1 --
- 6 2 --
- 6 3 --
- 6 4 --
- 6 5 --
- 6 6 --
- 6 7 --
- 6 8 STOP

A PLOT action can be interrupted by pushing softkey STOP. The SAVE/PLOT menu is then displayed again. During a plot action, it is not possible to switch to another softkey menu or to change any other function of the oscilloscope.

3.4.3.3 AUTO PLOT DIGITAL menu (see figure 3.4)

The REGISTER AUTO PLOT function can be selected via the SAVE/PLOT menu, if PLOT was selected before in the DIGITAL SELECT menu:

- Press pushbutton SAVE/PLOT, this results in the display of the SAVE/PLOT menu.

7 AUTO PLOT>

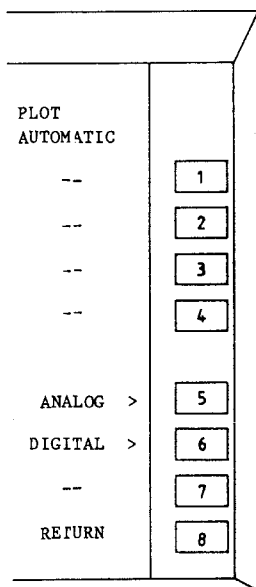

REGISTER AUTO PLOT is only selectable in the SINGLE-shot mode. (The text AUTO PLOT is not visible in an other horizontal mode).

In this mode, the contents of register R0 is automatically plotted each time that the memory contents is refreshed after a valid trigger signal.

If AUTO PLOT is selected, the PLOT AUTOMATIC menu, which now is extended with the function DIGITAL>, is displayed.

ANALOG> as described in the operating manual of the oscilloscope, remains possible.

7 6 DIGITAL>

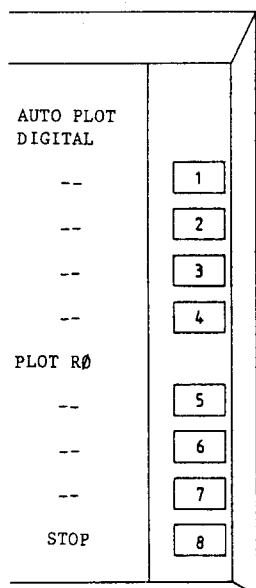

After selecting DIGITAL, the AUTO PLOT DIGITAL menu is displayed and the contents of register R0 is plotted.

The plot size, the plot quadrant, the grid type and the plotter interface can be selected via the SELECT function of the SAVE/PLOT menu .

During the PLOT action, the AUTO PLOT DIGITAL menu is displayed and a message

***** PLOTTER ACTIVE *****

Changes are possible after plotter has stopped.

is displayed.

At the end of the DIGITAL AUTO PLOT action, menu PLOT AUTOMATIC is displayed again, and the instrument waits for another single shot acquisition to be plotted.

- 7 6 1 --
- 7 6 2 --
- 7 6 3 --

7	6	4	--
7	6	5	--
7	6	6	--
7	6	7	--
7	6	8	STOP

A PLOT action can be interrupted by pushing softkey STOP. The PLOT AUTOMATIC menu is then displayed again. During a plot action it is not possible to switch to another softkey menu or to change any other function of the oscilloscope.

3.4.3.4 PLOT DIGITAL menu (see figure 3.5)

The SCREEN PLOT function can be selected via the DISPLAY menu if PLOT was been selected before in the DIGITAL SELECT menu:

- Press pushbutton DISPLAY, this results in the display of the DISPLAY menu.
- Press softkey POS Rn, this results in the display of the DISPLAY Rn POSITION menu.
- Press softkey PLOT>, this results in the display of the DISPLAY PLOT menu, which is now extended with the function DIGITAL>.

ANALOG> as described in the operating manual of the oscilloscope, remains possible.

6 DIGITAL>

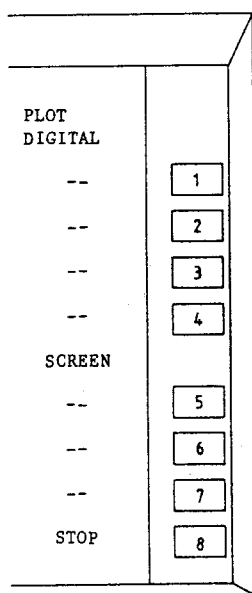

After selecting DIGITAL, a copy of the screen is made on a digital plotter. During the PLOT action, the PLOT DIGITAL menu is displayed and a message

***** PLOTTER ACTIVE *****
Changes are possible after plotter has stopped.
is displayed.

The settings made with the Y-POSITION control, the X-POSITION control and the X-EXPAND control remain.

At the end of the DIGITAL SCREEN PLOT action the menu DISPLAY PLOT is displayed again.

6	1	--
6	2	--
6	3	--
6	4	--
6	5	--
6	6	--
6	7	--
6	8	STOP

A PLOT action can be interrupted by pushing softkey STOP. The DISPLAY PLOT menu is then displayed again.

3.4.3.5 PRINT DIGITAL menu (see figure 3.4)

The REGISTER PRINT function can be selected via the SAVE/PLOT menu, if PRINT was selected before in the DIGITAL SELECT menu:

- Press pushbutton SAVE/PLOT, this results in the display of the SAVE/PLOT menu, which now is extended with the function DIGITAL>.

ANALOG> as described in the operating manual of the oscilloscope, is still possible.

6 DIGITAL>

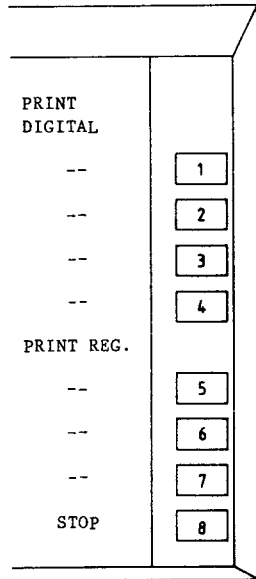

If DIGITAL is selected, the contents of the selected register is transferred to the digital print output. The default register is R0. Other registers to print as well as the printer type, the grid type and the printer interface can be selected via the SELECT function of the SAVE/PLOT menu.

During the PRINT action, the PRINT DIGITAL menu is displayed and a message

***** PRINTER ACTIVE *****
Changes are possible after printer has stopped.

is displayed.

At the end of the DIGITAL REGISTER PRINT action, the menu SAVE/PLOT is displayed again.

6	1	--
6	2	--
6	3	--
6	4	--
6	5	--
6	6	--
6	7	--
6	8	STOP

A PRINT action can be interrupted by pushing softkey STOP. The SAVE/PLOT menu is then displayed again. During a print action, it is not possible to switch to another softkey menu or to change any other function of the oscilloscope.

3.4.3.6 AUTO PRINT DIGITAL menu (see figure 3.4)

The REGISTER AUTO PRINT function can be selected via the SAVE/PLOT menu, if PRINT was selected before in the DIGITAL SELECT menu:

- Press pushbutton SAVE/PLOT, this results in the display of the SAVE/PLOT menu.

7 AUTO PLOT>

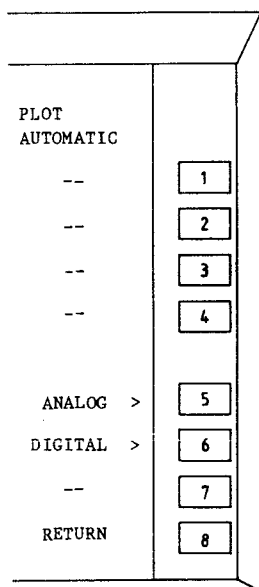

REGISTER AUTO PRINT is only selectable in the SINGLE-shot mode. (The text AUTO PLOT is not visible in an other horizontal mode).

In this mode, the contents of register R0 is automatically printed each time that the memory contents is refreshed after a valid trigger signal.

If AUTO PRINT is selected, the PLOT AUTOMATIC menu, which now is extended with the function DIGITAL>, is displayed.

ANALOG> as described in the operating manual of the oscilloscope, remains possible.

7 6 DIGITAL>

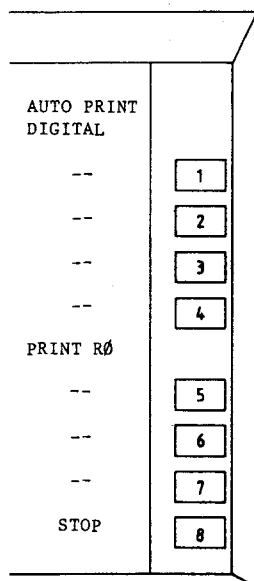

After selecting DIGITAL, the AUTO PRINT DIGITAL menu is displayed and the contents of register R0 is printed.

The grid type and the printer interface can be selected via the SELECT function of the SAVE/PLOT menu .

During the PRINT action, the AUTO PRINT DIGITAL menu is displayed and a message

***** PRINTER ACTIVE *****
Changes are possible after printer has stopped.

is displayed.

At the end of the DIGITAL AUTO PRINT action, menu PLOT AUTOMATIC is displayed again, and the instrument waits for another single shot acquisition to be printed.

- 7 6 1 --
- 7 6 2 --
- 7 6 3 --

7	6	4	--
7	6	5	--
7	6	6	--
7	6	7	--
7	6	8	STOP

A PRINT action can be interrupted by pushing softkey STOP. The PLOT AUTOMATIC menu is then displayed again. During a print action it is not possible to switch to an other softkey menu or to change any other function of the oscilloscope.

3.4.3.7 PRINT DIGITAL menu (see figure 3.5)

The SCREEN PRINT function can be selected via the DISPLAY menu if PRINT was selected before in the DIGITAL SELECT menu:

- Press pushbutton DISPLAY, this results in the display of the DISPLAY menu.
- Press softkey POS Rn, this results in the display of the DISPLAY Rn POSITION menu.
- Press softkey PLOT>, this results in the display of the DISPLAY PLOT menu, which is now extended with the function DIGITAL>.

ANALOG> as described in the operating manual of the oscilloscope, remains possible.

6 DIGITAL>

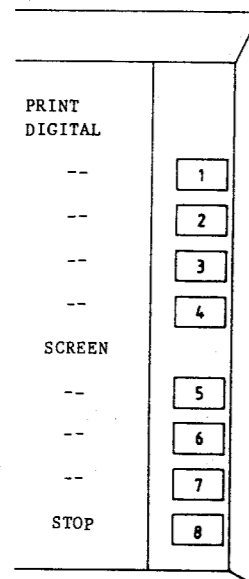

After selecting DIGITAL, a copy of the screen is made on a printer.
During the PRINT action, the PRINT DIGITAL menu is displayed and a message

***** PRINTER ACTIVE *****
Changes are possible after printer has stopped.

is displayed.

The settings made with the Y-POSITION control, the X-POSITION control and the X-EXPAND control remain.

At the end of the DIGITAL SCREEN PRINT action the menu DISPLAY PLOT is displayed again.

- 6 1 --
- 6 2 --
- 6 3 --
- 6 4 --
- 6 5 --
- 6 6 --
- 6 7 --
- 6 8 STOP

A PRINT action can be interrupted by pushing softkey STOP. The DISPLAY PLOT menu is then displayed again.

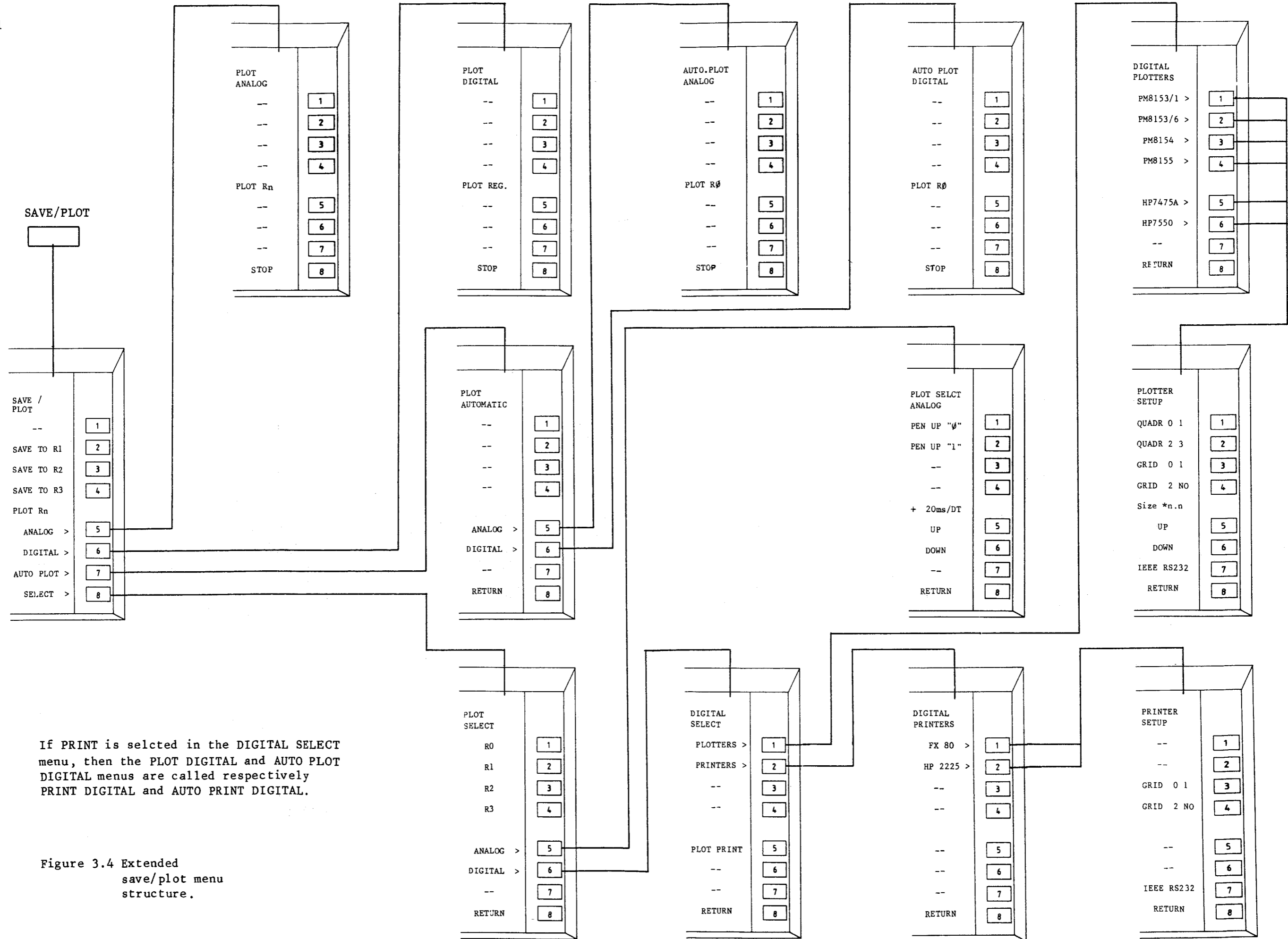
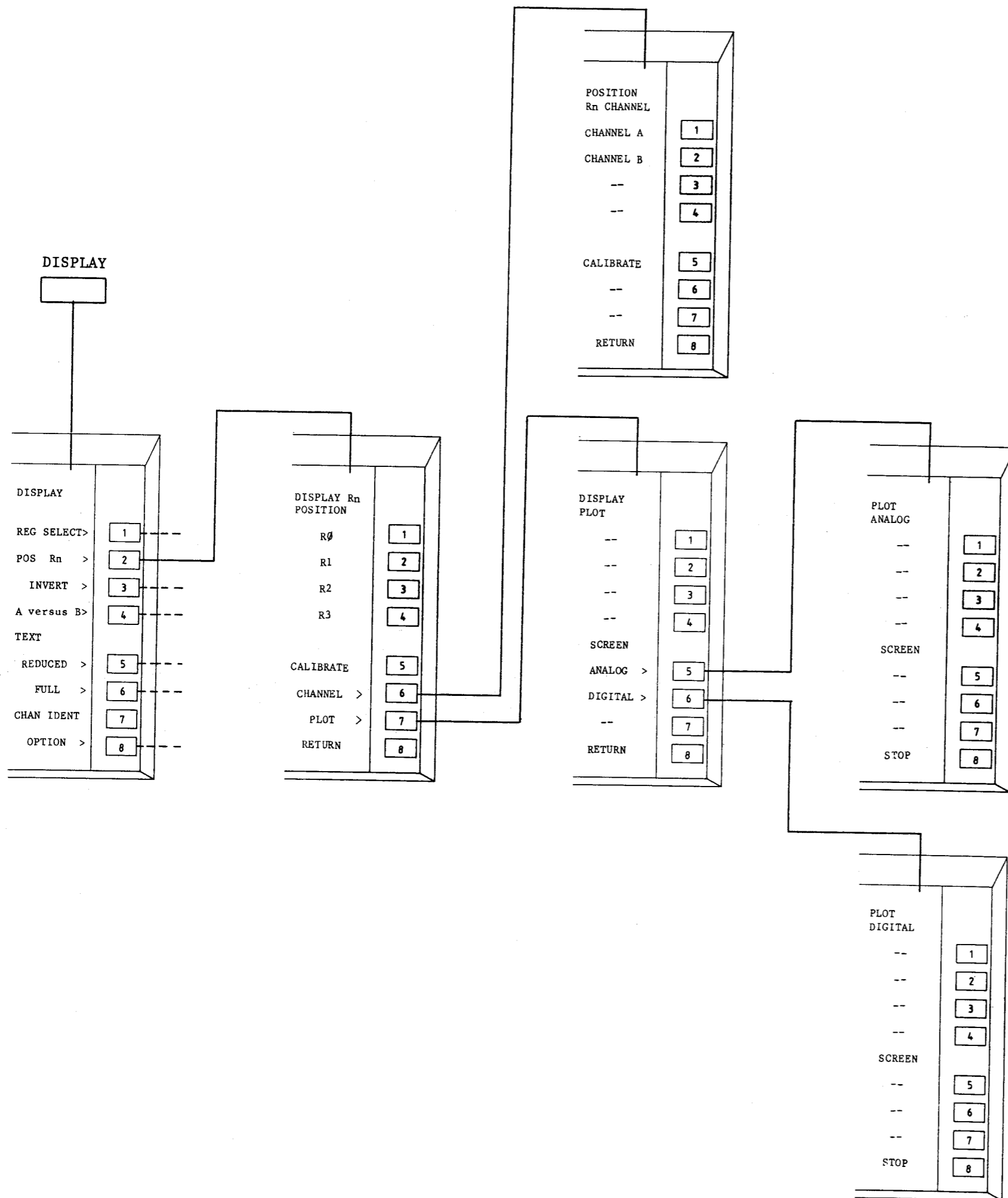

Figure 3.4 Extended save/plot menu structure.



If PRINT is selected in the DIGITAL SELECT menu (see figure 3.4), then the PLOT DIGITAL menu is called PRINT DIGITAL.

Figure 3.5 Extended display menu structure.

4. IEEE-488/IEC-625 BUS INTERFACE

4.1 INTRODUCTION

The IEC-bus interface is designed for interconnecting several instruments, programmable or non-programmable, to form a measuring system. International agreements on such a system (using byte serial, bit parallel operation) are defined in IEC Publication 625-1.

To simplify cabling and to allow for extension, the interface is organized as a bus-line system. All instruments are interconnected via a common set of 16 lines.

As the bus-line is common to all instruments, to communicate effectively the problems of interfacing have to be solved within the instruments themselves; i.e. they must be designed with inbuilt IEC-bus facilities. This enables the user to select the most suitable instruments for his system, regardless of make, knowing that interfacing is not a major problem.

These IEC-bus facilities to be described are the functional, electrical and mechanical requirements of instruments designed for connection to the interface, as defined in IEC Publication 625.

Major characteristics

- Instruments can be of various manufacture.
- Different data rates can be adapted.
- Asynchronous data transfer (up to 1 Mbyte/s) is possible without a controller.
- System flexibility allows rapid interchange of simple and highly complex equipment set-ups.
- No cabling problems.

Variants

One other standard conforms to the IEC 625-standard in all respects except for the type of interface connector used (see Section 4.12 Mechanical specifications). This variant is the American standard IEEE-488, sometimes referred to as:

- HP-IB HP Interface Bus.
- GPIB General-Purpose Interface Bus.

4.2. STRUCTURE OF THE IEEE-488/IEC-625 BUS

IEC-bus compatible instruments:

To satisfy the necessary requirements, interface functions are built into the instrument as active circuits. These circuits are dependent on the role of the instrument in the system and are additional to the normal device functions for which the instrument is primarily designed.

Basically, in any communication link there are:

Listeners

Devices addressed to receive data. More than one listener device can be active on the bus interface at a given time.

Talkers

Devices addressed to send data.
Only one talker device can be active on the interface at a given time.

Controllers

Instruments for addressing devices as talkers and listeners, also for sending special commands and control signals.
In addition to its control function, a controller must have a talk function and, generally, a listen function.

The data byte transfer control, or "handshake" functions ensure that valid data is offered by the talker, that all listeners are ready to accept it, and also verifies that they have accepted it.
The IEC interface includes other functions in addition to the above mentioned listen, talk and control functions.

NOTE: The terms, listener, talker and controller refer to selectable functions and any one device may be capable of being programmed to perform one or more of these functions, as shown in Fig. 4.1. For example, a device with a listener function is able to listen and is termed "listener" when addressed as a listener.

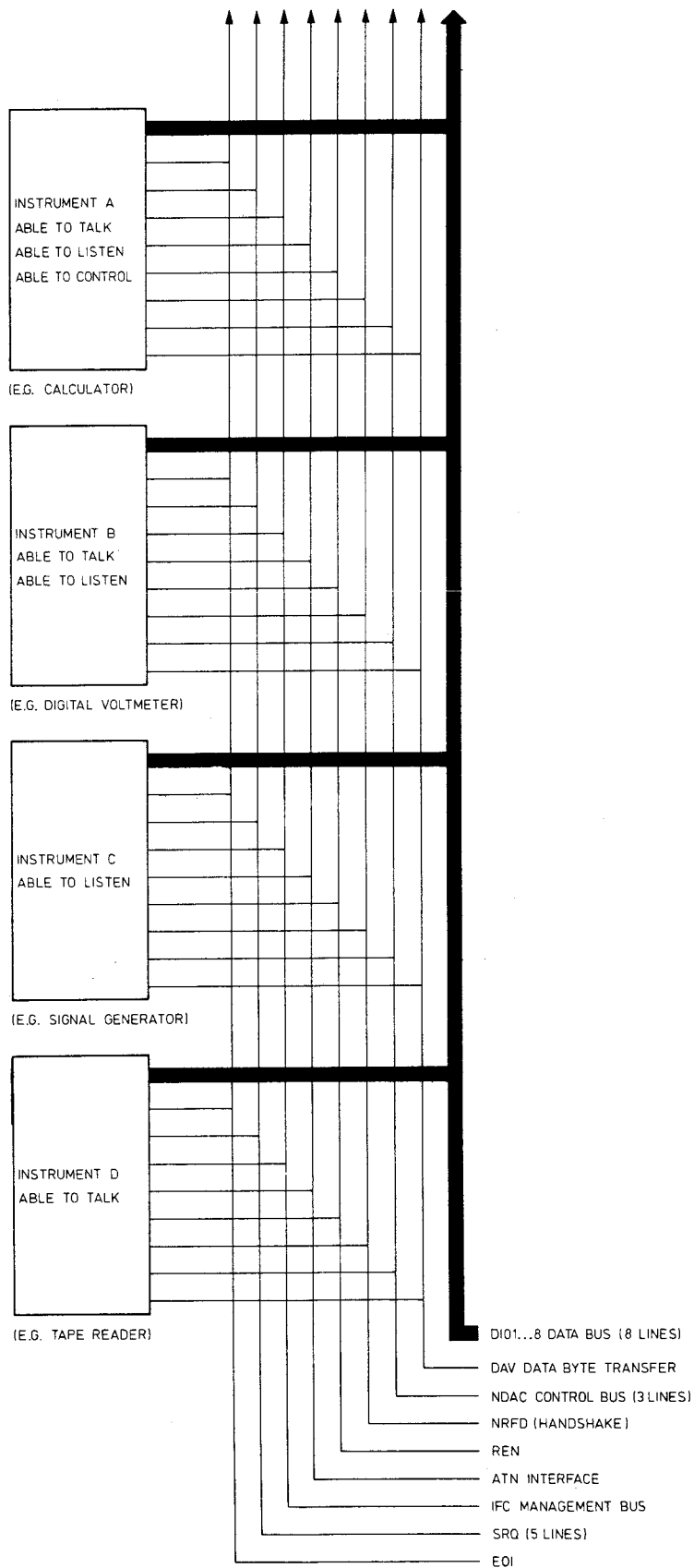

MAT2754

Figure. 4.1 Bus structure and interface capabilities.

4.3 BUS-LINE FUNCTIONS

The 16 bus-lines are divided into three functional groups:

- 8 data lines from the data-bus for multiline messages.
- 3 lines are used for data-byte transfer control (handshake lines).
- 5 lines are used for interface management.

The data-bus

The 8 bus-lines allocated for input/output data (DIO 1...8) are used for:

- Measuring data
- Programming instructions
- Status bytes
- Addresses
- Interface commands

A data byte consists of 8 parallel data bits. Where more information is needed, a complete message may comprise several data bytes in series. The maximum rate of data transfer over this two-directional asynchronous bus-system is 1 Mbyte per second.

The handshake-bus

These 3 lines control the exchange of data bytes between devices. The lines are briefly defined as:

DAV	DATA VALID (controlled by the source)
NRFD	NOT READY FOR DATA (controlled by the acceptor)
NDAC	NOT DATA ACCEPTED (controlled by the acceptor)

These handshake lines are activated to provide the necessary control whenever data bytes are sent over the 8 data-bus lines. They ensure that a source (generally a talker) regulates its speed to that of the slowest acceptor (generally a listener). During the transfer of a byte, the source handshake function in the interface section of a talker is active, and the acceptor handshake functions of listeners are also active.

The interface management-bus

The five lines of this group each have a specific control function between the controller and the other instruments in the system. Briefly the functions are as follows:

REN	REMOTE ENABLE A system controller facility to enable instruments to be switched between local (front panel) control and remote control.
ATN	ATTENTION A controller facility to select either interface messages or device-dependent messages.

- IFC INTERFACE CLEAR
A system controller facility to set the interface in a predefined state or to take over control in a multiple controller system.
- SRQ SERVICE REQUEST
A device function to ask for attention from the controller.
- EOI END OR IDENTIFY
Used by the talker to indicate the end of a multiple-byte transfer if ATN=0, or used by a controller to obtain response for parallel polling with ATN=1 (Identify message IDY=1).

4.4 THE HANDSHAKE PROCEDURE

The handshake procedure ensures the correct exchange of data-bytes between devices. It is the first level of the data transfer.

- DAV Data Valid
(controlled by the source)
When DAV=LOW, this indicates that a message on the data-bus is correct and suitable for acceptance.
- NRFD Not Ready For Data
(controlled by the acceptors)
NRFD=high indicates that all instruments are ready to accept a new data-byte.
- NDAC Not Data Accepted
(controlled by the acceptors)
NDAC=high indicates that all listeners have accepted the data-byte.

The handshake procedure is best explained by using an example of an addressed talker transferring data to a number of listeners.

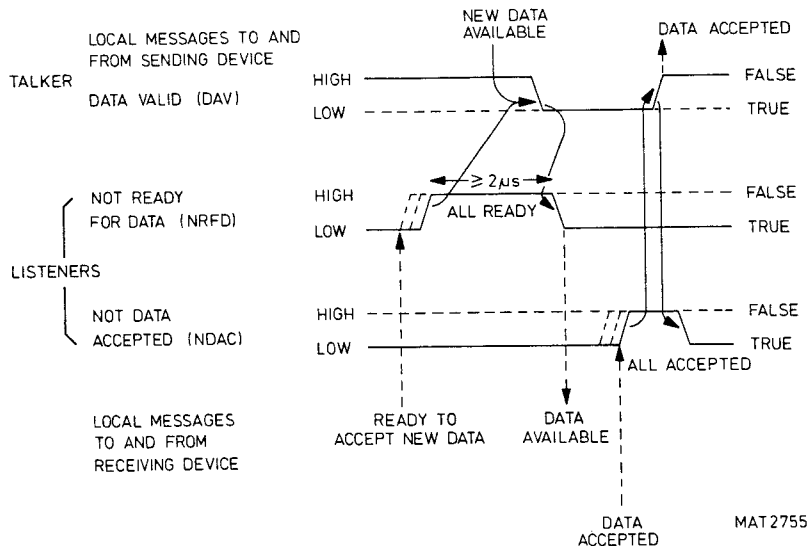

Figure 4.2 Handshake procedure.

To ensure that the NRFD line is only high when all listeners are ready for data, the individual NRFD lines of each interface are connected as a so called wired-OR configuration; i.e. all instruments programmed as listeners have to signal "high" outputs before this line becomes high; this is also valid for the NDAC line.

The procedure is as follows:

- At the start of a handshake cycle, the DAV line is at high level thus indicating that the data is not valid. The NRFD and NDAC lines are "low" which means that the listeners are not ready to accept new data.
- A talker may apply the first data-byte to the data-bus even when DAV is still "high" and if the NRFD line is still "low".
- When all listeners are ready to receive data, e.g. circuits are settled or previous data has been processed, a ready for data message (NRFD = "high") is given.
- After a short stabilizing time, the talker responds with a DAV "low", which indicates that data is valid to accept.
- The listeners react by setting NRFD "low" again and then read the data-byte.
- As soon as the data has been accepted, each listener makes its NDAC output "high", which results in the NDAC line going "high" when all the listeners have accepted data.
- The talker then responds with a DAV "high", declaring the data no longer valid.
- In response to DAV "high", all listeners make NDAC "low", which completes the cycle.

4.5

ADDRESSING

For efficient operation, devices must be properly identified at any given time as either a data source (talker) or a data acceptor (listener). Each device is therefore given a coded address as a means of recognition by the active controller. An address consists of 7 bits.

DIO lines	8	7	6	5	4	3	2	1
Address bits	x	b7	b6	b5	b4	b3	b2	b1
Talk address	x	1	0	└─ Device address ─┘				
Listen address	x	0	1					

The address of a device is determined by the position of the five address switches that select b5 to b1 (see ISO-code table, section 4.14 of this chapter). Switches b5 to b1 may not all be switched to 1 (address 31) because it means unlisten. It should also be noted that not all addresses are available, as some are already allocated to controllers. A controller addresses a particular instrument by placing the address code of that instrument on the 8 data lines and, at the same time, making ATN "true" (ATN=1). All devices on the bus compare the address code with their own address by using the message decoding function (part of the IEC interface in the device). The device having the same address as that on the data-bus performs the function of talker or listener, as defined by the address bits b6 and b7 of the address code. Therefore, for identification purpose it is necessary for instruments to have different addresses.

4.6 ADDRESS SETTING

The correct oscilloscope address can be set by performing the following steps through the several menus, starting in main DISPLAY menu of the oscilloscope (see fig. 4.4).

ACTUAL MENU	STEP NO	PRESSING	KEY#	NEW MENU
DISPLAY	1	OPTION>	8	DISPLAY OPTION 1
DISPLAY OPTION 1	2	OPTIONNAME>	1/5	OPTION INTERFACE
OPTION INTERFACE	3	IEEE 488>	1	OPTION IEEE 488
OPTION IEEE 488	4	TALK ONLY	1	OPTION IEEE 488
OPTION IEEE 488	4	LIST ONLY	2	OPTION IEEE 488
OPTION IEEE 488	4	ADDRESSED	3	OPTION IEEE 488
OPTION IEEE 488	5	ENTER	4	ENTER IEEE ADDRESS
ENTER IEEE ADDRESS	6	Now it is possible to key-in the desired address of the device, by entering the numbers via the numeric keyboard (2 positions). CLEAR: Clears the already entered address.		
ENTER IEEE ADDRESS	7	RETURN	8	OPTION IEEE 488
OPTION IEEE 488	8	RETURN	8	OPTION INTERFACE
OPTION INTERFACE	9	RETURN	8	DISPLAY OPTION 1
DISPLAY OPTION 1	10	RETURN	8	DISPLAY

Figure 4.3 Address setting in steps.

At delivery, or after switching-on an instrument without a memory back-up battery, the oscilloscope is set to device address 08, listen and talk (addressed).

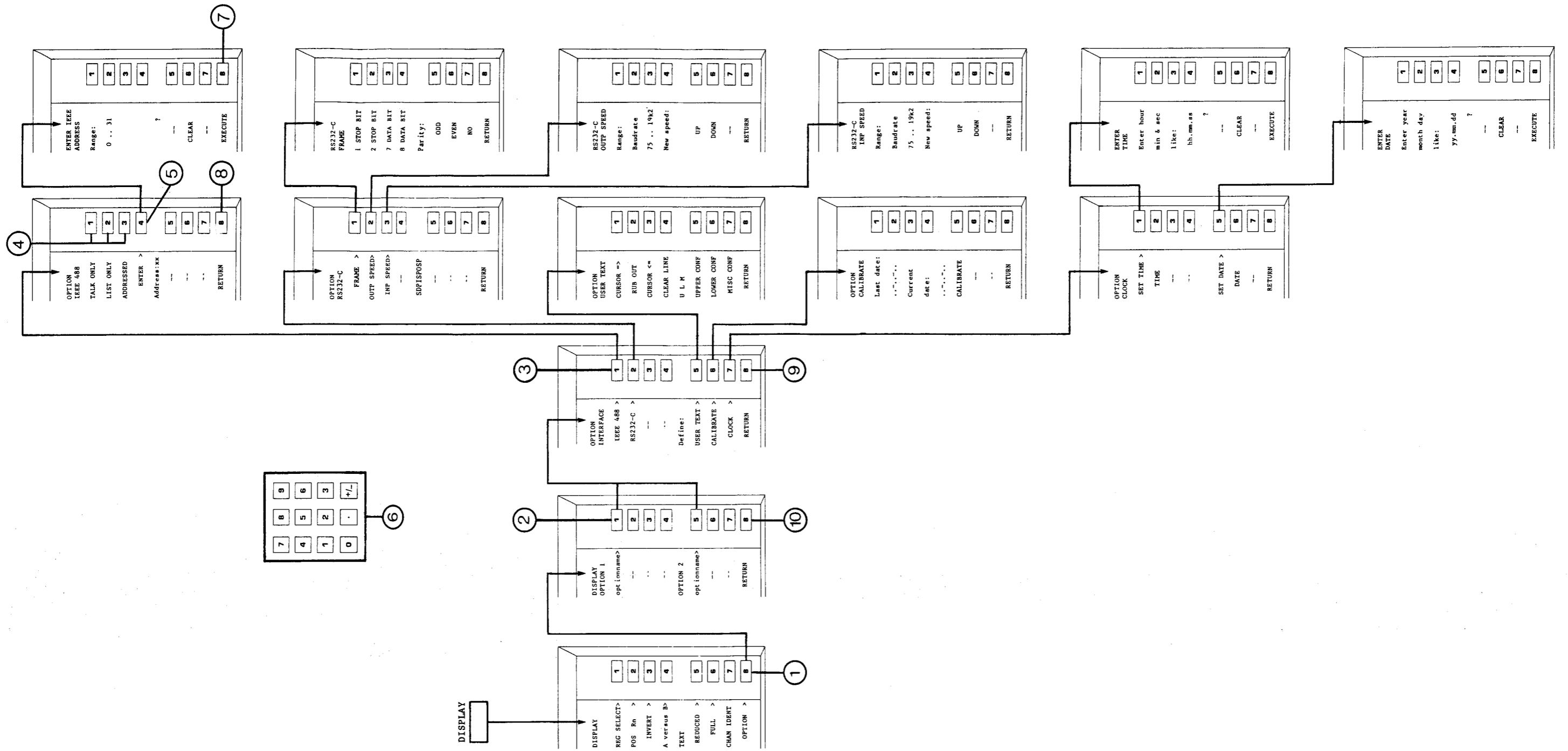

Figure 4.4 Address setting.

4.7

SRQ-SERVICE REQUEST AND SERIAL POLLING

Any device in a system can use the service request line SRQ to ask for service by the controller, even when the data-bus lines are otherwise occupied. An instrument that is in an error- or alarm-condition may request service by sending the SRQ message.

Furthermore, some device activities may take several seconds and it may not be economical to block the whole system until these activities are completed. By using the SRQ facility, it is possible for the controller to continue with other activities and to interrupt these when the time consuming operation is finished. When the SRQ signal is activated by one of the devices, the controller can interrupt all other activities and attend to the device which is requesting for service. First of all it must detect which device gave the SRQ signal. This is done by means of the serial poll facility. As an alternative to interruption, periodic checking of the SRQ line by the controller program is also possible.

If the service request facility is not implemented, only periodic polling of all devices remains as an alternative.

Serial polling

Up to 14 devices can give service request via the SRQ line, providing they each have a service request facility in their IEC interface. Such a device must also have a talk function with a serial poll facility; its message decoding section must be capable of decoding the bus commands SPE (Serial Poll Enable) and SPD (Serial Poll Disable).

If an instrument is serial polled, it puts its status byte on the data-bus. In the status byte, DI07 indicates whether an instrument has asked for service (SRQ=1). The other bits may give additional status information regarding the instrument polled; e.g. alarm, busy, ready.

Basically, the service request and serial polling is as follows:

- A device requests for service by activating the SRQ line.
- The controller receives a service request message and starts a serial polling routine by placing the device in the serial poll mode with the SPE bus command. This universal command is received by all devices.
- The controller then addresses each device in turn as talker.
- The device addressed as (serial polled) talker responds by setting its status byte on the data-bus.
- The particular device that has requested for service responds with an RQS "true" message (DI07 low) in its status byte.
- After the controller has inspected all status bytes, it terminates the serial poll mode with the universal bus command SPD (Serial Poll Disable) and carries out the necessary action for the device(s) that made a service request.

Note that when ATN becomes false, the last polled device becomes talker. Therefore, if necessary, the device may be unaddressed as talker by addressing another device as talker or the non-standardized interface message UNT (untalk; see ISO code table) may be sent.

Service can be requested for many reasons:

- The oscilloscope is ready after power up.
- The user request (URQ) pushbutton on the frontpanel of the oscilloscope is operated. The status word is then 64 (decimal).
- An event has occurred in the oscilloscope, e.g. autoset has finished.
- The device is in an erroneous condition; a programming error or operating error has occurred.

- The input buffer is full or nearly full. The sending device must stop data transfer to avoid blocking the interface, or to prevent loss of data bytes.
- New, valid data is available but the devices interface cannot output it; e.g. because it is not addressed as a talker.

4.8 THE DEVICE STATUSWORD

The device statusword reflects the status of the interface functions. However, since the interface functions can also be activated by device functions, the interface status may reflect some device condition; e.g. service request. The protocols relating to interface status data are covered by the relevant international standards.

The statusword can be read by programming a serial poll action.

```

Send UNlisten
Send SPE (Serial Poll Enable)
Make the oscilloscope TALKER
Make controller LISTENER
Read STATUS-word
Send UNTalk
Send SPD (Serial Poll Disable)

```

It may indicate incorrect process conditions (alarm or error status). See for error codes: section 7.4.

The device dependent bits in the STATUS-word of the oscilloscope specify the reasons for service request and/or reflect the status of the device functions.

The device statusword (8 bits) is built up as follows:

128	64	32	16	8	4	2	1	Decimal value (equivalent)
D7	D6	D5	D4	D3	D2	D1	D0	Data bits
EXT	RQS	AB	BS	EF3	EF2	EF1	EF0	Name

EXT : Extension bit.

This bit is not used and is always "0".

RQS : Request for service bit.

This bit is set if the oscilloscope has generated a service request.

AB : Abnormal bit.

This bit is set if an erroneous or alarm condition is detected.

The status is specified in the bits EF3 - EF0.

BS : Busy bit.

This bit is set if the oscilloscope is measuring (busy with programmed action).

EF3 - EF0 : Status bits.

The status reflected by these bits depends on the status of the AB bit.

If AB=0 then they are defined as:

EF3 : Power up service request.

After power up a service request is generated with this bit set.

EF2 : Statusword service request.

If a non-masked event happens in the oscilloscope a service request is generated with this bit set. See also next section about the device status event register and the device status enable register.

EF1 : Not used.

EF0 : Not used.

If AB=1 they are defined as:

EF3 : Not used.

EF2 : Data ready to be transferred.

New, valid data is available but the devices interface cannot transfer it; e.g. because it is not addressed as a talker.

EF1 : Not used.

EF0 : Programming error.

The device is in an erroneous condition; a programming error has occurred.

A service request with the Abnormal bit set, will override in a non-reversible way a status with the Abnormal bit cleared.

The following statuswords (decimal equivalent) are most usual:

0	Nothing of interest is happening.
64	URQ key is pressed.
68	A non-masked event has happened.
72	Power up passed successfully.
97	Programming error.
100	There is valid data ready, but it cannot be transferred.

By waiting for a service request after a GROUP EXECUTE TRIGGER command the controller can check when the oscilloscope is ready with that measurement.

4.9 THE DEVICE STATUS REGISTER AND THE DEVICE STATUS ENABLE REGISTER

A number of events in the oscilloscope may generate a service request with the AB bit reset and with the EF2 bit set (error code 68). After having read the statusword after such a service request, the DEvice Status Register (DESR) can be read with the DESR? command to detect which event caused the service request. Reading the status will clear all bits.

The device status register (16 bits) is built up as follows:

Least significant byte:

128	64	32	16	8	4	2	1	Decimal value (equivalent)

D7	D6	D5	D4	D3	D2	D1	D0	Data bits

SB7	SB6	SB5	SB4	SB3	SB2	SB1	SB0	Status Bit

Most significant byte:

..	2048	1024	512	256	Decimal value (equivalent)

D7	D6	D5	D4	D3	D2	D1	D0	Data bits

SB15	SB14	SB13	SB12	SB11	SB10	SB9	SB8	Status Bit

Status bit meaning if set:

- SB0: Since the last restart of the acquisition at least one acquisition was compared to the reference register (refers to SAVE or STOP on DIFFERENCE action).
- SB1: Since the last restart of the acquisition at least one acquisition had parts that were found to be outside the envelope contained in the reference register (refers to SAVE or STOP on DIFFERENCE action).
- SB2: Since the last restart of the acquisition the most recent acquisition had parts that were found to be outside the envelope contained in the reference register (refers to SAVE or STOP on DIFFERENCE action).
- SB3: Autoset has finished
- SB4: Auto-offset has finished.
- SB5: Calibration has finished.
- SB6: A mathematical calculation has started.
- SB7: A mathematical calculation has finished.
- SB8: A cursor measurement has started.
- SB9: A cursor measurement has finished.
- SB10: A single/multiple shot/scan has started.
- SB11: A single/multiple shot/scan has finished.
- SB12: Reserved for future expansions.
- SB13: Reserved for future expansions.
- SB14: Reserved for future expansions.
- SB15: Reserved for future expansions.

These events can be disabled (masked) by the DEvice Status Enable Register (DESE). By setting the corresponding bit in the DESE register an event will not generate a service request.

After a service request due to an unmasked event (error code 68) further service requests with error code 68 are disabled until the DESR has been read.

To control the DESR and the DESE register the following commands are added:

```
DESE XXXXX
DESE ?
DESR ?
```

These commands are described in chapter 7.

NOTE : Be carefull when using the DESE and DESR facility. Because of the continuous nature of calculations, measurements and the SAVE/STOP ON DIFFERENCE function, you may get again a service request right after you read the DESR. This may cause problems in application programs, which are not set up for this. A good advice may be to disable events before reading the DESR by programming DESE 0 after receiving a service request with error code 68.

4.10 DATA TRANSFER RATE AND TIMING SPECIFICATIONS

Determining the data transfer rate of the IEC bus is rather complex and depends upon the handshake timing of the acceptor and the source. In most applications however, the talker and listeners will cause a lot of overhead times, additional to the data transfer times of the handshake. This section only deals with handshake timing. To be able to calculate and to predict the time required to transfer a databyte (dab) over the bus, the handshake process itself has to be examined; the times in this process that are of interest to the transfer rate are to be determined. The handshake process between a source and a single acceptor is shown in fig. 4.5.

A source declares its sent data valid (DAV = low) at the moment that the databyte is stabilized on the DIO-lines and the acceptor is ready to receive a databyte (NRFD = high). At the moment that the DAV message becomes true the acceptor will respond to it and starts the input of the databyte; it will load the byte into its input buffer. At the moment that the input process is terminated, the databyte is accepted. This is indicated on the handshake bus by the NDAC-line becoming high (DAC=1).

The DAC-message only indicates that the databyte is accepted. The DAC-message does not indicate that the acceptor is ready again to accept the next databyte. The receiving device has first to implement the accepted byte before it is able to receive a next character; a certain time may be required for printing the received character or for implementing and executing the command (if the received character is to be regarded as control data).

Furthermore, the DAC-message indicates to the source that it may remove the byte from the databus and can send the next databyte. Upon receipt of this DAC-message, the source declares its data invalid (DAV=0) and removes the data from the bus. The source will start a procedure to pass the next databyte to the bus. After this new databyte has been transferred to the bus, a certain settling time is required to stabilize the signals on the DIO-lines. The source is ready to start a new handshake cycle after this settling time. If the acceptor device had already completed the implementation of the previous databyte at this time and is ready to receive the next databyte (RFD=1), the source will declare its new data valid: the handshake cycle starts again.

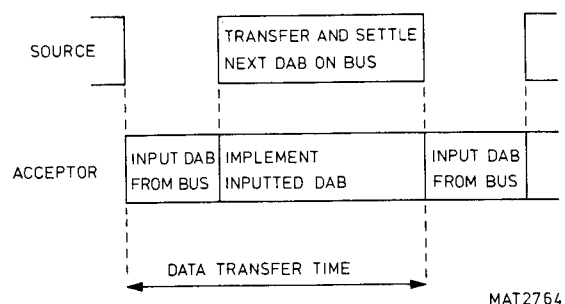
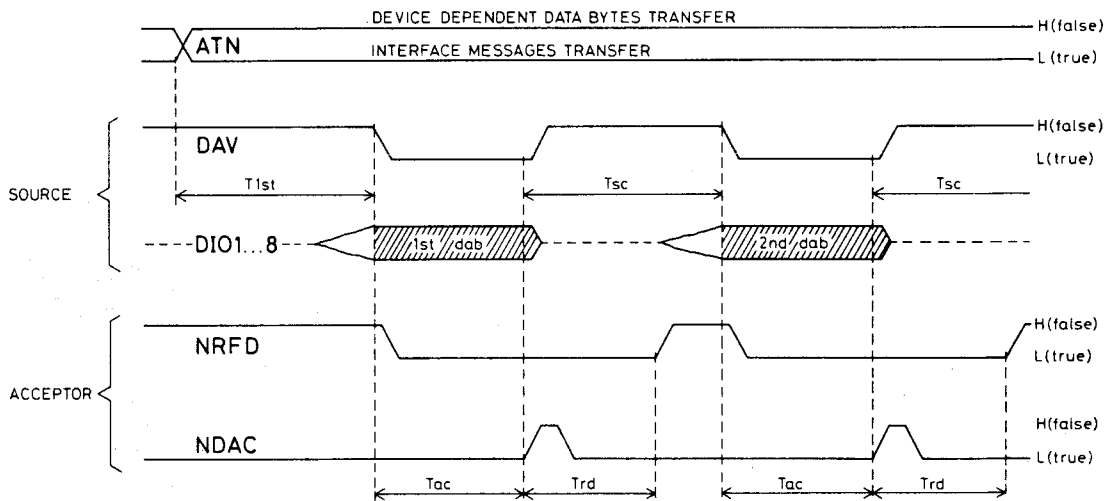

Figure 4.5 Data transfer time.

In the situation described above the source takes more time to pass and settle the next databyte to the bus than the acceptor requires to implement the previous input databyte.

It is obvious that in this case the data transfer rate is determined by the acceptor as well as by the source. The total transfer time equals the time required for input of the data plus the time required and settle the next data to the bus.

In reverse, if the acceptor device takes more time to implement the data than the source takes to pass and settle the data, the data transfer rate is only determined by the acceptor device. The total transfer time equals the time required for input of data plus the time needed to implement this data. Thus an increase of the source speed will not increase the datatransfer rate at all.



NOTES: -This timing diagram is valid for single source and single acceptor.

See also chapter 3.2.6 of the instrumentation systems manual 9499 997 00411.

-Trd starts at the moment that the acceptor sets NDAC false.

MAT1466A

Figure 4.6 Timing diagram.

TIMING SPECIFICATION FOR DATA TRANSFER

Data transfer in DATA_TYPE DECIMAL mode:

Source Handshake Oscilloscope ---> Controller

- Tac = Controller depending
- Trd = Controller depending
- T1st = < 150 ms
- Tsc = < 10 us (see figure 4.6)

Example:

DAT ?

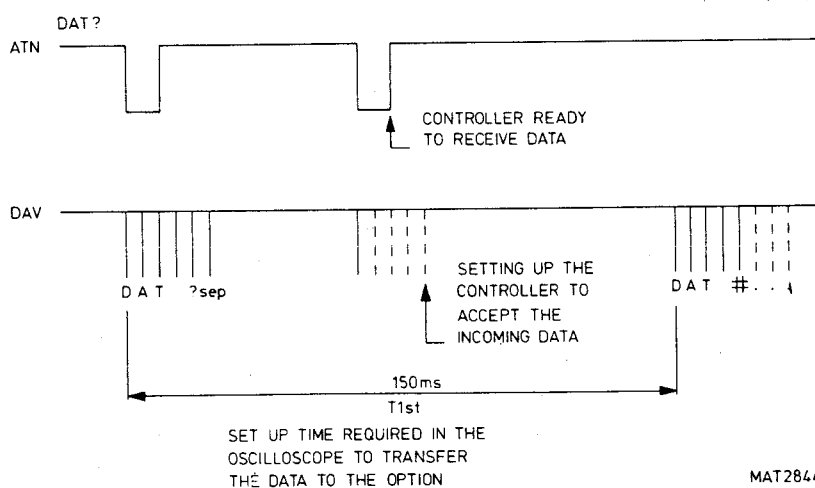

Figure 4.7 Source handshake timing.

Data bytes

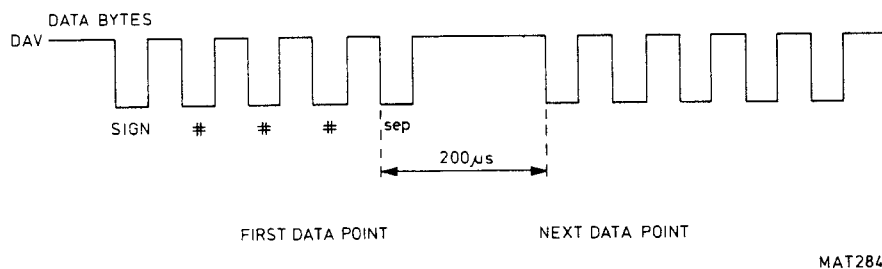

Figure 4.8 Source handshake timing.

Acceptor Handshake

Controller ---> Oscilloscope

- Tac = < 8 us (see figure 4.6)
- Trd = < 10 us (see figure 4.6)
- Tl1st = Controller depending
- Tsc = Controller depending

Example:

DAT

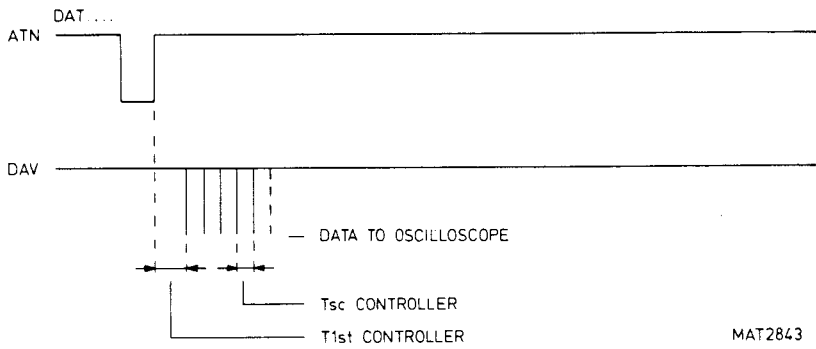

Figure 4.9 Acceptor handshake timing.

Data bytes

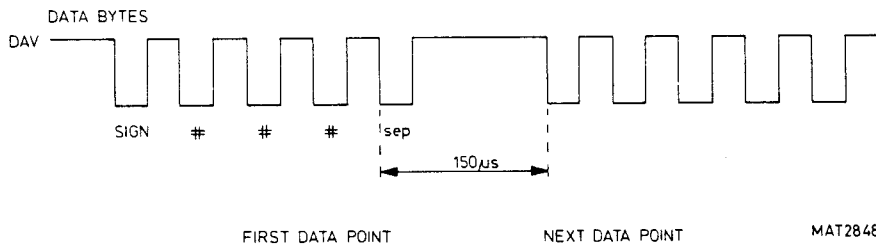

Figure 4.10 Acceptor handshake timing.

Data transfer in DATA_TYPE BINARY mode:

Source Handshake Oscilloscope ---> Controller

- Tac = Controller depending
- Trd = Controller depending
- T1st = < 150 ms
- Tsc = < 6 us

Example:

DAT ?

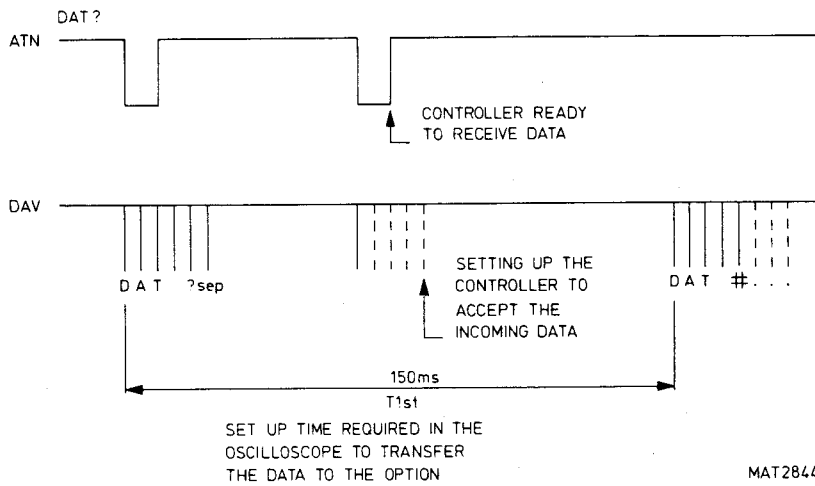

Figure 4.11 Source handshake timing.

Data bytes

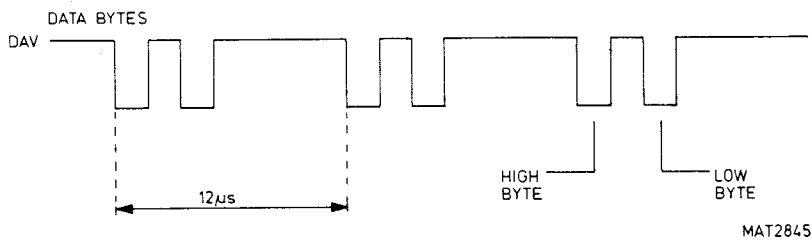

Figure 4.12 Source handshake timing.

Acceptor Handshake Controller ---> Oscilloscope

Tac = < 3 us (see figure 4.6)
 Trd = < 6 us (see figure 4.6)
 T1st = Controller depending
 Tsc = Controller depending

Example:

DAT

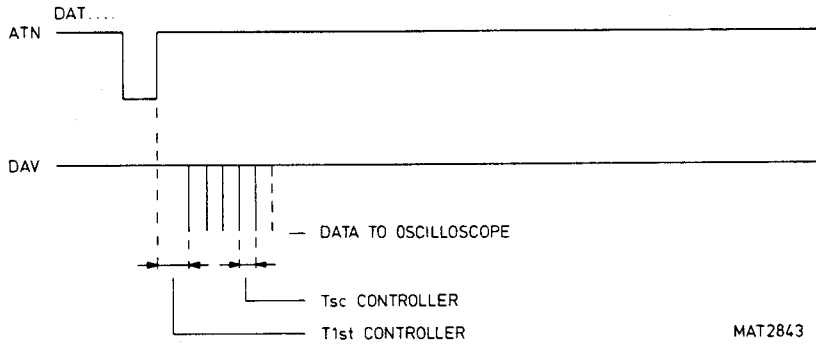

Figure 4.13 Acceptor handshake timing.

Data bytes

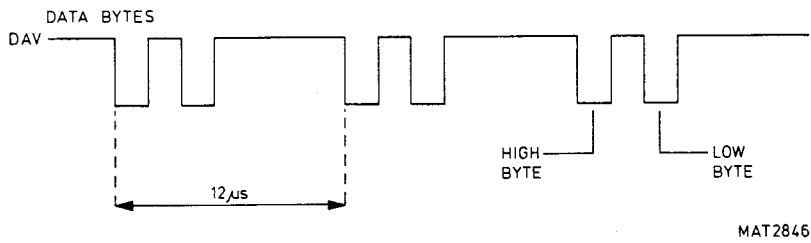

Figure 4.14 Acceptor handshake timing.

Transfer rate calculation (IEEE):

DATA_TYPE DECIMAL mode: (worst case if the controller does not limit the speed)

Example:

$$150 \text{ ms} + (5 \times 10 \text{ us} + 200 \text{ us}) \times 4096 = 1.174 \text{ s/register}$$

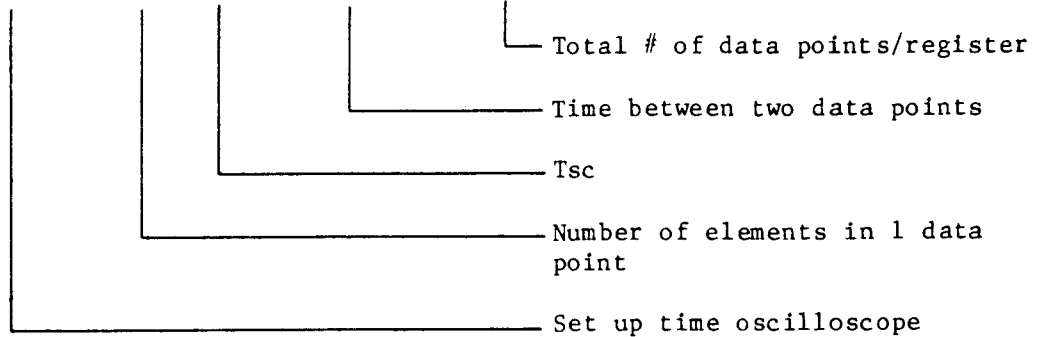

The transfer rate = 20 kb/s (worst case and excluding the set up time of 150 ms).

DATA_TYPE BINARY mode: (worst case if the controller does not limit the speed)

$$150 \text{ ms} + (6 \text{ us} \times 2 \times 4096) = 200 \text{ ms/register}$$

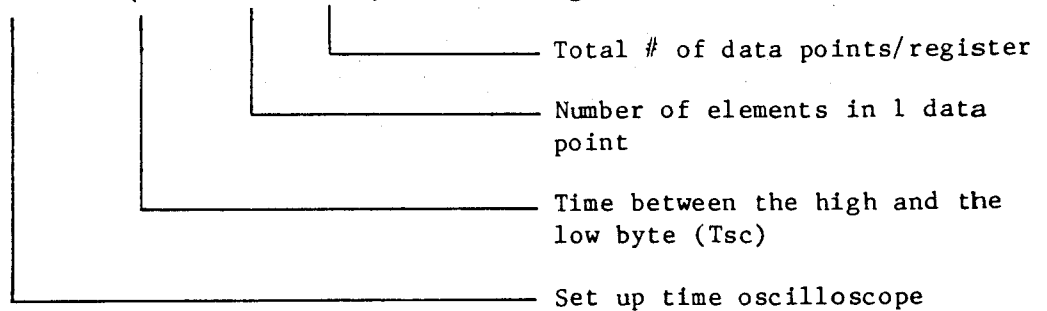

The transfer rate = 166 kb/s (worst case excluding the set up time of 150 ms).

4.11 INTERFACE FUNCTION REPERTOIRE

Interface function	Identification code	Description
Source handshake	SH1	Complete capability
Acceptor handshake	AH1	Complete capability
		- Basic talker
		- Serial poll
		- Talk only
		- Unaddress if MLA
Listener function	L3	- Basic listener
		- Listen only
		- Unaddress if MTA
Service request	SR1	Complete capability
Remote local	RL2	<u>No</u> local lock out
Device clear	DC1	Complete capability
Device trigger	DT1	Complete capability
Parallel poll	PPO	<u>No</u> capability
Controller	CO	<u>No</u> capability

4.12 ELECTRICAL SPECIFICATIONSSignal logic

The signal on the interface bus-lines are standardized in negative logic.

"high" state ≥ 2 V	0 false
"low" state $\leq 0,8$ V	1 true

Open collector driven circuits are used for the BUS signals.

4.13 MECHANICAL SPECIFICATIONS

The mechanical characteristics of the IEC interface are briefly outlined in this section. For more detailed information, refer to IEC Publication 625-1, Section 4 Mechanical Specifications, clauses 25 or 29.

Connectors

The IEC-bus cables are provided with 25-pole connectors, type MIL-C-24308. A plug and receptacle combined design allows cables to be stacked together in piggyback fashion and secured by a locking mechanism.

For the oscilloscope the American variant of the IEC system (the IEEE-bus), the 24-pole micro-ribbon, connectors (Amphenol or Cinch) is used. The receptacle type connector is located on the instruments rear side.

Cables

To ensure correct system operation, the cables for the interconnection of instruments must comply with the specification laid down in IEC-625. The cable should contain an overall shield and at least 24 conductors, of which 16 shall be used for signal lines and the balance used for logic ground returns.

Each of the signals: DAV, NRFD, NDAC, EOI, IFC, ATN, REN and SRQ, shall be a twisted pair together with one of the logic ground wires. The maximum capacitance existing between any signal line and all other lines connected to ground shall be 150 pF per meter.

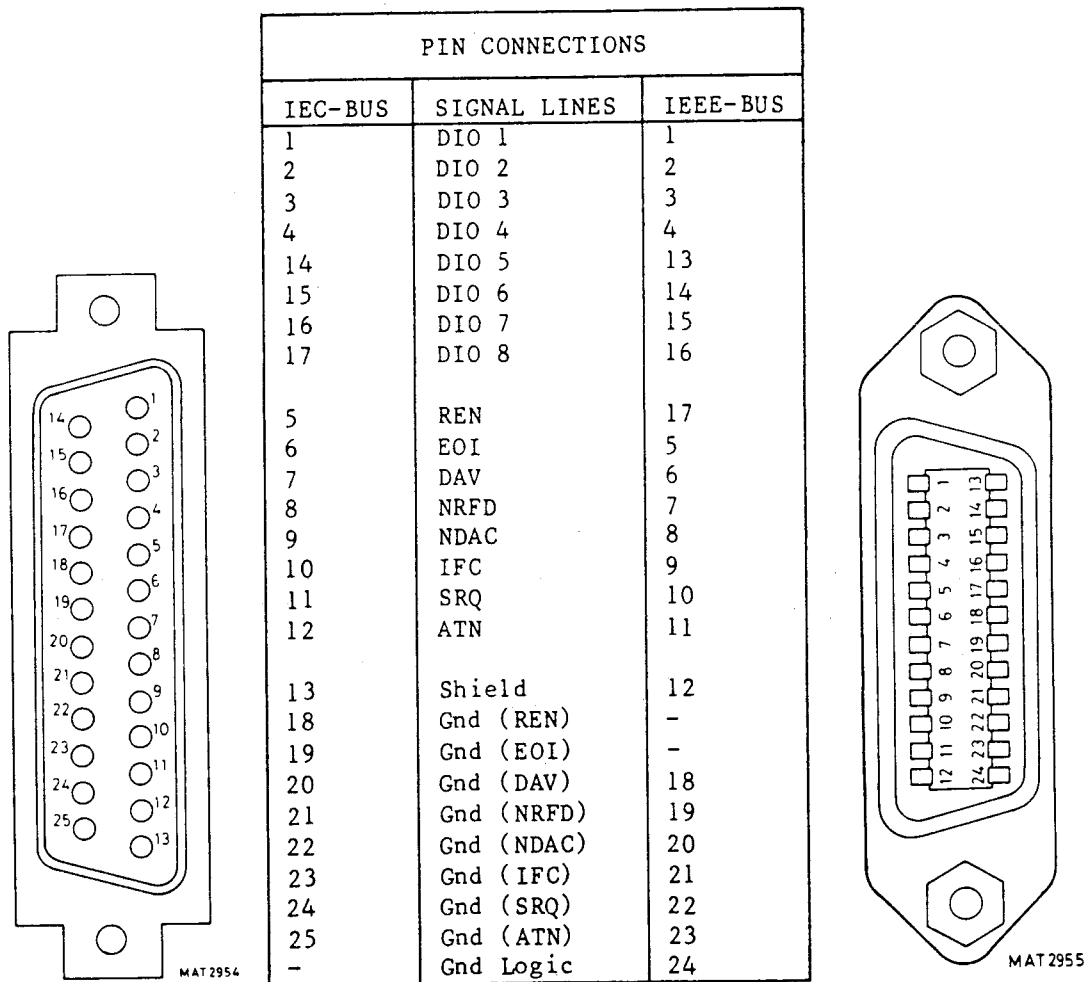

Figure 4.15 IEC-625-bus connector.

Figure 4.16 IEEE-488-bus connector.

4.14 SPECIFICATION IEEE-488/IEC-625 INTERFACE

Type of interface	ANSI/IEEE Std.488-1978	
-Connector	RFI/EMI shielded	Amphenol type 57LE-20240-7700D35G or similar, intermating with Amphenol 57FE series receptacles.
-Bus drivers	E2	Three-state (true = 0...0,8 V; false = 2...5 V).
-Interfacing function repertoire		
Source handshake	SH1	Complete capability.
Acceptor handshake	AH1	Complete capability.
Talker	T5	Basic talker : yes Serial poll : yes Talk only : yes Unaddress if MLA: yes
Listener	L3	Basic listener : yes Listen only : yes Unaddress if MTA: yes
Service request	SR1	Complete capability.
Remote local	RL2	No local lock-out.
Parallel poll	PP0	No capability.
Device clear	DC1	Complete capability.
Device trigger	DT1	Complete capability.
Controller	CO	No capability.
-Address	0...30	Software settable, through softkeys and menu.
Indicator	CRT	In softkeys area.
Default Address	8	At delivery or after switching-on without back-up battery.

-Timing

DATA_TYPE DECIMAL mode

Source: T1st < 150 ms
Tsc < 6 us

Acceptor: Tac < 8 us
Trd < 10 us

DATA_TYPE BINARY mode

Source: T1st < 150 ms
Tsc < 6 us

Acceptor: Tac < 3 us
Trd < 6 us

4.16 MULTI LINE MESSAGES (WITH ATN TRUE)4.16.1 GO TO LOCAL command

There are three ways to get the oscilloscope out of the remote situation and these are: hardware reset (power off, power on), and via an IEEE bus command GTL (Go To Local) or by activating the REN line. To get the oscilloscope out of its current remote situation send:

X0000001 (with ATN true)

After executing this command the oscilloscope is listening again to the knobs at the frontpanel.

4.16.2 GROUP EXECUTE TRIGGER command

It is possible for the controller to tell the oscilloscope when to start a measurement by using the IEEE bus GET (Group Execute Trigger) command.

This is done by sending:

X0001000 (with ATN true)

Since there are two modes of measurement (recurrent, single) there are two different interpretations possible for the oscilloscope:

Recurrent : no interpretation, measurements are continuous
Single : re-arm the single shot mode

For these modes there will be a service request after the measurement is ready. This service request will stay active until the status of the oscilloscope is loaded into the controller.

After this, the service request is reset by the oscilloscope and can be enabled by a new GET (Group Execute Trigger) command.

4.16.3 SELECTIVE DEVICE CLEAR command

The oscilloscope is capable of receiving and executing an SDC (Selective Device Clear) command from the IEEE bus.

The controller sets the selected oscilloscope in the selective device clear state by sending:

Device listener address followed by:

X0000100 (with ATN true)

On receiving this command the oscilloscope will, execute the following:

- * Clear the IEEE hardware interface and software work space. Interface settings (e.g. block separator) and local/remote status are not affected.
- * Place a new predefined frontpanel state.

4.16.4 DEVICE CLEAR command

The oscilloscope is capable of receiving and executing a DCL (Device Clear) command from the IEEE bus.

The controller sets all the devices in the system in the device clear state by sending:

X0010100 (with ATN true)

On receiving this command the oscilloscope will, execute the following:

- * Clear the IEEE hardware interface and software work space.
Interface settings (e.g. block separator) and local/remote status are not affected.
- * Place a new predefined frontpanel state.

5. RS232-C/V24 INTERFACE

5.1 INTRODUCTION

The serial interface described in this section is primarily intended to interconnect measuring instruments with other instruments to form a measuring system. A number of disciplines are already laid down for serial interfaces, but these disciplines mainly relate to interchanges between data terminal equipment (DTE) and data communication equipment (DCE). For measuring systems, the serial interfaces referred to must be regarded as connecting data terminal equipment to another DTE. As a consequence, these former disciplines and procedures are not always valid for measuring systems and modifications may be necessary as outlined in this chapter.

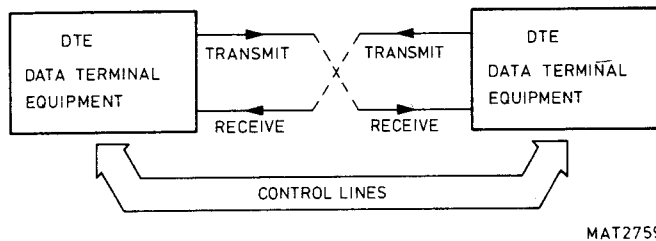

Figure 5.1 Typical configuration in measuring systems.

5.2 DEFINITION OF THE RS232-C INTERFACE

The V24 interface is based on the CCITT-Standard V24,28 giving specified signal characteristics for connecting data terminal equipment (DTE) and data communication equipment (DCE). V24 gives the functional specification of the circuits, whereas V28 specifies the electrical compatibility. The standard ISO 2110 assigns connector pin numbers to the circuits. All these documents are covered by the American Standard EIA-RS232-C except for the interchange circuit identification.

The mode of data transfer is digital, using the bit serial, byte serial method, over one signal line with common return.

5.3 DATA TRANSMISSION

For efficient data transfer, the following characteristics must be considered.

5.3.1 Synchronization

To enable correct detection of characteristics received, some synchronization between transmitter and receiver is necessary. This is achieved by adding framing information to the data (ISO 1177). For the oscilloscope asynchronous data transfer is used.

Asynchronous formatting is mostly used for measuring systems; common for low speed applications. It adds framing information bits to each data character. Framing information is one start bit preceding a data character and one or two stop bits following it.

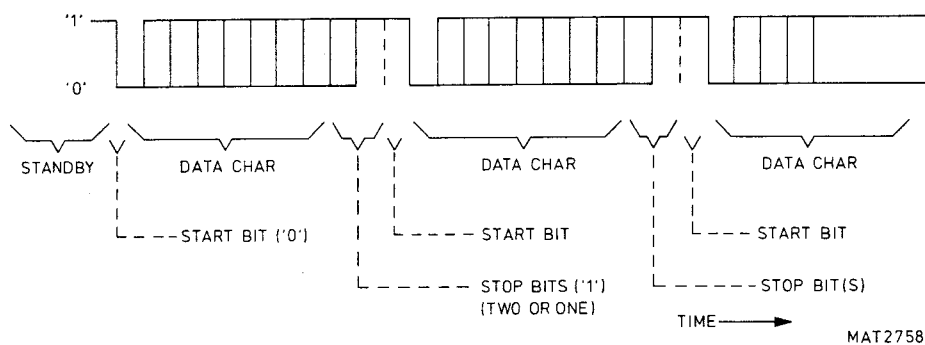

Figure 5.2 Framing.

Interfaces operating at speeds up to 1200 baud normally use two stop bits; those operating above this speed normally use one stop bit. In the "standby" state, when no characters are ready to be transmitted the transmit line is held in the logical "1" state. In asynchronous transmission mode, the even parity is the default value.

5.3.2 Character length

Different character lengths are possible. In measuring systems, 7 or 8 bit lengths are typical and are often switch-selectable. The character length excludes parity, start and stop bits. Normally, the ISO 7-bit code (ASCII equivalent) is used, the 8th bit being used for the parity. The least significant bit (LSB) is sent first.

5.3.3 Baudrate

The speed of the data transmission is specified in bits/sec by the baud rate, which must be selected to apply both to the transmitter and the receiver. Baudrates in use are:

75, 110, 150, 300, 600, 1200, 2400, 4800, 9600 and 19200 baud (bits/sec).

5.3.4 Interface transmission modes

A serial interface is said to operate in a simplex mode or a duplex mode depending on whether it can handle data transfer in one or both directions.

This interface handles data transfer in both directions; i.e. it can transmit and receive (Full Duplex mode).

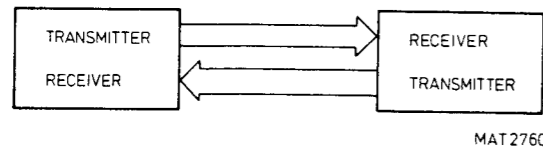

Figure 5.3 Transmission modes.

Full duplex means that:

- The interface can handle data transfer in both directions simultaneously.
- Transmitted data is assumed to be returned via the receive line (echoing).

5.4 INITIAL SETTING

The correct data transmission parameters can be set by performing following steps through the several menus starting in the main DISPLAY menu (see fig. 5.4).

Example: 1200 baud, 8 data bits, 1 stop bit, no parity.

ACTUAL MENU	STEP	PRESSING	KEY#	NEW MENU
DISPLAY	1	OPTION>	8	DISPLAY OPTION 1
DISPLAY OPTION 1	2	OPTIONNAME>	1/5	OPTION INTERFACE
OPTION INTERFACE	3	RS232-C	2	OPTION RS232-C
OPTION RS232-C	4	FRAME	1	RS232-C FRAME
RS232-C FRAME	5	1 STOP BIT	2	RS232-C FRAME
RS232-C FRAME	6	8 DATA BIT	4	RS232-C FRAME
RS232-C FRAME	7	NO	7	RS232-C FRAME
RS232-C EXECUTE	8	EXECUTE	8	OPTION RS232-C
OPTION RS232-C	9	OUTP SPEED>	2	RS232-C OUTP SPEED
RS232-C OUTP SPEED	10	UP/DOWN	5/6	RS232-C OUTP SPEED
		UNTIL 1200 (1K2)		
RS232-C OUTP SPEED	11	RETURN	8	OPTION RS232-C
OPTION RS232-C	12	INP SPEED>	3	RS232-C INPUT SPEED
RS232-C INPUT SPEED	13	UP/DOWN	5/6	RS232-C INPUT SPEED
		UNTIL 1200 (1K2)		
RS232-C INPUT SPEED	14	RETURN	8	OPTION RS232-C
<p>The In-and Output SPeed, the number of Data- and Stop bits, and the Parity are displayed now in the menu.</p> <pre> SDPISPOSP Output Speed 1K2 (1200) Input Speed 1k2 (1200) Parity N Data bits 8 Stop bits 1 </pre>				
OPTION RS232-C	15	RETURN	8	OPTION INTERFACE
OPTION INTERFACE	16	RETURN	8	DISPLAY OPTION 1
DISPLAY OPTION 1	17	RETURN	8	DISPLAY

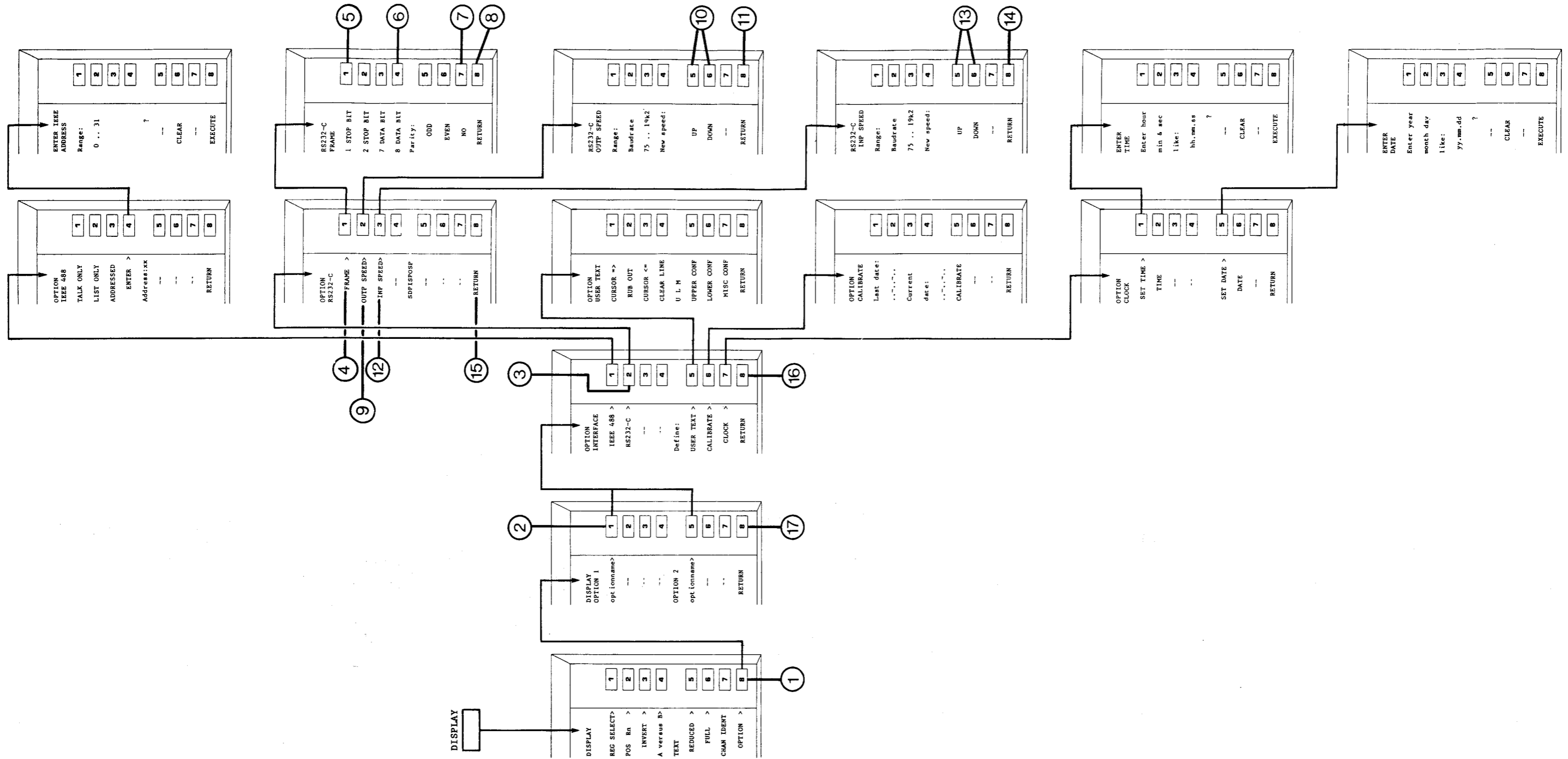

Figure 5.4 Initial setting.

5.5 SPECIAL INTERFACE FUNCTIONS

This section deals with a number of protocols that are not standardized in V24,28 documents, but are applied to instruments equipped with a serial interface.

5.5.1 Service request and serial polling

The service request and serial poll protocol were originally developed and intended for IEC interfaces, but its application has been extended to serial interfaces. This section deals with the implementation of the protocol for serial interfaces in Philips test and measuring instruments.

Serial interfaces do not provide a dedicated service request interrupt line. This means that the facilities for service request in devices equipped with these interfaces are somewhat restricted.

If a not masked reason for service request exists, the RQS-bit in the status byte indicates that service is required; if the reason to request for service is masked, the RQS-bit is not set. In any case, the reason may be specified in other bits of the status byte.

A controller operating with devices via serial interfaces can periodically poll the devices to check whether service is required or not. The controller executes a serial poll by sending the interface message ESC7 (1/B, 3/7) to a device. Upon receipt of such a poll command, the device will respond by transmitting the ASCII equivalent of the status byte.

If the oscilloscope status is LOCAL, an ESC7 should be terminated with an SPR. The oscilloscope will put the status word on the bus immediately after the receipt of the SPR.

If the oscilloscope status is REMOTE, an SPR is not necessary; the status word will be put on the bus immediately after the receipt of ESC7.

Example:

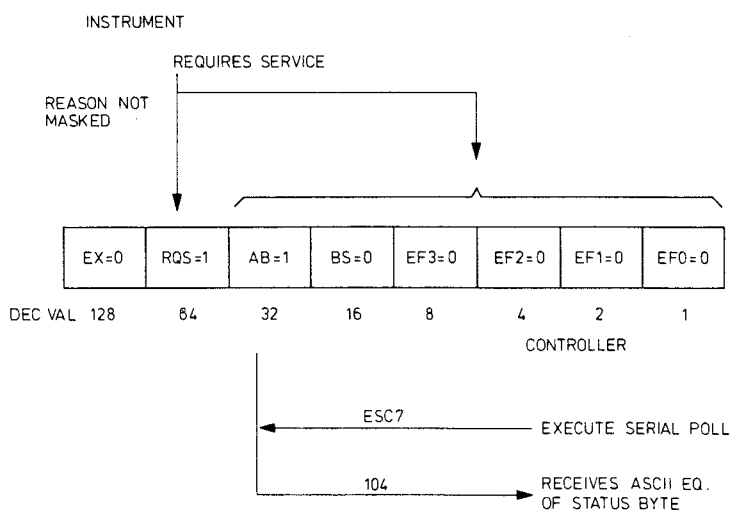

MAT2761

Figure 5.5 Serial poll action.

5.5.2 Remote local protocol

This protocol was also originally intended for application with IEC interfaces; but extended to serial interfaces. This section deals with the implementation for serial interfaces for Philips test and measuring instruments.

The following possibilities exist for devices equipped with a serial interface and provided with a remote local interface function.

Local to Remote

A transfer from the local to the remote state can only be performed by a controller by sending the interface message ESC2 (1/B, 3/2). Upon receipt of this "Go to remote" message, an instrument will unconditionally go into the remote state.

Remote to Local

A transfer from the remote to the local state can be performed either by the controller or by the device in the following ways:

the controller sends:

ESC1 (1/B, 3/1) Go to local
or ESC3 (1/B, 3/3) Go to local and unlock

the device sends (only if unlocked):

return to local (RTL=1)

After power on, the remote local function is always in the local state.

5.5.3 Device clear

Instruments equipped with a serial interface and provided with a device clear function, execute this function on receipt of the interface message ESC4 (1/B, 3/4) i.e. device clear. The device clear function returns the device function to a predetermined state. Interface settings (e.g. block separator) and local/remote status are not affected.

5.5.4 Device trigger

Instruments equipped with a serial interface and provided with a device trigger function, execute this function on receipt of the interface message ESC8 (1/B, 3/8) i.e. device trigger. The trigger starts a predetermined device action.

Pin no.	CCIT V24 circuit	RS232-C eq.	CCITT-V24 descr. For DTE-DCE	Cable connection	
				DTE	DTE
1	101	AA	Protective ground		
2	103	BA	Transmitted data (TxD)		
3	104	BB	Received data (RxD)		
4	105	CA	Request to send (RTS)		
5	106	CB	Ready for sending (CTS clear to send)		
6	107	CC	Data set ready (DSR)		
7	102	AB	Signal ground		
8					
9					
10					
11					
12					
13					
14					
15					
16					
17					
18					
19					
20	108.2	CD	Data terminal ready (DTR)		
21					
22					
23					
24					
25					

Figure 5.6 Pin and circuit allocation.

5.7 ELECTRICAL SPECIFICATIONSBus driver requirements

DATA (TXD, RXD)

Spacing "0" ≥ 3 V
 Marking "1" ≤ -3 V

CONTROL (RTS, CTS, DSR, DTR)

ON ≥ 3 V
 OFF ≤ -3 V

Current output ≤ 10 mA

Output (driver)

Line voltage (V_o) of output -7 V $\leq V_o \leq 7$ V
 impedance 300 Ohm

Input (terminator)

Line voltage (V_i) of input -25 V $\leq V_i \leq 25$ V
 impedance $3000 \leq R_1 \leq 7000$ Ohm

5.8 MECHANICAL SPECIFICATIONS

For RS232-C interfaces a 25-pole connector is used.

Connector requirements:

- The instrument is provided with a plug-type connector (male).
- The cable is provided with with receptacle connectors (female).
- The number of contact pins on the connector is 25.
- Locking screws are provided to enable cable mounting.
- The connector meets the military specification MILC-24308 or equivalent.

Cable requirements:

- The cable shall be as short as possible.
- The cable length may not exceed 15 meters.

However, where a longer cable is required, the total capacitance may not exceed 2500 pF.

- The cable will be a "null modem" cable. A null modem cable implies that the wire links between the pins needed to connect two DTEs are provided within the cable (e.g. pin 2 connected to pin 3 of the other terminal).

5.9 RS232-C CONNECTOR

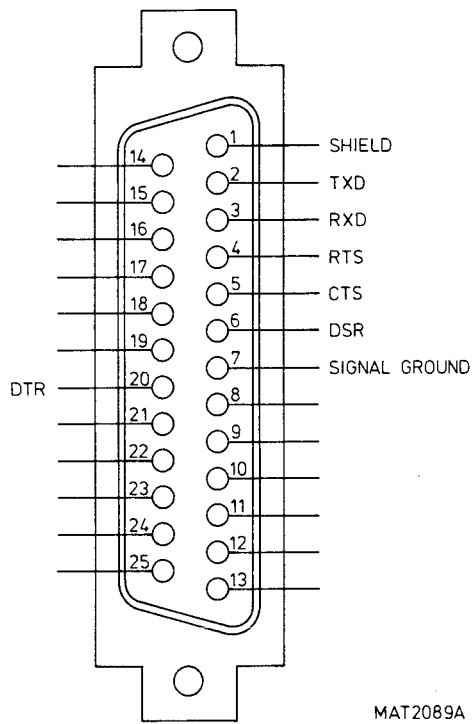

Figure 5.7 RS232-C connector.



6. PROGRAMMING AN OSCILLOSCOPE

6.1 DESCRIPTION OF POSSIBLE ACTIONS

The interface is capable to carry out the following actions:

SYSTEM FUNCTIONS:

- Program a "unit separator" (USP).
- Program a "block separator" (BSP).
- Program a "record separator" (SPR).
- Call for "identity" (IDT).
- Program a wait time (delay time after a BSP or an SPR) (WTD).

SUPER FUNCTIONS:

Front handling (FRO 0).

- Transfer of frontpanel settings from oscilloscope to controller.
- Transfer of frontpanel settings from controller to oscilloscope.

Register handling (REG 0, 1, 2 or 3)

- Transfer of register contents from oscilloscope to controller.
- Transfer of register contents from controller to oscilloscope.

SERVICE REQUEST:

- The oscilloscope can ask for service and will respond its status word when the controller executes a serial poll.

MULTI-LINE MESSAGES:

- Do a GROUP EXECUTE TRIGGER
- Do a GO TO LOCAL
- Do a SELECTIVE DEVICE CLEAR
- Do a DEVICE CLEAR
- Do a SERIAL POLL

In all examples the oscilloscope is assumed to be set to device address 8.

6.2 MESSAGE PROTOCOL FOR OSCILLOSCOPES

6.2.1 Introduction

This section deals with the user friendly messages to sent to an oscilloscope or to receive from an oscilloscope via a controller. The basic purpose of the message structure is to provide a flexible tool for moving instructions and/or data into and out of the oscilloscope.

A message record consists of a sequence of one or more message units.

MESSAGE RECORD

- A message unit is the smallest possible sequence of characters (or bytes) constituting a related data set, generated, processed or interpreted as a unit.
- A message block is a sequence of one or more related message units. In practice, the number of characters within a block is restricted.
- A unit consists of two parts. A header and a body.
- Header and body are always separated by a space (SR0).
- Units can be concatenated in a message.
- Units are always separated with a so called unit separator (SR1).
- Messages can be separated (using a block separator SR2 or a record separator SR3).

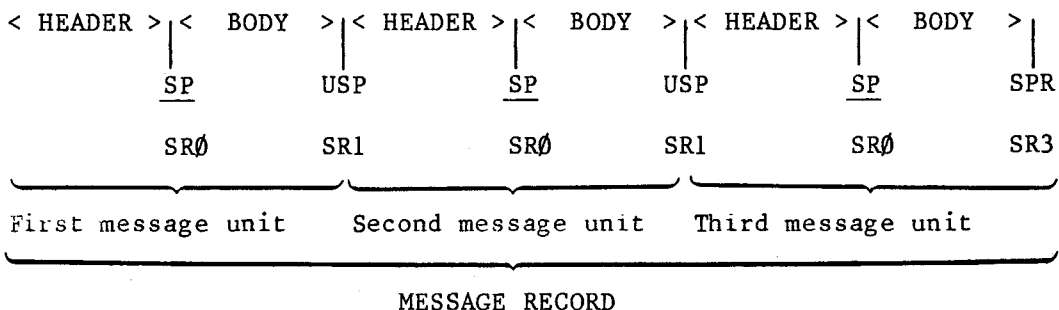

NOTE: - Only the last message unit can be a query unit (?).

Message structure

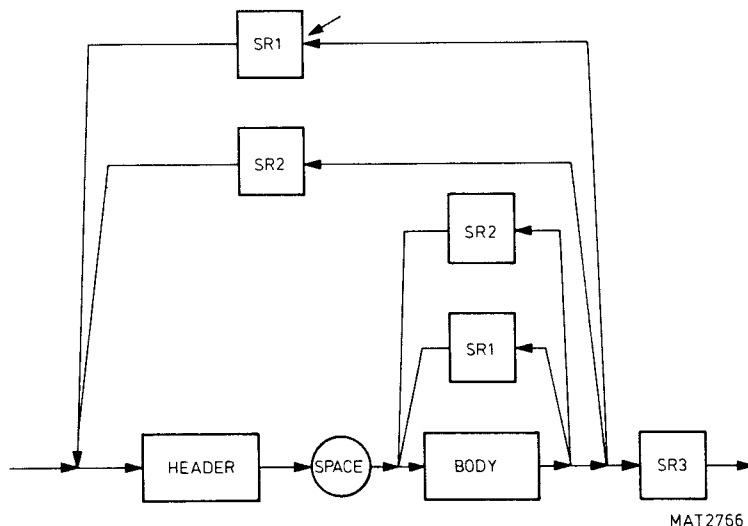

MAT2766

Figure 6.1 Message structure.

A message record is a sequence of one or more message blocks constituting the complete device-message. A message begins when a device starts sending data for the first time following a reset or a previously sent record separator; it ends with the record separator.

6.2.2 Separators

Separators are used to distinguish between the various parts in the message, and to mark the several hierarchical levels. In descending order of level they are denoted as SR3, SR2 and SR1, for respectively, the record-, block- and unit- separator.

Following separators are used:

TO SEPARATE A HEADER AND A BODY

	<u>IEEE:</u>	<u>RS232:</u>
Indicated as:	SR0	SR0
Preferred: <u>space</u>		
Hexadecimal representation	20	20
Decimal representation	32	32

TO SEPARATE TWO UNITS (UNIT SEPARATOR)

The unit separator is used within a block to distinguish between related message units. However, it is quite usual that the header of the next unit implies the unit separator.

	<u>IEEE:</u>	<u>RS232:</u>
Indicated as:	SR1	SR1
Preferred: <u>comma</u>	,	,
Hexadecimal representation	2C	2C
Decimal presentation	44	44

TO SEPARATE TWO BLOCKS OF UNITS (BLOCK SEPARATOR)

The block delimiter is used within a message to distinguish between message blocks. Also here it is common practice that the header of the next block implies the block separator if a message exclusively consists of blocks that only contain one message unit.

	<u>IEEE:</u>	<u>RS232:</u>
Indicated as:	SR2	SR2
Preferred: <u>linefeed</u>	LF	LF
Hexadecimal representation	0A	0A
Decimal representation	10	10

TO TERMINATE THE LAST BLOCK TRANSMITTED (RECORD SEPARATOR)

The record separator is used to terminate a message. It indicates that there is no additional information available. In IEEE interfaces the END message is sent (via the ATN and the EOI-lines), concurrent with the NL message on the data bus.

	<u>IEEE:</u>	<u>RS232:</u>
Indicated as:	SR3	SR3
Preferred: <u>linefeed + END</u>	LF + END	LF
Hexadecimal representation	0A	0A
Decimal representation	10	10

End activates the EOI interface management line.

6.2.3 Message units

HEADER indicating the type or quality of the data following in the body. They refer in general to the quantity of the data rather than to units.

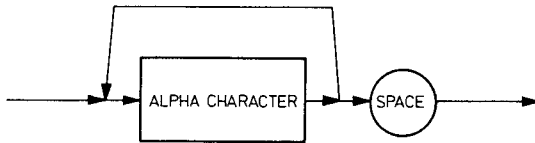

MAT2767

Figure 6.2 Header.

- Alpha characters are alpha numerical characters of the columns 4 and 5 of the ISO-code table see fig. 4.17 (only upper case).
- The header defines which function we want to program in an oscilloscope.

BODY containing the data to be transferred. It may represent different data types.

There are two types of bodies possible:

- a character data body
- a numerical data body

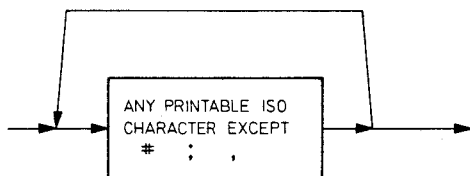
CHARACTER DATA BODY

MAT2768

Figure 6.3 Character data body.

There is no restriction for the length of the body, however it must be fixed per device function.

NUMERICAL DATA BODY

Numerical data can be represented in 3 different ways, depending upon the application:

- Implicit point notation - NR1
- Explicit point notation - NR2
- Scaled representation - NR3

Instruments that are able to implement a certain numerical representation (NR) are also able to implement a lower numbered NR.

Implicit decimal point notation (NR1):

$$(-32768 \leq NR1 \leq 32767)$$

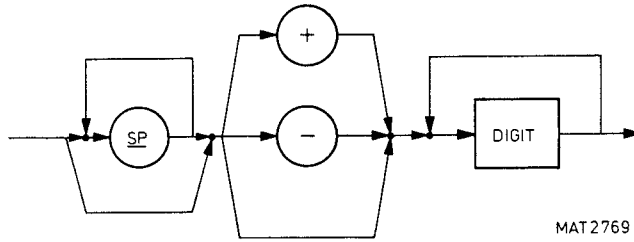

MAT2769

Figure 6.4 Numerical data body - NR1 notation.

Explicit decimal point notation (NR2):

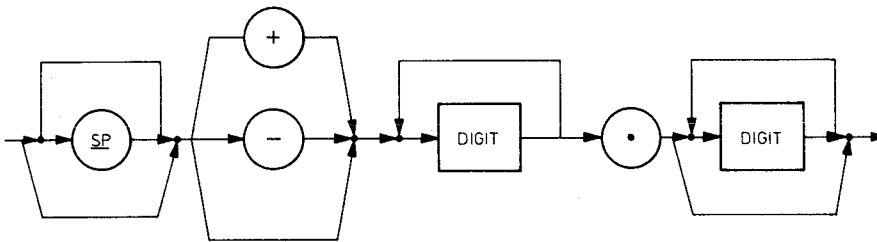

MAT2770

Figure 6.5 Numerical data body - NR2 notation.

The number zero can be noted as .0 (and of course 0, as NR1)

Scaled representation (NR3):

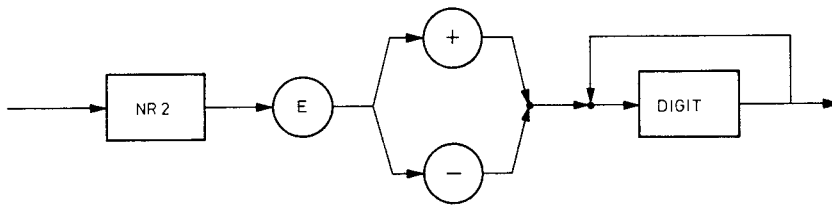

MAT2771

Figure 6.6 Numerical data body - NR3 notation.

Leading zero suppression (except for the exponent) is preferred for all numeric notations.

The body defines in this way the new state in which a function, defined by the previous header will end up.

Example:

Common Notation	NR1	Common Notation	NR2	Common Notation	NR3
238	+0238	32.4	+32.4	5600	+005.6E+03
-1	-0001	-3	-003.	0.02	+020.0E-03
0	+0000	0	+000.	-4.2	-004.2E+00

6.3 OSCILLOSCOPE PROGRAMMING

An oscilloscope can be set in the local or in the remote states:

Local state : The operator can control the oscilloscope manually, (REMOTE led off). In this state, the controller is able to switch the oscilloscope to "remote state".

Remote state: Only the controller on the bus can control the oscilloscope. (REMOTE led on).

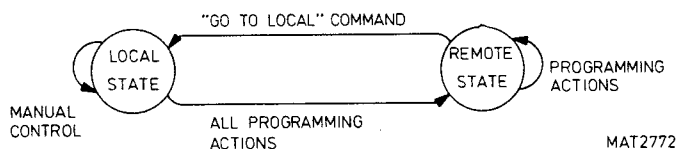

Figure 6.7 Two states of the oscilloscope.

In the oscilloscope we can divide the REMOTE state into two different states:

Front handling state : Used for programming a new acquisition setting.

Register handling state: Used for programming in stored settings and for data transfer. This function is typical for a digital storage oscilloscope.

The way to enter another state is to ask for that state. However, there are exceptions.

- IEEE commands like GET, SDC and DCL result in the front handling state when coming from the local state.
- Coming from the local state, any programming action, not preceded by a new state request is ending up in the front handling state.

Once in a certain state, a transition can only be made when a new state is programmed.

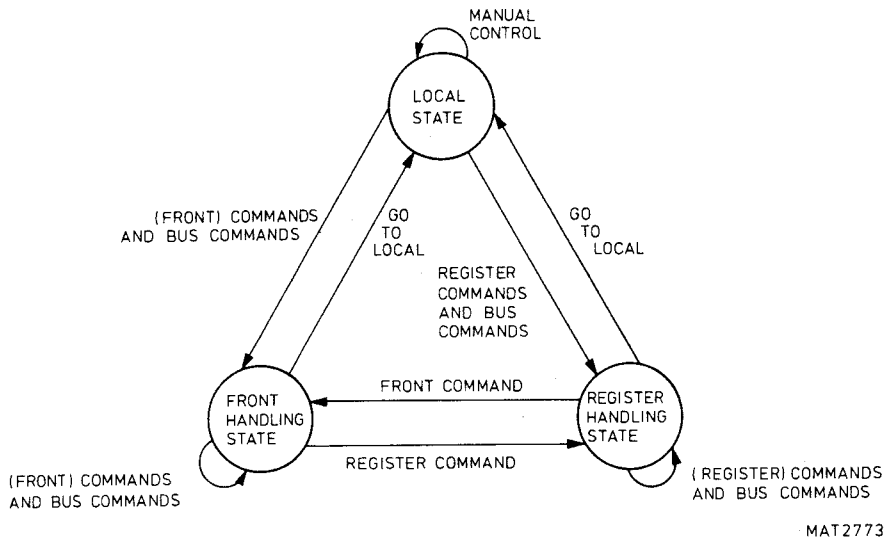

Figure 6.8 Oscilloscope states.

Commands between brackets are commands specific for that state.

- In the front handling state, we can change the actual settings of the oscilloscope.
- In the register handling state, we can change the stored settings.

Possible states within front and register handling state.

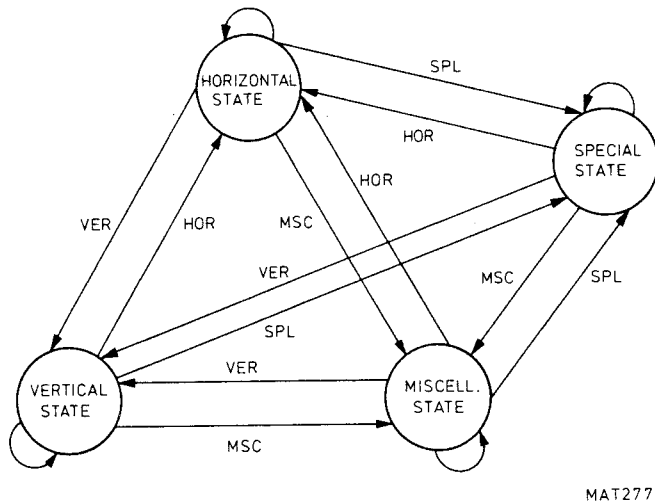
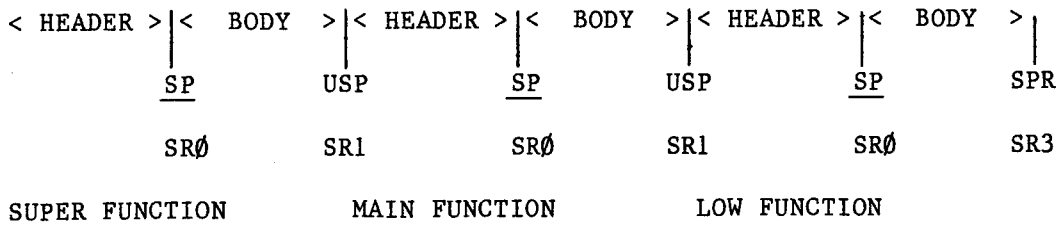

Figure 6.9 Detailed oscilloscope states.

Transition from one state to another can only occur if the command for entering that state is given.

For each oscilloscope function, which has to be programmed, first a SUPER FUNCTION must be selected, then a so-called MAIN FUNCTION and then one (or more) LOW FUNCTION(S).

So:



Example:

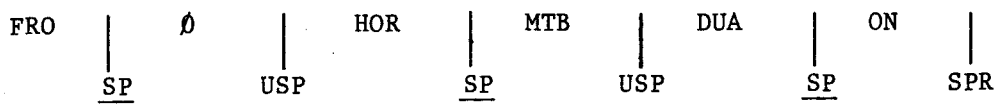

In this way the front panel is changed: dual triggering (of the horizontal main time-base) is switched on.

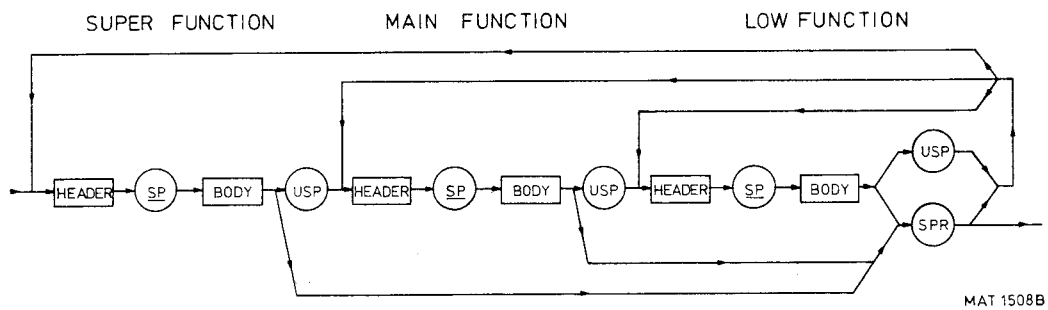

MAT 1508B

Figure 6.10 Programming structure.

7. PROGRAMMING CODES

This section deals with the code formats to be used for controlling the oscilloscope.

The codes are divided into a number of groups:

- SYSTEM CODES : Codes for the programming of separators, identity, and wait time delay.
- SUPER FUNCTION CODES: Codes for the transition to the register handling state or the front handling state.
- MAIN FUNCTION CODES : Codes for the transition within the register handling state or the front handling state.
- LOW FUNCTION CODES : Codes for the functions within a main function.
- DATA HANDLING CODES : Codes for the handling of the signal information which is stored in the digital memories. Data handling is a typical digital storage oscilloscope feature. A special group of programming codes is defined to read and write this information. Normally the signal data will be in NR1 notation. If data is transmitted in decimal notation, a multiple body can be used.
 - ! Data handling can only be done in the register handling state.
 - ! Data handling acts only on the data of the register which is currently selected by the bus.

NOTE: - It is always possible to use a "?" as a body. A "?" is defined for a bus controller to ask for information about a specific function. The answer from the oscilloscope will be, the header and the current situation (body or bodies).

- An error message occurs if a code is sent that is not implemented in the oscilloscope (see section 7.4).

7.1 SYSTEM CODES

The following section describes the system codes.

7.1.1 Separator (SPR)

The SPR-command programs the RECORD SEPARATOR (used at the end of a record or a number of HEADER/BODY combinations).

This command is very usefull when a controller does not know the default value LF (0A Hex, 10 Dec) as a RECORD SEPARATOR.

This instruction can program the oscilloscope to listen to the RECORD SEPARATOR the controller does know and to send the RECORD SEPARATOR the controller does know.

For output (from device to controller) this separator must be used. For input (from controller to device) termination is on one of the following conditions:

- At receipt of the specified separator characters.
- Any other non printable ISO-code character.
- As preferred separator the default value is LF (0A Hex, 10 Dec).

NOTE: It is not allowed to use the ESC-character as a separator (1B Hex, 27 Dec).

The ISO-character is the RECORD SEPARATOR character itself which can be filled in by the operator/controller.

Programming SPR must be done in the following sequence:

SPL INTERFACE usp INTF <...> usp SPR <...>

usp is the unit separator.

Low functions valid for main function SPL INTERFACE

PM33xx	Header:	Body:	Function or response:
20A 40	INTF	IEEE488.Ø	Selects the IEEE interface.
20A 40	INTF	RS232_IN.Ø	Selects the RS232 interface for data input.
20A 40	INTF	RS232_OUT.Ø	Selects the RS232 interface for data output.
20A 40	SPR	XX	Sets the RECORD SEPARATOR to the new value, given by the number XX. XX may be any number from 00 to 31 (decimal equivalent) except 27 (ESC).
20A 40	SPR	?	SPR XX XX is the decimal equivalent of the RECORD SEPARATOR. NOTE: Some returned characters may not be printable on the controller screen.

Example: SPL INTERFACE, INTF RS232_OUT.Ø, SPR 10 sets the separator for the RS232 interface for data output to linefeed decimal equivalent 10.

7.1.2 Block separator (BSP)

The BSP-command programs the BLOCK SEPARATOR (used between the blocks of a message).

This command is very useful when a controller does not know the default value LF (0A Hex, 10 Dec) as a BLOCK SEPARATOR.

This instruction can program the oscilloscope to listen to the BLOCK SEPARATOR the controller does know and to send the BLOCK SEPARATOR the controller does know.

Only to a single non printable ISO-character, default value is LF (0A Hex, 10 Dec).

NOTE: It is not allowed to use an ESC-character as a block separator (1B Hex, 27 Dec).

The ISO-character is the BLOCK SEPARATOR character itself which can be filled in by the operator/controller.

The BLOCK SEPARATOR is used as separator in data-transfer.

When the oscilloscope is sending characters to the controller, after 200 characters a BSP is sent unconditional.

Programming BSP must be done in the following sequence:

SPL INTERFACE usp INTF <...> usp BSP <...>

usp is the unit separator.

Low functions valid for main function SPL INTERFACE

PM33xx	Header:	Body:	Function or response:
20A 40	INTF	IEEE488.Ø	Selects the IEEE interface.
20A 40	INTF	RS232_IN.Ø	Selects the RS232 interface for data input.
20A 40	INTF	RS232_OUT.Ø	Selects the RS232 interface for data output.
20A 40	BSP	XX	Sets the BLOCK SEPARATOR to the new value, given by the number XX. XX may be any number from 00 to 31 (decimal equivalent) except 27 (ESC).
20A 40	BSP	?	BSP XX XX is the decimal equivalent of the BLOCK SEPARATOR. NOTE: Some returned characters may not be printable on the controller screen.

Example: SPL INTERFACE, INTF RS232_IN.Ø, BSP 10 sets the block separator for the RS232 interface for data input to linefeed decimal equivalent 10.

7.1.3 Unit separator (USP)

The USP-command programs the UNIT SEPARATOR (used between two units (header/body combinations)).

This command is very usefull when a controller does not know the default separator COMMA (27 Hex, 39 Dec) as a UNIT SEPARATOR.

This instruction can program the oscilloscope to listen to the UNIT SEPARATOR the controller does know and to send the UNIT SEPARATOR the controller does know.

The operator can program the UNIT SEPARATOR to which the oscilloscope will listen.

Any, ISO character can be used to define the UNIT SEPARATOR. The default character is the COMMA (2C Hex, 44 Dec).

The ISO-character is the UNIT SEPARATOR character itself which can be filled in by the operator/controller.

Programming USP must be done in the following sequence:

SPL INTERFACE usp INTF <...> usp USP <...>

usp is the unit separator.

Low functions valid for main function SPL INTERFACE

PM33xx	Header:	Body:	Function or response:
20A 40	INTF	IEEE488.Ø	Selects the IEEE interface.
20A 40	INTF	RS232_IN.Ø	Selects the RS232 interface for data input.
20A 40	INTF	RS232_OUT.Ø	Selects the RS232 interface for data output.
20A 40	USP	XX	Sets the UNIT SEPARATOR to the new value, given by the number XX. XX may be any number from 00 to 255 (decimal equivalent) except 27 (ESC). It is also possible to set the UNIT SEPARATOR directly, by typing the desired character on your keyboard. USP / will set the UNIT SEPARATOR to / (slash) (2F Hex, 47 Dec).
20A 40	USP	?	USP XX XX is the decimal equivalent of the UNIT SEPARATOR. NOTE: Some returned characters may not be printable on the controller screen.

Example: SPL INTERFACE, INTF IEEE488.Ø, USP 47 sets the unit separator for the IEEE interface to / (slash) decimal equivalent 47.

7.1.4 Call for identity (IDT)

The programmer can ask the PM number of the device and the used software release of the device and the option in use.

PM33xx	Header:	Body:	Function or response:
20A 40	IDT	?	IDT PM.....xxx / PM.....yyy xxx defines the used software release of the oscilloscope and yyy defines the used software release of the option.

7.1.5 Wait time delay (WTD)

For some controllers it is needed that the time between the transfer of two message blocks has to be stretched (only for IEEE). The default value (after power up) is about 1.5 ms.

Programming WTD must be done in the following sequence:

SPL INTERFACE usp INTF IEEE488.0 usp WTD <...>

usp is the unit separator.

PM33xx	Header:	Body:	Function or response:
20A 40	WTD	XXXXX	The WAIT TIME DELAY after a transfer of a message block is set to a value in ms defined by the number XXXXX which is a number between 0 ms and 65535 ms. The delay is inserted after a BSP or an SPR.
20A 40	WTD	?	WTD XXXXX XXXXX represents the previous programmed wait time delay in ms. NOTE: The actual WAIT TIME DELAY is XXXXXincreased with an internal delay of 1.5 ms. Example: WTD 12 = 13.5 ms

Example: SPL INTERFACE, INTF IEEE488.0, WTD 15 sets the wait time delay for the IEEE interface to 16.5 ms.

7.1.6 BUS LEARN

The actual frontsetting of the oscilloscope can be read into a controller or a previous saved frontsetting can be sent back to the oscilloscope.

SETUPS FROM OSCILLOSCOPE TO CONTROLLER.

The command is:

BINPROG ?

The oscilloscope will reply by sending two strings of predefined length:

1st string : "BINPROG"<space>"180 characters"<bsp>

2nd string : "BINPROG"<space>"182 characters"<spr>

Both strings must be fetched from the bus; if not, the scope will hang up and has to be released by a Device Clear command.

SETUPS FROM CONTROLLER TO OSCILLOSCOPE.

In principle the 1st and 2nd string have to be returned in exactly the same format and sequence as they have been received by the controller. The easiest way to do so is to buffer the 1st and 2nd string and return these strings to the oscilloscope.

IMPORTANT :

In no way the strings may be altered; nor the length neither its contents. Any change will result in a PROGRAMMING ERROR (status 97). The frontsetting of the oscilloscope will remain in the previous state.

The BINPROG command can be used to transfer frontsettings from one instrument to (several) others.

One restriction has to be made:

FRONTSETTING TRANSFER VIA THE INTERFACES, USING THE BINPROG COMMAND IS ONLY POSSIBLE BETWEEN INSTRUMENTS WITH THE SAME PM3320A/PM3340/PM8956A SOFTWARE RELEASE NUMBER.

The program in section 8.4.9 gives an example how to use the BINPROG command.

7.1.7 Number representation

In the command lists the following number representation is used:

X = digit (range 0 to 9) or decimal point

S = sign

E = exponent

Y = digit of exponent (range 0 to 9).

Examples:

XX : unsigned two digit number in the range 0 to 99

SXX : signed two digit number in the range -99 to +99

SXXXX : signed four digit number in the range -9999 to +9999

or

signed number in the range -99.9 to +99.9

XXESYY : unsigned floating point number (short notation)

YY is always a multiple of 3

Mantissa E Sign Exponent

XX E + YY

20E-03 (= 0.02)

SXXXXXXXXESYY : signed floating point number (long notation)

YY is always a multiple of 3

Sign Mantissa E Sign Exponent

+ XXXXXXXX E + YY

-50.000000E-03 (= -0.05)

7.2 SUPER FUNCTION CODES

7.2.1 Super function codes which can be selected for this oscilloscope:

PM33xx	Header:	Body:	Function or response:
20A 40	FRO	∅	Select the actual front panel.
20A 40	FRO	OFF	Switches off the front mode. (same effect as REG ∅).
20A 40	FRO	?	FRO ∅ or REG X X is the register number.
20A 40	REG	X	Select register. X = ∅ for R∅ X = 1 for R1 X = 2 for R2 X = 3 for R3
20A 40	REG	OFF	Switches off the selected register. (same effect as FRO ∅).
20A 40	REG	?	REG X or FRO ∅ X is the register number.

7.3 MAIN FUNCTION CODES AND LOW FUNCTION CODES

7.3.1 Main function codes which can be selected for this oscilloscope.

PM33xx	Header:	Body:	Function or response:	Page:
20A 40	VER	A	VERTical channel A settings.	7-10
20A 40	VER	B	VERTical channel B settings.	7-10
20A 40	VER	ADD	VERTical ADD settings.	7-16
20A 40	HOR	MTB	HORizontal channel settings.	7-18
20A 40	MSC	AUX	MiSCellaneous auxiliary settings.	7-30
20A 40	MSC	R∅	MiSCellaneous register R∅ settings.	7-36
20A 40	MSC	R1	MiSCellaneous register R1 settings.	7-36
20A 40	MSC	R2	MiSCellaneous register R2 settings.	7-36
20A 40	MSC	R3	MiSCellaneous register R3 settings.	7-36
20A 40	MSC	TRACE	MiSCellaneous trace transfer settings.	7-39
20A 40	SPL	INTERFACE	SPeciaL interface settings.	7-50
20A 40	SPL	TEXT	SPeciaL text settings.	7-53
20A 40	SPL	SERVICE	SPeciaL service settings.	7-55
20A 40	SPL	CURSOR	SPeciaL cursor settings.	7-57
20A 40	SPL	MATHEMATICS	SPeciaL mathematics settings.	7-64
20A 40	SPL	SETMEM	SPeciaL setting memory settings.	7-68

7.3.2 All main functions

A number of low functions are valid for all main functions.

7.3.2.1 TABLE I Low functions valid for all main functions

PM33xx	Header:	Body:	Function or response:
20A 40	SET	AUT	Executes the AUTO SET function.
20A 40	SET	STANDARD	Sets the oscilloscope to the default setting. This setting is identical to the setting after an autoset without any input signals.
20A 40	SET	?	SET AUT or SET INACTIVE
20A 40	DESE	XXXXX	Sets the DEvice Status Enable register to the value XXXXX. XXXXX is a value in the range 0 to 65535. A masked bit will not be set in the DESR if a corresponding event occurs.
20A 40	DESE	?	XXXXX XXXXX is a value in the range 0 to 65535, representing the mask bits for events.
20A 40	DESR	?	XXXXX XXXXX is a value in the range 0 to 65535, of which each set bit represents an occurred event. All bits are reset after this command.
20A 40	BINPROG	...	Transfer complete frontsetting to the oscilloscope. See also section 7.1.6.
20A 40	BINPROG	?	Two strings, representing the complete front setting of the oscilloscope. See also section 7.1.6.
20A 40	IDT	?	IDT PM.....xxx / PM.....yyy xxx and yyy define used software releases. See also section 7.1.4.

7.3.3 Main function VERTICAL

VER A, VER B and VER ADD are the main functions for the vertical channels of the oscilloscope.

The next tables give a clear overview of the available low functions per main function.

A request for the vertical settings within a selected main function can be done by programming VER ? .

The answer is dependent on the previously selected main function.

7.3.3.1 TABLE II Low functions valid for main functions VER A and VER B

VER A selects the vertical channel A and VER B selects the vertical channel B.

Low functions valid for main functions VER A and VER B

PM33xx	Header:	Body:	Function or response:
20A 40	FCN	ON	Selected channel ON ---> active state.
20A 40	FCN	OFF	Selected channel OFF ---> inactive state. This is only possible in dual channel mode (CHP ON).
			NOTE: If for example only one channel is active and you want to inactivate this channel (turn it off), the channel remains active.
20A 40	FCN	?	FCN ON or FCN OFF
20A 40	CHP	ON	Sets the chop function ON. Both vertical channels A and B are displayed.
20A 40	CHP	OFF	Sets the chop function OFF only channel A or B is displayed.
20A 40	CHP	?	CHP ON or CHP OFF
20A 40	INV	ON	The signal of the selected channel is inverted (before it is digitized).
20A 40	INV	OFF	The invert function is set inactive.
20A 40	INV	?	INV ON or INV OFF
20A --	MNM	ON	Selects the MIN / MAX mode.
20A --	MNM	OFF	MIN / MAX mode is switched off.
20A --	MNM	?	MNM ON or MNM OFF
20A --	BWL	ON	Sets the bandwidth filter active.
20A --	BWL	OFF	Inactivates the bandwidth filter.
20A --	BWL	?	BWL ON or BWL OFF

Low functions valid for main functions VER A and VER B

PM33xx	Header:	Body:	Function or response:
20A 40	AVG	XX	The average function is selected. Different calculation constants by using the number XX can be selected. XX is 1,2, 4, 8, 16, 32 or 64. (1 equals OFF).
20A 40	AVG	OFF	The average function is switched off.
20A 40	AVG	?	AVG XX AVG 1 means AVG OFF.
-- 40	EYE_PATTERN ON		Sets eye pattern mode on for the selected channel(s).
-- 40	EYE_PATTERN OFF		The eye pattern mode is set inactive.
-- 40	EYE_PATTERN ?		EYEPATTERN ON or EYEPATTERN OFF
-- 40	MULTSAMP	XX	The multiple sampling mode is selected. Different constants can be selected by using the number XX. XX is 1, 2, 4, 8, 16 or 32 (1 equals OFF).
-- 40	MULTSAMP	OFF	The multiple sampling mode is switched off.
-- 40	MULTSAMP	?	MULTSAMP XX MULTSAMP 1 means MULTSAMP OFF.
20A --	CPL	AC	The input coupling is set to AC. The offset is set to 0.
20A --	CPL	DC	The input coupling is set to DC. The offset is set to the previously selected offset value (when coming from AC).
20A --	CPL	ZERO	The input coupling is set to zero. The connection between the input BNC and the relevant circuit is interrupted and the input circuit is grounded.
20A --	CPL	?	CPL AC, CPL DC or CPL ZERO
20A --	IMP	HIGH	Sets the impedance of the input to 1 Mohm.
20A --	IMP	LOW	Sets the impedance of the input to 50 ohm.
			NOTE: If a probe with automatic probe indication is used, the oscilloscope automatically switches to the correct impedance. No other selection can be made then.
20A --	IMP	?	IMP HIGH or IMP LOW
20A 40	OFS	AUT	The offset value of the signal on the selected channel is set to such a level that the mid-value of the input signal is shifted as much as possible to mid-memory.
20A 40	OFS	ZERO	The offset value of the signal on the selected channel is set to zero.

Low functions valid for main functions VER A and VER B

PM33xx	Header:	Body:	Function or response:
20A --	OFS	SXX...XXESYY	The offset of the signal is set to the value represented by the number SXXXXXXXXXESYY. The range depends of the current attenuator setting of the selected channel.
-- 40	OFS	SXX...XXESYY	The offset of the signal is set to the value represented by the number SXXXXXXXXXESYY. The range lies between -1.72E+00 and +1.72E+00.
20A 40	OFS	UP	The offset of the signal is increased until the highest possible offset value is reached. The amount depends on the attenuator setting and whether an offset change of screens (UPDOWN SCREEN) or of divisions (UPDOWN DIVISIONS) is selected. The repeat factor is about 300 ms. NOTE: The OFS UP function remains active until an OFS NORMAL is sent. One single step can be programmed by: OFS UP usp OFS NORMAL where usp is the unit separator.
20A 40	OFS	DOWN	The offset of the signal is decreased until the lowest possible offset value is reached. The amount depends on the attenuator setting and whether an offset change of screens (UPDOWN SCREEN) or of divisions (UPDOWN DIVISIONS) is selected. The repeat factor is about 300 msec. NOTE: The OFS DOWN function remains active until an OFS NORMAL is sent. One single step can be programmed by: OFS DOWN usp OFS NORMAL where usp is the unit separator.
20A 40	OFS	NORMAL	Ends the automatic increase or decrease of the offset caused by a previous send OFS UP or OFS DOWN command.
20A 40	OFS	?	OFS SXXXXXXXXXESYY
20A 40	UPDOWN	SCREEN	Sets the offset change to screen value. This means that the amount of the increase or decrease for each step in the OFS UP or OFS DOWN mode is one complete screen of 10 divisions.
20A 40	UPDOWN	DIVISIONS	Sets the offset change to division value. This means that the amount of the increase or decrease for each step in the OFS UP or OFS DOWN mode is one division.

Low functions valid for main functions VER A and VER B

PM33xx	Header:	Body:	Function or response:
20A 40	UPDOWN	?	UPDOWN SCREEN or UPDOWN DIVISIONS
-- 40	ROFS	SXXXXX	The offset setting is updated to a new value by adding the relative value SXXXXX to the current value of the offset setting. The number SXXXXX can be between -32768 and +32767 where 1 step equals 10 uV.
-- 40	ROFS	?	ROFS SXXXXX
20A --	ATT	XXESYY	The input sensitivity of the selected channel can be programmed directly. The following table shows the exact syntax. Mantissa E Sign Exponent XX E S YY 50 E - 03 (Example 50 mV/div) 5E-03 (5 mV/div) 10E-03 (10 mV/div) 20E-03 (20 mV/div) 50E-03 (50 mV/div) .1E+00 (100 mV/div) .2E+00 (200 mV/div) .5E+00 (500 mV/div) 1E+00 (1 V/div) 2E+00 (2 V/div) 5E+00 (5 V/div)
-- 40	ATT	XXESYY	The input sensitivity of the selected channel can be programmed directly. The following table shows the exact syntax. Mantissa E Sign Exponent XX E S YY 50 E - 03 (Example 50 mV/div) 1E-03 (1 mV/div) not in EYEPATTERN 2E-03 (2 mV/div) not in EYEPATTERN 5E-03 (5 mV/div) 10E-03 (10 mV/div) 20E-03 (20 mV/div) 50E-03 (50 mV/div) .1E+00 (100 mV/div) .2E+00 (200 mV/div)
NOTE: If a previous ATT UP or ATT DOWN is sent to the oscilloscope, the oscilloscope will first follow the instruction ATT XXESYY and will afterwards remain in its up or down status.			

Low functions valid for main functions VER A and VER B

PM33xx	Header:	Body:	Function or response:
20A 40	ATT	UP	<p>The input sensitivity of the selected channel is increased (stepping up) until the highest possible sensitivity is reached. The repeat factor is about 300 ms.</p> <p>NOTE: The ATT UP function remains in the active state until an ATT NORMAL is sent.</p> <p>One single step can be programmed by: ATT UP usp ATT NORMAL</p> <p>where usp is the unit separator.</p>
20A 40	ATT	DOWN	<p>The input sensitivity of the selected channel is decreased (stepping down) until the lowest possible sensitivity is reached. The repeat factor is about 300 ms.</p> <p>NOTE: The ATT DOWN function remains in the active state until an ATT NORMAL is sent.</p> <p>One single step can be programmed by: ATT DOWN usp ATT NORMAL</p> <p>where usp is the unit separator.</p>
20A 40	ATT	NORMAL	<p>Ends the automatic increase or decrease of the attenuator caused by a previous send ATT UP or ATT DOWN command.</p>
20A 40	ATT	?	<p>ATT XXESYY</p> <p>NOTE: The answer represents the input sensitivity of the selected channel without the influence of a connected attenuator probe.</p>
20A --	VAR	XXX	<p>The variable gain setting of the selected channel is put in an <u>absolute</u> position represented by the number XXX. This number can be between 0 (this means, knob turned fully clockwise) and 460 (knob turned fully counter clockwise).</p>
-- 40	VAR	XXX	<p>The variable gain setting of the selected channel is put in an <u>absolute</u> position represented by the number XXX. This number can be between 0 (this means, knob turned fully anti-clockwise) and 542 (knob turned fully clockwise).</p>
20A 40	VAR	CAL	<p>The variable gain control is put in the calibrated position.</p>
20A 40	VAR	?	VAR XXXX

Low functions valid for main functions VER A and VER B

PM33xx	Header:	Body:	Function or response:
20A --	RVAR	SXXX	The variable gain setting is updated to the new gain variable by adding the <u>relative</u> value (represented by the number XXX) to the current (absolute) value of the gain control. SXXX is a value in the range -460 to +460.
-- 40	RVAR	SXXX	The variable gain setting is updated to the new gain variable by adding the <u>relative</u> value (represented by the number XXX) to the current (absolute) value of the gain control. SXXX is a value in the range -542 to +542.
20A 40	RVAR	?	Answer is always RVAR Ø
20A --	POS	XXXX	The shift position is set to the <u>absolute</u> position, represented by the number XXXX. This number XXXX can be between 0 (this means knob turned fully counter clockwise) and 1023 (knob turned clockwise).
20A --	POS	CAL	The shift is set to the fixed position (512).
20A --	POS	?	POS XXXX
20A --	RPOS	SXXXX	The shift position is updated to the new position by adding the <u>relative</u> value (represented by the number XXXX) to the current (absolute) position. SXXXX is a value in the range -1024 to +1023.
20A --	RPOS	?	Answer is always RPOS Ø
20A --	PRO	?	PRO UNKNOWN, PRO CURRENT, PRO LOW_1:10, PRO LOW_1:100, PRO HIGH_1:10, PRO HIGH_1:100 or PRO HV_ISOLATION (LOW = 50 Ohm and HIGH is 1 MOhm)
-- 40	PRO	?	PRO UNKNOWN, LOW_1:10 or LOW_1:100
20A 40	ABS_MNM	R1	Selects register R1 where result is stored.
20A 40	ABS_MNM	R2	Selects register R2 where result is stored.
20A 40	ABS_MNM	R3	Selects register R3 where result is stored.
20A 40	ABS_MNM	RUN	This command starts the absolute min max function.
20A 40	ABS_MNM	STOP	This command stops the absolute min max function.
20A 40	ABS_MNM	?	ABS_MNM RUN or ABS_MNM STOP
20A 40	ERASE	AUT	This command activates the auto erase function.
20A 40	ERASE	NO	This command switches the auto erase function off.
20A 40	ERASE	?	ERASE AUT or ERASE NO

7.3.3.2 TABLE III: Low functions valid for main function VER ADD

VER ADD selects the ADD-mode for the two vertical channels.

Low functions valid for main function VER ADD

PM33xx	Header:	Body:	Function or response:
20A 40	FCN	ON	Selected channel ON ---> active state.
20A 40	FCN	OFF	Selected channel OFF ---> inactive state.
20A 40	FCN	?	FCN ON or FCN OFF
20A --	MNM	ON	Selects the MIN / MAX mode.
20A --	MNM	OFF	MIN / MAX mode is switched off.
20A --	MNM	?	MNM ON or MNM OFF
20A --	BWL	ON	Sets the bandwidth filter active.
20A --	BWL	OFF	Inactivates the bandwidth filter.
20A --	BWL	?	BWL ON or BWL OFF
20A 40	AVG	XX	The average function is selected. Different calculation constants by using the number XX can be selected. XX is 1, 2, 4, 8, 16, 32, 64. (1 equals OFF).
20A 40	AVG	OFF	The average function is switched off.
20A 40	AVG	?	AVG XX AVG 1 means AVG OFF.
20A 40	ABS_MNM	R1	Selects register R1 where result is stored.
20A 40	ABS_MNM	R2	Selects register R2 where result is stored.
20A 40	ABS_MNM	R3	Selects register R3 where result is stored.
20A 40	ABS_MNM	RUN	This command starts the absolute min max function.
20A 40	ABS_MNM	STOP	This command stops the absolute min max function.
20A 40	ABS_MNM	?	ABS_RUN or ABS_MNM STOP
20A 40	ERASE	AUT	This command activates the auto erase function.
20A 40	ERASE	NO	This command switches the auto erase function off.
20A 40	ERASE	?	ERASE AUT or ERASE NO

Low functions valid for main function VER ADD

PM33xx	Header:	Body:	Function or response:
-- 40	MULTSAMP	XX	The multiple sampling mode is selected. Different constants can be selected by using the number XX. XX is 1, 2, 4, 8, 16 or 32 (1 equals OFF).
-- 40	MULTSAMP	OFF	The multiple sampling mode is switched off.
-- 40	MULTSAMP	?	MULTSAMP XX MULTSAMP 1 means MULTSAMP OFF.

7.3.4 Main function HORIZONTAL

HOR MTB is the only horizontal main function of the oscilloscope. The next table gives a clear overview of the available low functions per main function.

A request for the horizontal settings within this main function can be done by programming HOR ? . The answer is dependent on the previously selected main function.

7.3.4.1 TABLE IV: Low functions valid for main function HOR MTB

HOR MTB selects the horizontal main time base.

Low functions valid for main function HOR MTB

PM33xx	Header:	Body:	Function or response:
20A 40	MOD	REC	Selects the RECURRENT mode. A new signal is recorded in register R0 and refreshed each time the trigger level is passed (after a certain hold off time) and the selected trigger delay has been reached.
20A 40	MOD	SNG	The SINGLE mode is selected, and the mode is armed at the same time (SING.ARMD). The contents of R0 will be overwritten by a new signal when the trigger level is passed and the selected delay has been reached. Each new selection of this function rearms the single function shot again. Also the GET command rearms the single shot function again. Another way to arm the single shot again is to program: MSC AUX usp CLR ON usp CLR OFF where usp is the unit separator.
20A 40	MOD	MLP	The MULTIPLE mode is selected, and the mode is armed at the same time (MULT.ARMD). Four single shot signals can be recorded sequentially in R3, R2, R1 and R0 respectively. Each new selection of this function "rearms" the multiple mode again. Also the GET command rearms the multiple mode again. Another way to arm the multiple mode again, is to program: MSC AUX usp CLR ON usp CLR OFF where usp is the unit separator.
20A --	MOD	ROLL	Selects the ROLL mode. Time base speeds from 50 ms/div...360 s/div can be selected. The input signal is recorded and stored in R0.
20A --	MOD	?	MOD REC, MOD SNG, MOD MLP or MOD ROLL

Low functions valid for main function HOR MTB

PM33xx	Header:	Body:	Function or response:
-- 40	MOD	MULT_EYE	This command switches the MULTIPLE EYE PATTERN mode on.
-- 40	MOD	?	MOD REC, MOD SNG, MOD MLP or MOD MULT_EYE
20A --	RES	HIGH	Selecting the high resolution mode for the acquisition.
20A --	RES	LOW	Selecting the low resolution mode for the acquisition.
20A --	RES	?	RES HIGH or RES LOW
-- 40	RES	UP	This command switches the horizontal resolution to an increasing value: via 64, 128, 256 into 512 samples. NOTE: This function has a repeat factor of 300 ms and remains active until a RES NORMAL command is send.
-- 40	RES	DOWN	This command switches the horizontal resolution to a decreasing value: via 512, 256, 128 into 64 samples. NOTE: This function has a repeat factor of 300 ms and remains active until a RES NORMAL command is send.
-- 40	RES	NORMAL	This command stops the RES UP or the RES DOWN function.
-- 40	RES	XXX	The horizontal resolution can be adjusted to the value XXX being 512, 256, 128 or 64.
-- 40	RES	?	RES XXX XXX: 512, 256, 128 or 64.
-- 40	FAST	ON	This command switches the horizontal resolution to 64.
-- 40	FAST	OFF	This command switches the horizontal resolution to the value from before the command FAST ON.
-- 40	FAST	?	FAST ON or FAST OFF
20A 40	UPDOWN	VOLT	Selects the gap adjustment being changed in vertical sense via the REFERENCE UP or REFERENCE DOWN commands.
20A 40	UPDOWN	TIME	Selects the gap adjustment being changed in horizontal sense via the REFERENCE UP or REFERENCE DOWN commands.
20A 40	UPDOWN	?	UPDOWN VOLT, UPDOWN TIME, UPDOWN DIV or UPDOWN SCREEN
20A 40	REFERENCE	R1	Selects R1 as the register for the reference signal.

Low functions valid for main function HOR MTB

PM33xx	Header:	Body:	Function or response:
20A 40	REFERENCE	R2	Selects R2 as the register for the reference signal.
20A 40	REFERENCE	R3	Selects R3 as the register for the reference signal.
20A 40	REFERENCE	UP	Adjusts the gap of the reference signal in left-hand direction. (UPDOWN TIME) respectively in upwards direction (UPDOWN VOLT). Doesn't function if MULTIPLE or SINGLE mode is selected. NOTE: This function has a repeat factor of 300 ms and remains active until a REFERENCE NORMAL command is send.is
20A 40	REFERENCE	DOWN	Adjusts the gap of the reference signal in right-hand direction. (UPDOWN TIME) respectively in downwards direction (UPDOWN VOLT). Doesn't function if MULTIPLE or SINGLE mode is selected. NOTE: This function has a repeat factor of 300 ms and remains active until a REFERENCE NORMAL command is send.
20A 40	REFERENCE	NORMAL	This command stops the REFERENCE UP or the REFERENCE DOWN function.
20A 40	REFERENCE	RECALL	This command saves the register R \emptyset contents one time in the selected reference register.
20A 40	REFERENCE	BEGIN	Starts absolute minmax to selected reference register.
20A 40	REFERENCE	END	Stops absolute minmax to selected reference register.
20A 40	REFERENCE	?	REFERENCE R1, REFERENCE R2, REFERENCE R3, REFERENCE UP, REFERENCE DOWN, REFERENCE NORMAL, REFERENCE RECALL or REFERENCE NO
20A 40	DIFFERENCE	R1	Selects R1 as the register where the signal in DIFFERENCE SAVE mode is stored.
20A 40	DIFFERENCE	R2	Selects R2 as the register where the signal in DIFFERENCE SAVE mode is stored.
20A 40	DIFFERENCE	R3	Selects R3 as the register where the signal in DIFFERENCE SAVE mode is stored.
20A 40	DIFFERENCE	SAVE	Selects function SAVE ON DIFFERENCE.
20A 40	DIFFERENCE	STOP	Selects function STOP ON DIFFERENCE.
20A 40	DIFFERENCE	OFF	This command switches the DIFFERENCE mode off and the normal recurrent mode on.
20A 40	DIFFERENCE	?	DIFFERENCE R1, DIFFERENCE R2, DIFFERENCE R3, DIFFERENCE SAVE, DIFFERENCE STOP or DIFFERENCE OFF

Low functions valid for main function HOR MTB

PM33xx	Header:	Body:	Function or response:
20A 40	FCN	RUN	This command starts the SAVE or STOP on difference mode.
20A 40	FCN	STOP	This command stops the SAVE or STOP on difference mode.
20A 40	FCN	?	FCN RUN or FCN STOP
20A --	ROLL	RUN	Start the ROLL mode.
20A --	ROLL	STOP	Stop the ROLL mode.
20A --	ROLL	TRIGGERED	Selects the TRIGGERED roll mode. The ROLL mode is stopped by a trigger signal. The triggered stop can be delayed by selecting a trigger delay. Each new selection of this function will restart the triggered ROLL mode. The TRIGGERED roll mode can be switched off again by programming ROLL STOP.
20A --	ROLL	?	ROLL RUN, ROLL STOP or ROLL TRIGGERED
20A --	CLK	YES	Selection of an external applied sampling clock. The conversion ratio depends on the signal which is applied on the EVENTS/EXT CLOCK input. The internal TIME BASE is switched off then. NOTE: A previous selected EVENTS will be switched off.
20A --	CLK	NO	The selection of the EXTERNAL CLOCK gating is switched off.
20A --	CLK	?	CLK YES or CLK NO
20A 40	TIM	UP	The time base speed is increased, until the highest possible speed is reached. The repeat factor of this command is about 300 ms. NOTE: The TIM UP function remains active until a TIM NORMAL is sent. One single step can be programmed by: TIM UP usp TIM NORMAL where usp is the unit separator.
20A 40	TIM	DOWN	The TIME BASE speed is decreased, until the lowest possible speed is reached. The repeat factor of this command is about 300 ms. NOTE: The TIM DOWN function remains active until a TIM NORMAL is sent. One single step can be programmed by: TIM DOWN usp TIM NORMAL where usp is the unit separator.

Low functions valid for main function HOR MTB

PM33xx	Header:	Body:	Function or response:																																		
-- 40	TIM	XXESYY	<p>The time base speed can be programmed directly via the following table which shows the exact.</p> <p>Mantissa E Sign Exponent</p> <table> <tr> <td>XX</td> <td>E S</td> <td>YY</td> </tr> <tr> <td>50</td> <td>E -</td> <td>09 (Example 50 ns/div)</td> </tr> </table> <p>Recurrent ROLL</p> <table> <tr><td>1E-09</td><td>(1 ns/div)</td></tr> <tr><td>2E-09</td><td>(2 ns/div)</td></tr> <tr><td>5E-09</td><td>(5 ns/div)</td></tr> <tr><td>10E-09</td><td>(10 ns/div)</td></tr> <tr><td>20E-09</td><td>(20 ns/div)</td></tr> <tr><td>50E-09</td><td>(50 ns/div)</td></tr> <tr><td>.1E-06</td><td>(100 ns/div)</td></tr> <tr><td>.2E-06</td><td>(200 ns/div)</td></tr> <tr><td>.5E-06</td><td>(500 ns/div)</td></tr> <tr><td>1E-06</td><td>(1 us/div)</td></tr> <tr><td>2E-06</td><td>(2 us/div)</td></tr> <tr><td>5E-06</td><td>(5 us/div)</td></tr> <tr><td>10E-06</td><td>(10 us/div)</td></tr> <tr><td>20E-06</td><td>(20 us/div)</td></tr> </table> <p>NOTE: If a previous TIM UP or TIM DOWN is sent to the oscilloscope, the oscilloscope will first follow the instruction TIM XXESYY and will afterwards remain in its up or down status.</p>	XX	E S	YY	50	E -	09 (Example 50 ns/div)	1E-09	(1 ns/div)	2E-09	(2 ns/div)	5E-09	(5 ns/div)	10E-09	(10 ns/div)	20E-09	(20 ns/div)	50E-09	(50 ns/div)	.1E-06	(100 ns/div)	.2E-06	(200 ns/div)	.5E-06	(500 ns/div)	1E-06	(1 us/div)	2E-06	(2 us/div)	5E-06	(5 us/div)	10E-06	(10 us/div)	20E-06	(20 us/div)
XX	E S	YY																																			
50	E -	09 (Example 50 ns/div)																																			
1E-09	(1 ns/div)																																				
2E-09	(2 ns/div)																																				
5E-09	(5 ns/div)																																				
10E-09	(10 ns/div)																																				
20E-09	(20 ns/div)																																				
50E-09	(50 ns/div)																																				
.1E-06	(100 ns/div)																																				
.2E-06	(200 ns/div)																																				
.5E-06	(500 ns/div)																																				
1E-06	(1 us/div)																																				
2E-06	(2 us/div)																																				
5E-06	(5 us/div)																																				
10E-06	(10 us/div)																																				
20E-06	(20 us/div)																																				
20A 40	TIM	?	<p>TIM XXESYY</p> <p>NOTE: The answer from the oscilloscope represents the time base speed, without the influence of the selected expand factor.</p>																																		
-- 40	MGN	XX	<p>The magnifier in the instruments horizontal section is set to the value XX by this command. Possible values for XX are 1, 2, 5, 10, 20 and 50.</p>																																		
-- 40	MGN	?	<p>MGN XX</p> <p>XX: 1, 2, 5, 10, 20 or 50.</p>																																		
20A 40	TSO	A	Channel A is selected as trigger source.																																		
20A 40	TSO	B	Channel B is selected as trigger source.																																		
20A 40	TSO	EXT	The EXT TRIG input signal is selected as trigger source.																																		
20A --	TSO	EXD	The EXT TRIG input signal is selected as trigger source and attenuated 10 times.																																		
20A --	TSO	LINE	The line signal derived from the mains supply is used as trigger signal.																																		

Low functions valid for main function HOR MTB

PM33xx	Header:	Body:	Function or response:
20A --	TSO	?	TSO A, TSO B, TSO EXT, TSO EXD or TSO LINE
-- 40	TSO	?	TSO A, TSO B or TSO EXT
-- 40	SENSITIVITY LOW		This command selects low sensitivity for the triggering.
-- 40	SENSITIVITY HIGH		This command selects high sensitivity for the triggering.
-- 40	SENSITIVITY ?		SENSITIVITY LOW or SENSITIVITY HIGH
20A 40	TSL	POS	The time base system or the external clock system is triggered on the positive going edge of the trigger signal.
20A 40	TSL	NEG	The time base system or the external clock system is triggered on the negative going edge of the trigger signal.
20A 40	TSL	?	TSL POS or TSL NEG
20A --	DUA	ON	Dual triggering is selected. The instrument will trigger on the negative as well as the positive going slope of the trigger signal.
20A --	DUA	OFF	Dual triggering is switched off. NOTE: Dual triggering is not possible in the time base range 100 ns/div ... 5 ns/div.
20A --	DUA	?	DUA ON or DUA OFF
20A --	CPL	AC	The coupling of the trigger signal is set to AC.
20A --	CPL	DC	The coupling of the trigger signal is set to DC.
20A --	CPL	AUT	The trigger level setting is limited between the highest and the lowest level of the signal (AUTO), the trigger coupling is AC.
20A --	CPL	LFAC	The trigger signal is AC coupled with an LF pass. AC + HFreject is selected.
20A --	CPL	HFAC	The trigger signal is AC coupled with an HF pass. AC + LFreject is selected.
20A --	CPL	LFDC	The trigger signal is DC coupled with an LF pass. DC + HFreject is selected.
20A --	CPL	LFAUT	The trigger signal is AUTO coupled (AC) with an LF pass. AUTO + HFreject is selected.
20A --	CPL	HFAUT	The trigger signal is AUTO coupled (AC) with an HF pass. AUTO + LFreject is selected.

Low functions valid for main function HOR MTB

PM33xx	Header:	Body:	Function or response:
20A --	CPL	TVF	The trigger signal is synchronized to a television frame signal for the CCIR system 625/525 lines.
20A --	CPL	?	CPL AC, CPL DC, CPL AUT, CPL LFAC, CPL HFAC, CPL LFDC, CPL LFAUT, CPL HFAUT or CPL TVF
-- 40	CPL	TRI	This command switches instrument to the TRIGGER MODE.
-- 40	CPL	SYNC	This command switches instrument to the SYNCHRONIZE MODE.
-- 40	CPL	COUNTDOWN	This command switches the instrument to the COUNTDOWN MODE.
-- 40	CPL	AUT	This command switches the instrument to the AUTO SELECT MODE.
-- 40	CPL	?	CPL TRI, CPL SYNC, CPL COUNTDOWN or CPL AUT NOTE: In AUTO SELECT MODE, the answer is CPL AUT and not the trigger mode that is selected by the system. This mode can be trigger, synchronize or countdown.
20A --	TRD	TIME	Selects the trigger delay in seconds.
20A --	TRD	DIVISIONS	Selects the trigger delay in divisions.
20A --	TRD	ZERO	Sets the trigger delay to zero.
20A --	TRD	SXXXX	The trigger delay (DIV or EVENTS) is set to the value SXXXX. SXXXX is a value in the range -10 to +9999. NOTE: Programming a TRD SXXXX will automatically select a display in DIV when coming from TIME.
20A --	TRD	SXX...XXESYY	The trigger delay can be set to the value represented by the number SXXXXXXXXXESYY, where SXXXXXXXXXESYY is the trigger delay expressed in time. NOTE: Programming a TRD SXXXXXXXXXESYY will automatically select a display in TIME when coming from DIV.
20A --	TRD	UP	The trigger delay is increased until the highest possible value is reached. When TIME or DIV is selected, the amount depends on whether a stepsize of screens (UPDOWN SCREEN) or of divisions (UPDOWN DIVISIONS) is selected. The repeat factor is about 300 msec. NOTE: The TRD UP function remains active until a TRD NORMAL is sent. One single step can be programmed by: TRD UP usp TRD NORMAL where usp is the unit separator.

Low functions valid for main function HOR MTB

PM33xx	Header:	Body:	Function or response:
20A --	TRD	DOWN	<p>The trigger delay is decreased until the lowest possible value is reached. When TIME or DIV is selected, the amount depends on whether a stepsize of screens (UPDOWN SCREEN) or of divisions (UPDOWN DIVISIONS) is selected.</p> <p>NOTE: The TRD DOWN function remains active until a TRD NORMAL is sent.</p> <p>One single step can be programmed by: TRD DOWN usp TRD NORMAL where usp is the unit separator.</p>
20A --	TRD	NORMAL	<p>Ends the automatic increase or decrease of the trigger delay, caused by a previous send TRD UP or TRD DOWN command.</p>
20A --	TRD	?	TRD SXXXX (div) or TRD SXXXXXXXXXXESYY (time)
-- 40	TRD	SXXXX	<p>The trigger delay can be adjusted to the number of divisions represented by the number SXXXX. The range of number SXXXX depends on time base sweep speed and magnifier position: for exact figures refer to the oscilloscope's specification.</p>
-- 40	TRD	ZERO	<p>This command sets the trigger delay to 0 divisions.</p>
-- 40	TRD	UP	<p>The trigger delay is increased until the highest possible value is reached. The increase is in steps of 1 division (UPDOWN DIV active) or in steps of 10 divisions (UPDOWN SCREEN active). The repeat factor is about 300 msec.</p> <p>NOTE: The TRD UP function remains active until a TRD NORMAL is sent.</p> <p>One single step can be programmed by: TRD UP usp TRD NORMAL where usp is the unit separator.</p>
-- 40	TRD	DOWN	<p>The trigger delay is decreased until the lowest possible value is reached. The decrease is in steps of 1 division (UPDOWN DIV active) or in steps of 10 divisions (UPDOWN SCREEN active). The repeat factor is about 300 msec.</p> <p>NOTE: The TRD DOWN function remains active until a TRD NORMAL is sent.</p> <p>One single step can be programmed by: TRD DOWN usp TRD NORMAL where usp is the unit separator.</p>

Low functions valid for main function HOR MTB

PM33xx	Header:	Body:	Function or response:
-- 40	TRD	NORMAL	Ends the automatic increase or decrease of the trigger delay, caused by a previous send TRD UP or TRD DOWN command.
-- 40	TRD	?	TRD SXXXX (div)
20A 40	UPDOWN	DIVISIONS	The trigger delay changes in steps of 1 division if command TRD UP or TRD DOWN is active.
20A 40	UPDOWN	SCREEN	The trigger delay changes in steps of 10 divisions if command TRD UP or TRD DOWN is active.
20A 40	UPDOWN	?	UPDOWN DIVISIONS, UPDOWN SCREEN, UPDOWN VOLT or UPDOWN TIME
20A --	EVT	ON	This command switches EVENTS mode on. Also DELAY is functioning in this mode.
20A --	EVT	OFF	This command switches EVENTS mode off.
20A --	EVT	ZERO	This command resets EVENTS into EVENTS = 1.
20A --	EVT	UP	The EVENTS value is increased until the highest possible value is reached. The repeat factor is about 300 ms. NOTE: The EVT UP function remains active until a EVT NORMAL is sent. One single step can be programmed by: EVT UP usp EVT NORMAL where usp is the unit separator.
20A --	EVT	DOWN	The EVENTS value is decreased until the lowest possible value is reached. The repeat factor is about 300 ms. NOTE: The EVT DOWN function remains active until a EVT NORMAL is sent. One single step can be programmed by: EVT DOWN usp EVT NORMAL where usp is the unit separator.
20A --	EVT	NORMAL	Ends the automatic increase or decrease of the number of EVENTS caused by a previous send EVT UP or EVT DOWN command.
20A --	EVT	XXXX	The number of EVENTS is set to XXXX. XXXX is a value in the range 1 to 9999.
20A --	EVT	?	EVT XXXX

Low functions valid for main function HOR MTB

PM33xx	Header:	Body:	Function or response:
20A --	LEV	XXX	The trigger level is set to the absolute value, represented by the number XXX. This number can be between 0 and 511. IF a previous LEV VAR is sent, the value is for the EVENT leveling, otherwise the value is for the trigger level itself.
20A --	LEV	TTL	The trigger level of the EVENTS/EXT CLOCK input is set for TTL signals.
20A --	LEV	ECL	The trigger level of the EVENTS/EXT CLOCK input is set for ECL signals.
20A --	LEV	VAR	The trigger level of the EVENTS/EXT CLOCK input is set for manual and/or remote controlled level control. NOTE: The trigger levels for EVENTS/EXT clock are only set if you are in the COUPLING EV/EXT CLK menu (this menu can be programmed by programming MSC AUX/MENU 22). NOTE: After programming LEV VAR, the LEV XXX command will vary the level of trigger of the EVENTS/EXT CLOCK input otherwise the LEV XXX will vary the normal trigger level.
20A --	LEV	?	If menu COUPLING EV/EXT CLK is selected and the EVENTS LEVEL is set to TTL (LEV TTL) the answer is: LEV TTL If menu COUPLING EV/EXT CLK is selected and the EVENTS LEVEL is set to ECL (LEV ECL) the answer is: LEV ECL If menu COUPLING EV/EXT CLK is selected and the EVENTS LEVEL is set to VAR (LEV VAR) the answer is: LEV XXX XXX is a value in the range 0 to 511. If menu COUPLING EV/EXT CLK was not selected, the answer is always the actual trigger level: LEV XXX XXX is a value in the range 0 to 511.
-- 40	LEV	XXX	The trigger level is set to the absolute value XXX. XXX is a value in the range 1 to 511.
-- 40	LEV	?	LEV XXX

Low functions valid for main function HOR MTB

PM33xx	Header:	Body:	Function or response:
20A 40	RLEV	SXXX	The trigger level is updated to the new level by adding the <u>relative</u> value (represented by the number SXXX) to the current (absolute) position. SXXX is a value in the range -512 to +511.
20A 40	RLEV	?	Answer is always RLEV 0
-- 40	HLO	XXX	The hold off is set to the absolute value XXX. XXX is a value in the range 0 to 511.
-- 40	HLO	?	HLO XXX
-- 40	RHLO	SXXX	The hold off position is updated to the new position by adding the <u>relative</u> value (represented by the number XXXX) to the current (absolute) position. SXXX is a value in the range -512 to +511.
-- 40	RHLO	?	Answer is always RHLO 0

7.3.5 Main function MISCELLANEOUS

MSC AUX, MSC RØ, MSC R1, MSC R2, MSC R3 and MSC TRACE are the miscellaneous main functions of the oscilloscope. The next table gives a clear overview of the available low functions per main function.

A request for the miscellaneous settings within a main function can be done by programming MSC ? . The answer is dependent on the previously selected main function. The answers of MSC TRACE are only given if the previously selected main function was MSC TRACE.

7.3.5.1 TABLE V: Low functions valid for main function MSC AUX

MSC AUX selects the miscellaneous auxiliary functions.

Low functions valid for main function MSC AUX

PM33xx	Header:	Body:	Function or response:
20A 40	WRT	ON	The register contents can be changed This is the same function as LCK OFF.
20A 40	WRT	OFF	The register contents is locked. This is the same function as LCK ON.
20A 40	WRT	?	WRT ON or WRT OFF
20A 40	LCK	ON	The register contents is locked. This is the same function as WRT OFF.
20A 40	LCK	OFF	The register contents can be changed. This is the same function as WRT ON.
20A 40	LCK	?	LCK ON or LCK OFF
20A 40	CLR	ON	Clear the register RØ until the function CLR OFF or LCK OFF or WRT ON is programmed.
20A 40	CLR	OFF	Stop clearing register RØ.
20A 40	CLR	?	CLR ON or CLR OFF
20A 40	DSP	ALL	The display of all four registers is switched on. Identical to DSP ON.
20A 40	DSP	ON	The display of all four registers is switched on. Identical to DSP ALL.
20A 40	DSP	OFF	The display of all registers is switched off except for the display of register RØ which remains always on.
20A 40	DSP	?	DSP ON or DSP ALL
20A 40	DOT	ON	Display of only dots.
20A 40	DOT	OFF	Display of dot join.
20A 40	DOT	SMT	Smoothed display.
20A 40	DOT	?	DOT ON, DOT OFF or DOT SMT

Low functions valid for main function MSC AUX

PM33xx	Header:	Body:	Function or response:
20A 40	XVAR	XXX	The variable gain setting of the horizontal channel is put in an <u>absolute</u> position represented by the number XXX. This number can be between 0 (this means, knob turned fully clockwise) and 255 (knob turned fully counter clockwise).
20A 40	XVAR	?	XVAR XXX
20A 40	RXVAR	SXXX	The variable horizontal gain setting is updated to the new gain variable by adding the <u>relative</u> value (represented by the number SXXX) to the current (absolute) value of horizontal gain control. SXXX is a value in the range -255 to +256.
20A 40	RXVAR	?	Answer is always RXVAR 0
20A 40	POS	RX	The position controls can be assigned to one of the four registers. RX is R0, R1, R2 or R3.
20A 40	POS	CAL	All position controls are set in their calibrated positions.
20A 40	POS	ALL	The X-POSITION and X-EXPAND controls are assigned to all four registers.
20A 40	POS	?	POS RX RX is register R0, R1, R2 or R3.
20A 40	EXP	X	Vertical expansion. X means: 1 = Y*1 2 = Y*5 3 = Y/5
20A 40	EXP	?	EXP 1 or EXP 2 or EXP 3
20A 40	MGN	X	Horizontal magnification. X means: 1 = *1 16 = *16 2 = *2 32 = *32 4 = *4 64 = *64 8 = *8
20A 40	MGN	?	MGN X
20A 40	XPOS	SXXXX	The X-POSITION of the selected register is set to the absolute value, represented by the number SXXXX. SXXXX is a value in the range -2048 to +2047.
20A 40	XPOS	?	XPOS SXXXX

Low functions valid for main function MSC AUX

PM33xx	Header:	Body:	Function or response:
20A 40	RXPOS	SXXXX	The variable horizontal position setting is updated to the new position variable by adding the <u>relative</u> value (represented by the number SXXXX) to the current (absolute) value of horizontal position control. SXXXX is a value in the range -4095 and +4095.
20A 40	RXPOS	?	Answer is always RXPOS 0
20A 40	FULL	ON	Full front text is switched on.
20A 40	FULL	OFF	Full front text is switched off.
20A 40	FULL	RESULTS	Selects separated cursor readout and pass/fail message in bottom text area.
20A 40	FULL	?	FULL ON, FULL OFF or FULL RESULTS
20A 40	ERROR	?	ERROR XX <ERROR TEXT> XX is the number of the current error and <ERROR TEXT> is the text belonging to this specific error.
20A 40	CHAN_ID	ON	Switches channel identification on.
20A 40	CHAN_ID	ON	Switches channel identification on.
20A 40	CHAN_ID	?	CHAN_ID ON or CHAN_ID OFF

7.3.5.2 TABLE VI: Low functions valid for main functions MSC R0, MSC R1, MSC R2 and MSC R3

MSC R.. selects the miscellaneous register functions.

Low functions valid for main function MSC R..

PM33xx	Header:	Body:	Function or response:
20A 40	DSP	ON	The display of the selected register is switched on.
20A 40	DSP	OFF	The display of the selected register is switched off. In the case that the selected register is the only one which is displayed the display remains on.
20A 40	DSP	?	DSP OFF or DSP ON
20A 40	SEL	A	Assign the Y-POSITION, the X-POSITION and the X-EXPAND control to the A channel of the selected register.
20A 40	SEL	B	Assign the Y-POSITION, the X-POSITION and the X-EXPAND control to the B channel of the selected register.
20A 40	SEL	ALL	Assign the Y-POSITION, the X-POSITION and the X-EXPAND control to the A as well as the B channel of the selected register.
20A 40	SEL	?	SEL A, SEL B or SEL ALL
20A 40	POS	CAL	If SEL A or SEL B is selected, the Y-POS of channel A or B is corrected to the calibrated position.
20A 40	POS	?	Answer is always POS CAL
20A 40	INV	ON	The contents of the selected register is inverted displayed.
20A 40	INV	OFF	The invert function is set inactive.
20A 40	INV	?	INV ON or INV OFF
20A 40	SAV	ON	This function is not available for MSC R0. Save the contents of R0 in the selected register. This function remains active until a SAV OFF is send.
20A 40	SAV	OFF	The save function, which is activated with SAV ON, is switched off.
20A 40	SAV	?	SAV ON or SAV OFF
20A 40	YVX	ON	Display of vertical channel versus vertical channel (A VERSUS B). This can only be programmed in DUAL channel mode.
20A 40	YVX	OFF	Display of vertical channel versus time axes (X=t).
20A 40	YVX	?	YVX ON or YVX OFF

Low functions valid for main function MSC R..

PM33xx	Header:	Body:	Function or response:
20A 40	YVT	ON	Display of vertical channel versus time axes (X=t).
20A 40	YVT	OFF	Display of vertical channel versus vertical channel (A VERSUS B). This can only be programmed in DUAL channel mode.
20A 40	YVT	?	YVT ON or YVT OFF
20A 40	XPOS	XXXX	The X-POSITION of the selected register is set to the <u>absolute</u> value XXXX. XXXX is a value in the range -2048 to +2047.
20A 40	XPOS	?	XPOS XXXX
20A 40	RXPOS	SXXXX	The variable horizontal position setting is updated to the new position variable by adding the <u>relative</u> value (represented by the number SXXXX) to the current (absolute) value of horizontal position control. SXXXX is a value in the range -4096 to +4095.
20A 40	RXPOS	?	Answer is always RXPOS \emptyset
20A 40	YPOS	SXXXX	The Y-POSITION of the selected register is set to the <u>absolute</u> value, represented by the number SXXXX. SXXXX is a value in the range -1024 to +1023.
20A 40	YPOS	?	YPOS SXXXX
20A 40	RYPOS	SXXXX	The variable vertical position setting is updated to the new position variable by adding the relative value (represented by the number SXXXX) to the current (absolute) value of the vertical position control. SXXXX is a value in the range -2048 and +2047.
20A 40	RYPOS	?	Answer is always RYPOS \emptyset
20A 40	XVAR	XXX	The variable gain setting of the horizontal channel is put in an <u>absolute</u> position represented by the number XXX. This number can be between 0 (this means, knob turned fully counter clockwise) and 255 (knob turned fully clockwise).
20A 40	XVAR	?	XVAR XXX

Low functions valid for main function MSC R..

PM33xx	Header:	Body:	Function or response:
20A 40	RXVAR	SXXX	The variable horizontal gain setting is updated to the new gain variable by adding the <u>relative</u> value (represented by the number SXXX) to the current (absolute) value of horizontal gain control. SXXX is a value in the range -256 to +255.
20A 40	RXVAR	?	Answer is always RXVAR 0
20A 40	REDUCED	ON	Selection of reduced text display for the selected register. (Only possible in Y/5 mode).
20A 40	REDUCED	OFF	Switches the reduced text display for the selected register off.
20A 40	REDUCED	?	REDUCED ON or REDUCED OFF
20A 40	FULL	ON	Selection of full text display for the selected register. If full text was already displayed for another register, that text is now replaced.
20A 40	FULL	OFF	Switches the full text display off.
20A 40	FULL	?	FULL ON or FULL OFF
20A 40	PENUP	0	Selection of a low level TTL signal on the penlift output.
20A 40	PENUP	1	Selection of a high level TTL signal on the penlift output.
20A 40	PENUP	?	PENUP 0 or PENUP 1

Low functions valid for main function MSC R..

PRINTING AND PLOTTING

=====

NOTES: When printing or plotting, the oscilloscope must be in LOCAL mode.

A PRINTER or PLOTTER medium has to be selected manually before using print or plot commands in the DIGITAL SELECT menu.

Controlling via IEEE and printing or plotting via RS232 (or v.v.) may cause some communication hang-ups when during printing or plotting commands are sent to your oscilloscope.

Please wait until the printer or plotter activity is completely finished.

PM33xx	Header:	Body:	Function or response:
20A 40	PLOTTIME	XXXX	The analog-plot time can be set in ms/dot. XXXX is a value between 20 and 2000.
20A 40	PLOTTIME	UP	The analog-plot-time per dot is increased in steps until the highest possible plottime is reached. The repeat factor is about 300 ms. NOTE: The analog PLOTTIME UP function remains active until a PLOTTIME NORMAL is sent. One single step can be programmed by: PLOTTIME UP usp PLOTTIME NORMAL where usp is the unit separator.
20A 40	PLOTTIME	DOWN	The analog-plot-time per dot is decreased in steps until the lowest possible analog-plot-time is reached. The repeat factor is about 300 ms. NOTE: The analog PLOTTIME DOWN function remains active until a PLOTTIME NORMAL is sent. One single step can be programmed by: PLOTTIME DOWN usp PLOTTIME NORMAL where usp is the unit separator.
20A 40	PLOTTIME	NORMAL	Ends the automatic increase or decrease of the analog-plot-time per dot caused by a previous send PLOTTIME UP or PLOTTIME DOWN command.
20A 40	PLOTTIME	?	PLOTTIME XXXX XXXX is the selected analog-plot-time per dot in ms.
20A 40	PLOTSIZE	XXX	Selection of the digital-plot-size factor. XXX is a value in the range 0.5 to 2.0.
20A 40	PLOTSIZE	?	PLOTSIZE XXX

Low functions valid for main function MSC R..

PM33xx	Header:	Body:	Function or response:
20A 40	PLOTTER	C...C	Selection of the plotter-type. C...C is PM8153_1, PM8153_6, PM8154, PM8155, HP7475A or HP7550.
20A 40	PLOTTER	?	PLOTTER C...C
20A 40	PRINTER	C...C	Selection of the printer-type. C...C is FX80 or HP2225
20A 40	PRINTER	?	PRINTER C...C
20A 40	PLT	PRINTER	Start of a register print action of the currently selected register. MSC R1 usp PLT PRINTER results in a print of register R1.
20A 40	PLT	PLOTTER	Start of a register plot action of the currently selected register. MSC R1 usp PLT PLOTTER results in a plot of register R1.
20A 40	PLT	RX	One of the registers can be selected for the plot or print action. RX is R0, R1, R2 or R3. Only possible if the selected register is also selected to be displayed.
20A 40	PLT	AUT	Selection of the AUTO PLOT function. This function can only be selected for MSC R0 when MTB HOR usp MOD SNG is selected before. After the selection of PLT AUT, PLT ANALOG or PLT DIGITAL has to be selected to start the plot or print action.
20A 40	PLT	ANALOG	Start of an analog registerplot action.
20A 40	PLT	DIGITAL	Start of a digital registerplot or print action.
20A 40	PLT	OFF	The current registerplot or print action is stopped.
20A 40	PLT	?	If the oscilloscope is performing a plot or print action the answer is: PLT ANALOG or PLT DIGITAL otherwise the answer is the selected register: R0, R1, R2 or R3
20A 40	SCREENPLOT	ANALOG	Start of an analog screenplot action.
20A 40	SCREENPLOT	DIGITAL	Start of a digital screenplot or print action.
20A 40	SCREENPLOT	OFF	The current screenplot or print action is stopped.
20A 40	SCREENPLOT	?	SCREENPLOT ANALOG or SCREENPLOT DIGITAL

Low functions valid for main function MSC R..

PM33xx	Header:	Body:	Function or response:
20A 40	GRID	X	X = 0 for selection of a complete grid consisting of borderlines and vertical and horizontal gridlines. X = 1 for selection of a grid consisting of borderlines and centre vertical and horizontal gridlines. X = 2 for selection of only borderlines. X = 3 for selection of no grid. NOTE: This function can be selected for plot as well as print actions.
20A 40	GRID	?	GRID 0, GRID 1, GRID 2 or GRID 3
20A 40	QUADRANT	LEFT_TOP	Selection of the position of the plot to be made on the selected plotter medium.
20A 40	QUADRANT	RIGHT_TOP	Selection of the position of the plot to be made on the selected plotter medium.
20A 40	QUADRANT	LEFT_BOTTOM	Selection of the position of the plot to be made on the selected plotter medium.
20A 40	QUADRANT	RIGHT_BOTTOM	Selection of the position of the plot to be made on the selected plotter medium.
20A 40	QUADRANT	?	QUADRANT LEFT_TOP, QUADRANT RIGHT_TOP QUADRANT LEFT_BOTTOM or QUADRANT RIGHT_BOTTOM
20A 40	FULL	ON	Full register text is switched on.
20A 40	FULL	OFF	Full register text is switched off.
20A 40	FULL	?	FULL ON or FULL OFF

7.3.5.3 TABLE VII: Low functions valid for main function MSC TRACE

This main function can only be selected after the selection of the required register via super function REG X.

MSC TRACE selects the trace data transfer functions.

After programming MSC TRACE first INTF has to be selected.

Low functions valid for main function MSC TRACE

PM33xx	Header:	Body:	Function or response:
20A 40	INTF	IEEE488.Ø	Selects the IEEE interface and uses the interface parameters bsp, usp, spr and the IEEE settings as defined under SPL INTERFACE, INTF IEEE488.Ø, BSP,... etc.
20A 40	INTF	RS232_IN.Ø	Selects the RS232 interface for data input and uses the interface parameters bsp, usp, spr and the RS232_IN settings as defined under SPL INTERFACE, INTF RS232_IN.Ø, BSP,... etc.
20A 40	INTF	RS232_OUT.Ø	Selects the RS232 interface for data output and uses the interface parameters bsp, usp, spr and the RS232_OUT settings as defined under SPL INTERFACE, INTF RS232_OUT.Ø, BSP,... etc.
20A 40	INTF	?	INTF UNKNOWN, IEEE488.Ø or RS232_IN.Ø or RS232_OUT.Ø INTF UNKNOWN is the default POWER ON setting.
<u>NOTE :</u>			
The instrument will automatically select the correct RS232 interface, when data is received or sent via the RS232C bus.			
20A 40	PRT	ALL	Selects <u>all</u> samples (which belong to the selected channel(s)) in the register for data transfer.
20A 40	PRT	REAL	Selects only the <u>real</u> samples (which belong to the selected channel(s)) in the register for data transfer. The oscilloscope will always start the transfer by sending DAT followed by the number of samples which can be expected to be transferred.
20A 40	PRT	?	PRT ALL or PRT REAL
20A 40	CHANNEL	A	Selection of channel A for data transfer.
20A 40	CHANNEL	B	Selection of channel B for data transfer.
20A 40	CHANNEL	ALL	Selection of the complete register contents for data transfer.
20A 40	CHANNEL	?	CHANNEL A, CHANNEL B or CHANNEL ALL

Low functions valid for main function MSC TRACE

PM33xx	Header:	Body:	Function or response:
20A 40	BGN	XXXX	Selection of the register begin address for data transfer. XXXX is a value in the range 0 to 4094.
20A 40	BGN	?	BGN XXXX
20A 40	END	XXXX	Selection of the register end address for data transfer. XXXX is a value in the range 1 to 4095.
20A 40	END	?	END XXXX
20A 40	REPEAT	XX	Repeats a data transfer XX times. This command is only effective after a DAT ? or a DAT ... command. The following selections are automatically done: DATA_TYPE BINARY PRT ALL CHANNEL ALL BGN 0 END 4095 CNT 1 When a repeat factor is selected, the oscilloscope responds to a DAT ? command with the following string (only the parts between quote marks): "DAT " followed by XX-1 times: "4096 bsp #B<H><L><H><L>...<H><L><C> bsp" followed by: "4096 bsp #B<H><L><H><L>...<H><L><C> spr" See also description of DATA_TYPE BINARY. After sending DAT ... using DATA_TYPE BINARY via the RS232C interface, you have to wait 100 ms before sending data, otherwise data may get lost. This is valid for normal and repeated transfers.
20A 40	REPEAT	OFF	Switches the repeat function off.
20A 40	REPEAT	?	REPEAT XX
20A 40	CNT	XXXX	Selection of the count (or resolution) factor for data transfer. X = 0 : is not allowed. X = 1 : all points selected. X = 2 : every second point is selected Etc.
20A 40	CNT	?	CNT XXXX

Low functions valid for main function MSC TRACE

PM33xx	Header:	Body:	Function or response:
20A 40	DATA_TYPE	DECIMAL	<p>Selection of data transfer in decimal values. These decimal values are separated from each other by block separators. The string is terminated by a separator.</p> <p>Format:</p> <p>DAT YYYY bsp SXXX bsp SXXX SXXX spr</p> <p>where YYYY is the number of decimal values to be transferred and XXXX is a decimal value between -512 and +511 in the selected data type. bsp is a block separator and spr is a separator.</p>
20A 40	DATA_TYPE	BINARY	<p>Selection of data transfer in binary values.</p> <p>Format:</p> <p>DAT Y bsp #B<H><L><H><L>...<H><L><C> spr</p> <p>Y = the number of data words to be transferred.</p> <p>The first high and low byte (H = high byte and L = low byte) combination after #B contains the number of bytes to be transferred in binary notation (this is two times the number of data words to be transferred). Then follow a number of combinations of high and low bytes each containing a data word. The last byte C contains a checksum byte which is calculated over all data bytes except the two length bytes which are transferred after #B.</p> <p>Each data word is a two's complement integer.</p>
20A 40	DATA_TYPE	?	DATA_TYPE DECIMAL or DATA_TYPE BINARY
20A 40	DAT	<p>Transfer data to the oscilloscope.</p> <p>The format of the string to be sent has to be the same as described under DATA_TYPE DECIMAL and under DATA_TYPE BINARY.</p>
20A 40	DAT	?	<p>Request for data (of the selected register) from the oscilloscope.</p> <p>The format of the answer is the same as described under DATA_TYPE DECIMAL and under DATA_TYPE BINARY.</p>

Data transfer

Each register consists of 4096 datawords of 16 bit each. A dataword may contain a real sample or a sample which is obtained by interpolation.

The table below gives a survey of the number of real samples in a register, depending on the resolution. Each sample is represented by one dataword in a trace register.

Mode	Active in	Real samples/ch.
High resolution	PM3320A in high resolution	single channel 4096 dual channel 2048
Low resolution	PM3320A in low resolution PM3340 in RES=512	single channel 512 dual channel 512
Low resolution	PM3340 in RES=256	single channel 256 dual channel 256
Low resolution	PM3340 in RES=128	single channel 128 dual channel 128
Low resolution	PM3340 in RES=64	single channel 64 dual channel 64

The position of the datapoints in a trace register is illustrated below. Real samples are indicated in uppercase, while interpolated samples are in lower case.

Single channel

High resolution

A	A	A	A	A	A	A	A	A	A	A	
0	1	2	3	4	5	6	7	8	9	10	

Single channel

Low resolution
512 samples

A	a	a	a	a	a	a	a	a	A	a	a	
0	1	2	3	4	5	6	7	8	9	10		

Single channel

Low resolution
256 samples

A	a	a	a	a	a	a	a	a	a	a	
0	1	2	3	4	5	6	7	8	9	10	

a	a	a	a	a	A	a	a	a	a	
11	12	13	14	15	16	17	18	19	20	

Dual channel

High resolution

A	B	A	B	A	B	A	B	A	B	A
0	1	2	3	4	5	6	7	8	9	10

Dual channel

Low resolution
512 samples

A	B	a	b	a	b	a	b	A	B	a
0	1	2	3	4	5	6	7	8	9	10

Dual channel

Low resolution
256 samples

A	B	a	b	a	b	a	b	a	b	a
0	1	2	3	4	5	6	7	8	9	10

b	a	b	a	b	A	B	a	b	a
11	12	13	14	15	16	17	18	19	20

Register contents versus display:

Vertical

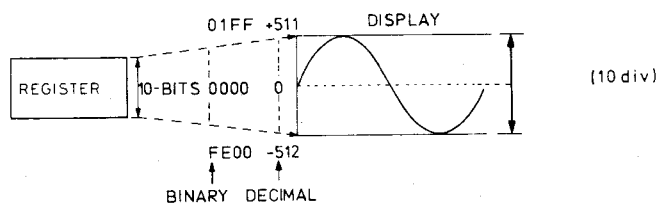

MAT 2853

Horizontal

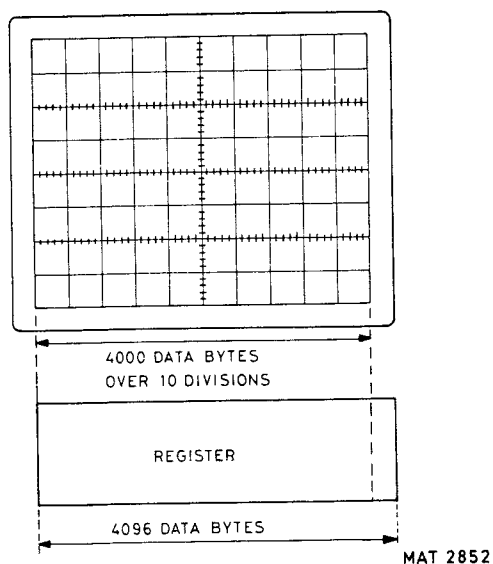

MAT 2852

Figure 7.1 Register contents versus display.

The number of datawords that is transmitted or received by the oscilloscope during a data transfer depends on 7 variables:

- PRT selection
- CHANNEL selection
- Resolution of the register
- Register type (single or dual channel)
- CNT value
- BGN value
- END value.

It is assumed that the REPEAT function is not used.

A way to look at these values is in 3 layers or sieves. The first layer determines which datawords are selected by the PRT selection, the CHANNEL selection, the resolution of the register and the register type. The second layer reduces this number of datawords by setting a low and a high limit, depending on the BEGIN and END value. The last layer reduces the number of datawords by selecting a number of datawords from the second layer by using modulo counting. This is of course dependent on the CNT value.

The diagram below illustrates this.

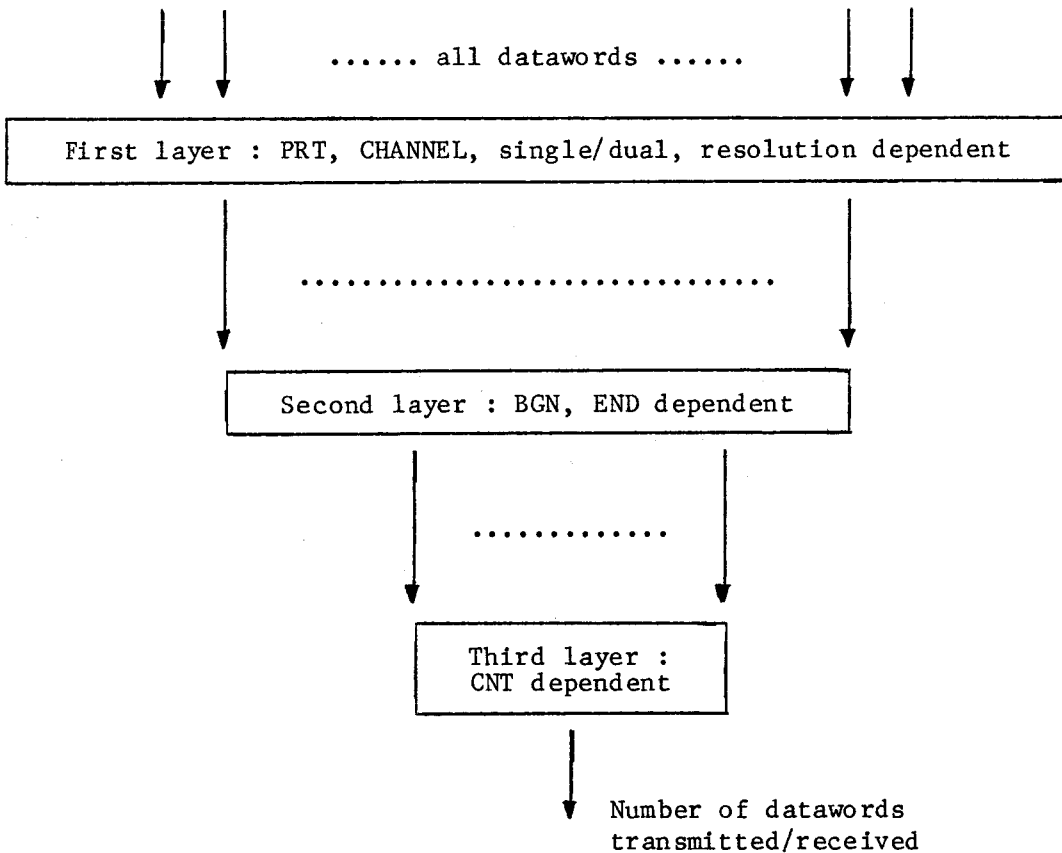

To illustrate how the first layer operates, below a few examples are given of which datawords are transferred in various situations:

Single channel, high resolution (4096 samples)

PRT	ALL	REAL
CHANNEL		
A	0,1,2,3,4,5,..	0,1,2,3,4,5,..
B	0,1,2,3,4,5,..	0,1,2,3,4,5,..
ALL	0,1,2,3,4,5,..	0,1,2,3,4,5,..

Single channel, low resolution (512 samples)

PRT	ALL	REAL
CHANNEL		
A	0,1,2,3,4,5,..	0,8,16,24,32,..
B	0,1,2,3,4,5,..	0,8,16,24,32,..
ALL	0,1,2,3,4,5,..	0,8,16,24,32,..

Dual channel, high resolution (4096 samples)

PRT	ALL	REAL
CHANNEL		
A	0,2,4,6,8,10,..	0,2,4,6,8,10,..
B	1,3,5,7,9,11,..	1,3,5,7,9,11,..
ALL	0,1,2,3,4,5,6,7,..	0,1,2,3,4,5,6,7,..

Dual channel, low resolution (512 samples)

PRT	ALL	REAL
CHANNEL		
A	0,2,4,6,8,10,..	0,8,16,24,32,..
B	1,3,5,7,9,11,..	1,9,17,25,33,..
ALL	0,1,2,3,4,5,6,7,..	0,1,8,9,16,17,..

NOTE :

If CHANNEL ALL on a dual channel register is selected, then always pairs of samples are transferred.

In the second layer the number of datawords is reduced, depending on the values of BGN and END, according to the following rules:

- The BGN and END values determine the maximum set of datawords that will be transferred, the BGN and END values themselves included.
- The BGN and END values are corrected if necessary. This can be seen when they are interrogated after a DAT ? or DAT ... command, which also gives the possibility to determine how many datawords were transferred.

Single channel

High resolution or PRT ALL selected	BGN is not adjusted
	END is not adjusted

Example:

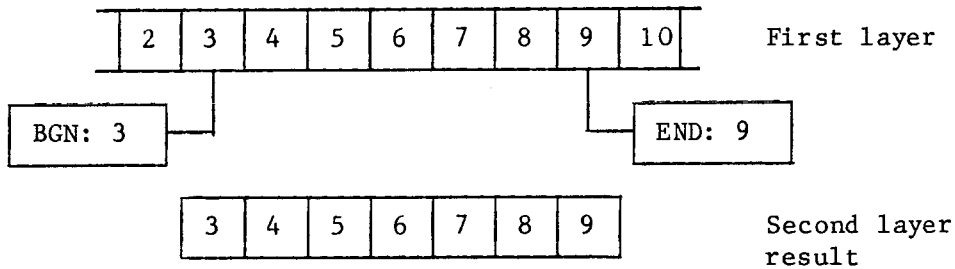

After the DAT command BGN=3 and END=9.

Single channel

Low resolution and PRT REAL selected	BGN is increased to first real sample
	END is decreased to last real sample

Example:

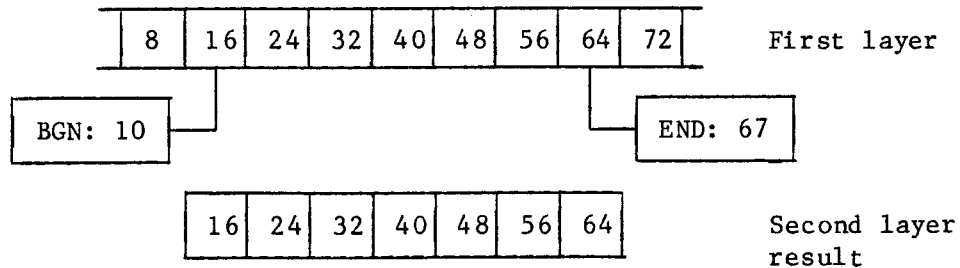

After the DAT command BGN=16 and END=64.

Dual channel

High resolution or PRT ALL selected	CHANNEL ALL	BGN is increased to first sample of A
		END is decreased to last sample of B
	CHANNEL A/B	BGN is increased to first sample of A/B
		END is decreased to last sample of A/B

Example:

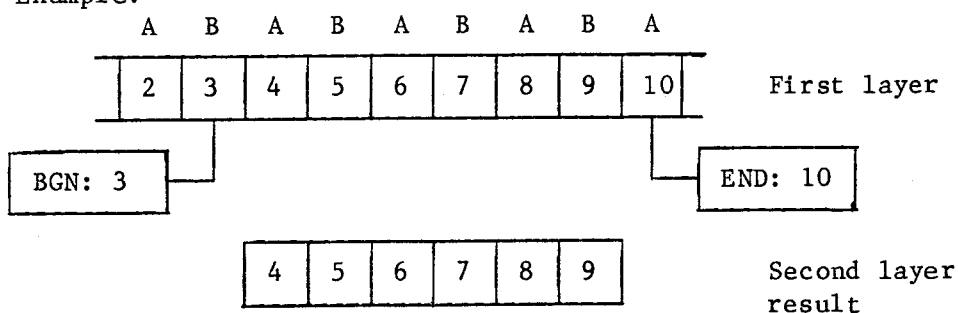

After the DAT command BGN=4 and END=9.

Dual channel

Low resolution and PRT REAL selected	CHANNEL ALL	BGN is increased to first real sample of A
		END is decreased to last real sample of B
	CHANNEL A/B	BGN is increased to first real sample of A/B
		END is decreased to last real sample of A/B

Example:

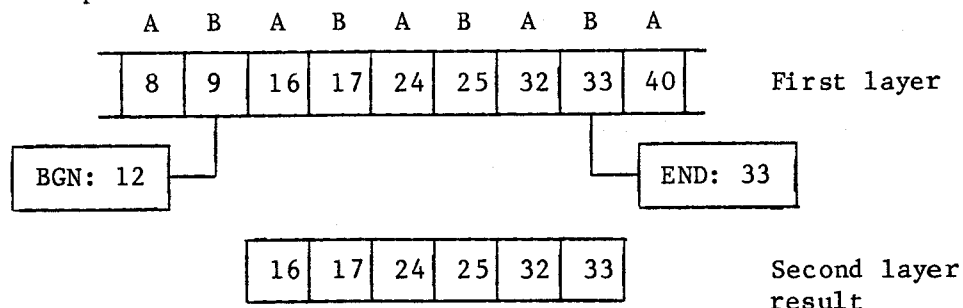

After the DAT command BGN=16 and END=33.

In the third layer the number of datawords is reduced, depending on the value of CNT.

The operation of CNT can be described in a pseudo high level programming language as follows:

```
FOR I=BGN(inclusive) TO END(inclusive) STEP CNT
  Select sample (I)
NEXT I
```

A few examples:

Single channel, high resolution and PRT ALL selected:

0	1	2	3	4	5	6	7	8	9	10
---	---	---	---	---	---	---	---	---	---	----

Second layer

CNT=2

0	2	4	6	8	10	12	14	16	18	20
---	---	---	---	---	----	----	----	----	----	----

Third layer

CNT=6

0	6	12	18	24	30	36	42	48	54	60
---	---	----	----	----	----	----	----	----	----	----

Third layer

Dual channel, low resolution and PRT REAL selected:

0	1	8	9	16	17	24	25	32	33	40
---	---	---	---	----	----	----	----	----	----	----

Second layer

CNT=2

0	1	16	17	32	33	48	49	64	65	80
---	---	----	----	----	----	----	----	----	----	----

Third layer

CNT=3

0	6	24	25	48	49	72	73	96	97	120
---	---	----	----	----	----	----	----	----	----	-----

Third layer

NOTES :

- If an error occurs, due to incorrect programming, a service request with error code 97 will be given. In this case the BGN and END values are not modified by the oscilloscope, as described in the second layer section.
- If during a data transfer to the oscilloscope less points are sent as expected, based on the principle described above, then the oscilloscope answers with a service request with error code 97. The sent points are placed at the start of the register. The missing addresses are filled with zeroes.

- If during a data transfer to the oscilloscope more points are sent as expected, based on the principle described above, then the oscilloscope answers with a service request with error code 97. From the points only the specified number is placed in the register, thereby using the last sent points.
- If during a data transfer from the oscilloscope to the controller the data output is stopped too early by the controller and the controller sets the oscilloscope to UNTALK, then the oscilloscope will generate a service request with error code 100, to indicate that there is more data ready to be sent.

7.3.6 Main function SPECIAL

SPL INTERFACE, SPL TEXT, SPL CURSOR, SPL MATHEMATICS, SPL SETMEM and SPL SERVICE are the special main functions of the oscilloscope. They are only selectable under the superfunction FRO \emptyset , except SPL INTERFACE, which can be selected under any superfunction.

The next table gives a clear overview of the available low functions per main function.

A request for the special settings within a main function can be done by programming SPL ? .

The answer is dependent on the previously selected main function.

The answers of SPL INTERFACE are only given if the previously selected main function was SPL INTERFACE.

7.3.6.1 TABLE VIII Low functions valid for main function SPL INTERFACE

SPL INTERFACE selects the special interface functions.

Low functions valid for main function SPL INTERFACE

PM33xx	Header:	Body:	Function or response:
20A 40	INTF	IEEE488. \emptyset	Selects the IEEE interface. Before programming this function SPL INTERFACE has always to be programmed first!
20A 40	INTF	?	INTF IEEE488. \emptyset usp ADDRESS XX usp TL_MODE .. usp USP .. usp BSP .. usp SPR .. usp WTD XXXXX
20A 40	INTF	RS232_IN. \emptyset	Selects the RS232 interface for data input. Before programming this function always SPL INTERFACE has to be programmed first!
20A 40	INTF	?	INTF RS232_IN. \emptyset usp DATA X usp PARITY .. usp BAUDRATE XXXXX usp USP .. usp BSP .. usp SPR ..
20A 40	INTF	RS232_OUT. \emptyset	Selects the RS232 interface for data output. Before programming this function always SPL INTERFACE has to be programmed first!
20A 40	INTF	?	INTF RS232_OUT. \emptyset usp DATA X usp STOP X usp PARITY .. usp BAUDRATE XXXXX usp USP .. usp BSP .. usp SPR ..
20A 40	ADDRESS	XX	Selection of the IEEE device address of the oscilloscope. XX is a number between 1 and 30. This can only be programmed after the INTF IEEE488. \emptyset command has been given.
20A 40	ADDRESS	?	ADDRESS XX This can only be programmed after the INTF IEEE488. \emptyset command has been given.
20A 40	TL_MODE	TO	Sets the oscilloscope in the TALK ONLY state This can only be programmed after the INTF IEEE488. \emptyset command has been given.

Low functions valid for main function SPL INTERFACE

PM33xx	Header:	Body:	Function or response:
20A 40	TL_MODE	LO	<p>Sets the oscilloscope in the LISTEN ONLY state.</p> <p>This can only be programmed after the INTF IEEE488.0 command has been given.</p>
20A 40	TL_MODE	TL	<p>Sets the oscilloscope in the talk/listen (addressed) mode.</p> <p>This can only be programmed after the INTF IEEE488.0 command has been given.</p>
20A 40	TL_MODE	?	<p>TL_MODE TO, TL_MODE LO or TL_MODE TL</p> <p>Note that this request function is only possible if communication is possible.</p> <p>This can only be programmed after the INTF IEEE488.0 command has been given.</p>
20A 40	STOP	X	<p>Selection of the number of stop bits in the data frame. X can be 1 or 2.</p> <p>This can only be programmed after the INTF RS232_....0 command has been given.</p>
20A 40	STOP	?	<p>STOP 1 or STOP 2</p> <p>This can only be programmed after the INTF RS232_....0 command has been given.</p>
20A 40	DATA	X	<p>Selection of the number of data bits in the data frame. X can be 7 or 8.</p> <p>This can only be programmed after the INTF RS232_....0 command has been given.</p>
20A 40	DATA	?	<p>DATA 7 or DATA 8</p> <p>This can only be programmed after the INTF RS232_....0 command has been given.</p>
20A 40	PARITY	ODD	<p>Selection of odd parity (odd number of "ones" in the data part of the frame).</p> <p>This can only be programmed after the INTF RS232_....0 command has been given.</p>
20A 40	PARITY	EVN	<p>Selection of even parity (even number of "ones" in the data part of the frame).</p> <p>This can only be programmed after the INTF RS232_....0 command has been given.</p>
20A 40	PARITY	NO	<p>Selection of <u>no</u> parity.</p> <p>This can only be programmed after the INTF RS232_....0 command has been given.</p>
20A 40	PARITY	?	<p>PARITY ODD, PARITY EVN or PARITY NO</p> <p>This can only be programmed after the INTF RS232_....0 command has been given.</p>

Low functions valid for main function SPL INTERFACE

PM33xx	Header:	Body:	Function or response:
20A 40	BAUDRATE	XXXXX	Selection of the baudrate of the serial interface. XXXXX can be 75, 110, 150, 300, 600, 1200, 2400, 4800, 9600, or 19200 baud. This can only be programmed after the INTF RS232_....Ø command has been given.
20A 40	BAUDRATE	?	BAUDRATE XXXXX This can only be programmed after the INTF RS232_....Ø command has been given.
20A 40	DESTINATION	IEEE488.Ø	Selection of the IEEE interface as destination for data output. NOTE: The use of another destination as the controlling device, is only possible in REMOTE mode.
20A 40	DESTINATION	RS232_OUT.Ø	Selection of the RS232 interface as destination for data output. NOTE: The use of another destination as the controlling device, is only possible in REMOTE mode.
20A 40	DESTINATION	?	DESTINATION IEEE488.Ø or DESTINATION RS232_OUT.Ø
20A 40	SOURCE	IEEE488.Ø	Selection of the IEEE interface as source for data input.
20A 40	SOURCE	RS232_OUT.Ø	Selection of the RS232 interface as source for data input.
20A 40	SOURCE	?	SOURCE IEEE488.Ø or SOURCE RS232_IN.Ø

NOTE: - After changing an interface setting a short waittime is required to allow the interface to reinitialize, otherwise a system hang-up is possible.

7.3.6.2 TABLE IX: Low functions valid for main function SPL TEXT

This main function can be selected after the selection of a usertext area by programming:

SPL SERVICE usp TEXT_MODE where usp is the unit separator.

After programming SPL TEXT the following usertext functions are available.

Low functions valid for main function SPL TEXT

PM33xx	Header:	Body:	Function or response:
20A 40	PAGE	Ø	Enabling the text area, which was selected by SPL SERVICE usp TEXT_MODE PAGE (or TOP or MID or BOTTOM), for display.
20A 40	PAGE	1	Enabling the text area, which was selected by SPL SERVICE usp TEXT_MODE SOFTKEY, for display.
20A 40	PAGE	?	PAGE Ø or PAGE 1
20A 40	LINE	XX	Selection of one of the eight available vertical textlines Ø ... 7 for TEXT_MODE PAGE, TOP, MID or BOTTOM and one of the eleven vertical textlines Ø ... 10 for TEXT_MODE SOFTKEY.
20A 40	LINE	?	LINE XX
20A 40	COLUMN	XX	Selection of one of the fifty available horizontal columns Ø ... 49 for TEXT_MODE PAGE, TOP, MID or BOTTOM and one of the ten available horizontal columns Ø ... 9 for TEXT_MODE SOFTKEY.
20A 40	COLUMN	?	COLUMN XX
20A 40	TEXT	C...C	C...C is a string of ASCII characters, which form together the usertext to be displayed on the screen in the selected text area.
20A 40	CHAR	XX	XX is one of the following numbers, which are active within the last selected PAGE. 6 Select low text intensity 7 Select high text intensity 8 Shift cursor one position to the left, with wrap around until the top of the page 9 Shift cursor one position to the left, with wrap around until the bottom of the page 10 Shift cursor one line down, until the bottom of the page 11 Shift cursor one line up, until the top of the page 12 Select page clear 13 Select line clear

Low functions valid for main function SPL TEXT

PM33xx	Header:	Body:	Function or response:
20A 40	CHAR	?	CHAR XX
			XX = 6, 7, 8, 9, 10, 11,12 or 13

7.3.6.3 TABLE X: Low functions valid for main function SPL SERVICE

SPL SERVICE selects the service functions.

Low functions valid for main function SPL SERVICE

PM33xx	Header:	Body:	Function or response:
20A 40	SERVICE	ON	Select the SERVICE MENU
20A 40	SERVICE	2	Select OUTPUT PORT test
20A 40	SERVICE	3	Select A&B OFFSET
20A --	SERVICE	4	Select A&B VARIABLE
20A --	SERVICE	5	Select A&B SHIFT
-- 40	SERVICE	5	Select TRIGGER DELAY
20A 40	SERVICE	6	Select TRIGGER LEVEL
20A --	SERVICE	7	Select EVT LEVEL
-- 40	SERVICE	7	Select HOLD OFF
-- 40	SERVICE	8	Select FAST RAMP
-- 40	SERVICE	9	Select ADJ TIME BASE
20A --	SERVICE	10	Select CHECK & ADJ VERTICAL X
20A --	SERVICE	11	Select CHECK & ADJ TRIGGER X
20A 40	SERVICE	12	Select CHECK & ADJ DISPLAY X
20A 40	SERVICE	13	Select DPU test
20A 40	SERVICE	14	Select SYSTEM test
20A 40	SERVICE	15	Select RAM test
20A --	SERVICE	17	Select DELTA-T test
20A 40	SERVICE	OFF	Switching off of the selected function
20A 40	SERVICE	UP	Performance of the NEXT function
20A 40	SERVICE	DOWN	Performance of the PREVIOUS function
20A 40	SERVICE	NORMAL	This command ends the automatic increase of decrease of the body number of the service menu.
20A 40	SERVICE	FAULT	Select the SERVICE FAULT FIND MENU
20A 40	SERVICE	CHECK	Select the SERVICE CHECK & ADJ MENU
20A 40	SERVICE	?	SERVICE ON or SERVICE 2 ... 17 or SERVICE OFF
20A 40	DATE	yy-mm-dd	Setting of a new date. yy = year mm = month dd = day
20A 40	DATE	?	DATE yy-mm-dd
20A 40	TIME	hh:mm:ss	Setting of a new time. hh = hours mm = minutes ss = seconds
20A 40	TIME	?	TIME hh:mm:ss

Low functions valid for main function SPL SERVICE

PM33xx	Header:	Body:	Function or response:
20A 40	TEXT_MODE	PAGE	Selection of the top text area, the reduced text area and the bottom text area for user text display. The eight available text lines are equally divided over the screen.
20A 40	TEXT_MODE	TOP	Selection of the top text area for user text display.
20A 40	TEXT_MODE	MID	Selection of the reduced text area for user text display.
20A 40	TEXT_MODE	BOTTOM	Selection of the bottom text area for user text display.
20A 40	TEXT_MODE	SOFTKEY	Selection of the softkey text area for user text display.
20A 40	TEXT_MODE	OSC	Switches all the user text areas back to the oscilloscope again.
20A 40	TEXT_MODE	?	Answer is TEXT_MODE USER or TEXT_MODE OSC which indicates that text field is partly occupied by the user.

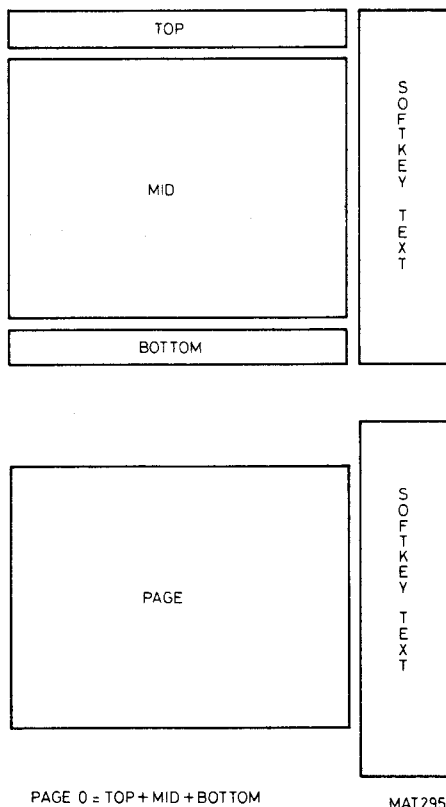

MAT2956

Figure 7.2 TEXT_MODE areas.

7.3.6.4 TABLE XI: Low functions valid for main function SPL CURSOR

SPL CURSOR selects the cursor functions.

Low functions valid for main function SPL CURSOR

PM33xx	Header:	Body:	Function or response:
20A 40	CUR	ON	Switches cursors on.
20A 40	CUR	OFF	Switches cursors off.
20A 40	CUR	TYPE_1	Select orthogonal cross type cursor.
20A 40	CUR	TYPE_2	Select rotated cross type cursor.
20A 40	CUR	TIME	Cursor positioning is done in horizontal direction.
20A 40	CUR	VOLT	Cursor positioning is done in vertical direction.
20A 40	CUR	PERIOD	This command positions the cursors in horizontal sense across one period of the signal.
20A 40	CUR	?	CUR OFF, CUR TIME or CUR VOLT
20A 40	FOR	FIRST_CURSOR	Select 1st cursor for further commands.
20A 40	FOR	SECOND_CURSOR	Select 2nd cursor for further commands
20A 40	FOR	REF_0	Select 0% reference for further commands.
20A 40	FOR	REF_100	Select 100% reference for further commands.
20A 40	FOR	?	FOR FIRST_CURSOR,REF_0 or FOR FIRST_CURSOR,REF_100 or FOR SECOND_CURSOR,REF_0 or FOR SECOND_CURSOR,REF_100
20A 40	DISP_REFS	ON	Switch reference level display of selected cursor on.
20A 40	DISP_REFS	OFF	Switch reference level display of selected cursor off.
20A 40	DISP_REFS	?	DISP_REFS ON or DISP_REFS OFF
20A 40	MOD	ABSOLUTE	Set selected cursor in absolute amplitude mode. Selects automatically amplitude mode.
20A 40	MOD	RELATIVE	Set selected cursor in relative amplitude mode. Selects automatically amplitude mode.
20A 40	MOD	?	MOD ABSOLUTE or MOD RELATIVE
20A 40	SEARCH	LEFT	Initiate searching from left side for the selected cursor. If searching from left was already initiated, then the occurrence counter is incremented.
20A 40	SEARCH	RIGHT	Initiate searching from right side for the selected cursor. If searching from right was already initiated, then the occurrence counter is incremented.

Low functions valid for main function SPL CURSOR

PM33xx	Header:	Body:	Function or response:
20A 40	SEARCH	X	Set the last selected search direction occurrence counter to the value X in the range 1 to 9.
20A 40	SEARCH	?	SEARCH LEFT,X or SEARCH RIGHT,X X is the occurrence counter value.
20A 40	REFERENCE	MIN_PEAK	Set selected reference level of selected cursor at minimum signal peak.
20A 40	REFERENCE	MAX_PEAK	Set selected reference level of selected cursor at maximum signal peak.
20A 40	REFERENCE	GROUND	Set selected reference level of selected cursor at ground level.
20A 40	REFERENCE	ABSOLUTE	Set selected reference level of selected cursor at an absolute level.
20A 40	REFERENCE	XXXX	Set selected reference level of selected cursor at the specified absolute level. The range lies between 0 (bottom screen) and 4095 (top screen). Selects automatically absolute mode.
20A 40	REFERENCE	PROB_LOW	Set selected reference level of selected cursor at most probable low level of the signal.
20A 40	REFERENCE	PROB_HIGH	Set selected reference level of selected cursor at most probable high level of the signal.
20A 40	REFERENCE	?	REFERENCE MIN_PEAK,SXXXXXXXXXESYY or REFERENCE MAX_PEAK,SXXXXXXXXXESYY or REFERENCE GROUND or REFERENCE PROB_LOW or REFERENCE PROB_HIGH or REFERENCE XXXX
20A 40	FIRST	XXXX	Command for positioning of first cursor. XXXX determines the position and is a value in the range 0 to 4095.
20A 40	FIRST	?	FIRST XXXX,SXXXXXXXXXESYY,SXXXXXXXXXESYY XXXX represents the horizontal position of the first cursor. SXXXXXXXXXESYY is a floating point value. The first one is the amplitude position of the first cursor, including offset. The second one is the time position of the first cursor, including trigger delay. These values are only updated if the cursors are on.

Low functions valid for main function SPL CURSOR

PM33xx	Header:	Body:	Function or response:
20A 40	RFIRST	XXXX	Command for repositioning of first cursor compared with its original position. XXXX determines the cursor displacement and is a value in the range 0 to 4095.
20A 40	RFIRST	?	Answer is always RFIRST 0
20A 40	FIRST_CURSOR	R0	First cursor is assigned to register R0.
20A 40	FIRST_CURSOR	R1	First cursor is assigned to register R1.
20A 40	FIRST_CURSOR	R2	First cursor is assigned to register R2.
20A 40	FIRST_CURSOR	R3	First cursor is assigned to register R3.
20A 40	FIRST_CURSOR	A	First cursor is assigned to channel A in the selected register. Command is only necessary if two channels are stored in this register.
20A 40	FIRST_CURSOR	B	First cursor is assigned to channel B in the selected register. Command is only valid if two channels are stored in this register.
20A 40	FIRST_CURSOR	?	FIRST_CURSOR RX,Y X indicates the register number (0, 1, 2 or 3) and Y the selected channel (A or B).
20A 40	SECOND	XXXX	Command for positioning of second cursor. XXXX determines the position and is a value in the range 0 to 4095.
20A 40	SECOND	?	SECOND XXXX,SXXXXXXXXXESYY,SXXXXXXXXXESYY XXXX represents the horizontal position of the second cursor. SXXXXXXXXXESYY is a floating point value. The first one is the amplitude position of the second cursor, including offset. The second one is the time position of the second cursor, including trigger delay. These values are only updated if the cursors are on.
20A 40	RSECOND	XXXX	Command for repositioning of second cursor compared with its original position. XXXX determines the displacement and is a value in the range 0 to 4095.
20A 40	RSECOND	?	Answer is always RSECOND 0
20A 40	SECOND_CURSOR	R0	Second cursor is assigned to register R0.
20A 40	SECOND_CURSOR	R1	Second cursor is assigned to register R1.
20A 40	SECOND_CURSOR	R2	Second cursor is assigned to register R2.
20A 40	SECOND_CURSOR	R3	Second cursor is assigned to register R3.

Low functions valid for main function SPL CURSOR

PM33xx	Header:	Body:	Function or response:
20A 40	SECOND_CURSOR	A	Second cursor is assigned to channel A in the selected register. Command is only necessary if two channels are stored in this register.
20A 40	SECOND_CURSOR	B	Second cursor is assigned to channel B in the selected register. Command is only necessary if two channels are stored in this register.
20A 40	SECOND_CURSOR	?	SECOND_CURSOR RX,Y X indicates the register number (0, 1, 2 or 3) and Y the selected channel (A or B).
20A 40	CAL	ON	This command initiates the calibration of the analog front end of the oscilloscope.
20A 40	CAL	?	CALIBRATE ON or CALIBRATE INACTIVE
20A --	ACQUISITION	RESTART	This command starts the restart function. This command is only possible if both cursors are assigned to register R0.
20A --	ACQUISITION	REVERSE	This command resets an already initiated restart function by restoring the situation from before the restart. This function is only possible as long as the situation from before the first restart has not been reached.
20A --	ACQUISITION	?	ACQUISITION RESTART or ACQUISITION REVERSE
20A 40	RMS	ON	Command switches rms function on. Is only possible if both cursors are assigned to same register and channel.
20A 40	RMS	OFF	Command switches the function off.
20A 40	RMS	?	RMS OFF or RMS SXXXXXXXXXESYY
20A 40	MEAN	ON	Command switches mean function on. Is only possible if both cursors are assigned to same register and channel.
20A 40	MEAN	OFF	Command switches mean function off.
20A 40	MEAN	?	MEAN OFF or MEAN SXXXXXXXXXESYY
20A 40	PEAK	ON	Command switches the peak function on. Is only possible if both cursors are assigned to same register and channel.
20A 40	PEAK	OFF	Command switches peak function off.
20A 40	PEAK	?	PEAK OFF or PEAK SXXXXXXXXXESYY

Low functions valid for main function SPL CURSOR

PM33xx	Header:	Body:	Function or response:
20A 40	V_MARK	ON	Command switches the amplitude markers on, provided that the function peak, overshoot or preshoot is active.
20A 40	V_MARK	OFF	Command switches the amplitude markers off.
20A 40	V_MARK	?	V_MARK OFF or V_MARK SXXXXXXXXXESYY usp SXXXXXXXXXESYY Only if peak, overshoot or preshoot is on.
20A 40	RISE	ON	Command switches the rise time function on provided that the cursors are assigned to the same register and channel.
20A 40	RISE	OFF	Command switches the rise time function off.
20A 40	RISE	TTL	This command adjusts the limits for rise time calculations to 10 and 90 % such as required for TTL logic.
20A 40	RISE	ECL	This command adjusts the limits for rise time calculations to 20 and 80 % such as required for ECL logic.
20A 40	RISE	VAR	This command enables to set the limits to an adjustable value.
20A 40	RISE	?	If this function is not active the answer is TTL, ECL or in VAR mode a multiple body of two integers that indicate the adjusted begin limit and end limit. If the rise mode is active, the answer is the rise time SXXXXXXXXXESYY.
20A 40	BGN	XXX	This command enables adjustment of the begin limit if RISE VAR is active. The number XXX is a value in the range 0 to 100 indicating the percentage of the signal amplitude.
20A 40	END	XXX	This command enables adjustment of the end limit if RISE VAR is active. The number XXX is a value in the range 0 to 100 indicating the percentage of the signal amplitude.
20A 40	FREQ	ON	Switches frequency measuring mode on. Is only possible if cursors are assigned to same register and channel.
20A 40	FREQ	OFF	Switches frequency measuring mode off.
20A 40	FREQ	?	FREQ OFF or FREQ SXXXXXXXXXESYY
20A 40	OVERSHOOT	ON	Switches the overshoot measuring mode on. Is only possible if cursors are assigned to same register and channel.
20A 40	OVERSHOOT	OFF	Switches the overshoot measuring mode off.
20A 40	OVERSHOOT	?	OVERSHOOT OFF or OVERSHOOT SXXXXXXXXXESYY

Low functions valid for main function SPL CURSOR

PM33xx	Header:	Body:	Function or response:
20A 40	PRE_SHOOT	ON	Switches the preshoot measuring mode on. Is only possible if cursors are assigned to same register and channel.
20A 40	PRE_SHOOT	OFF	Switches the preshoot measuring mode off.
20A 40	PRE_SHOOT	?	PRESHOOT OFF or PRESHOOT SXXXXXXXXXXESYY
20A 40	PULSE_WIDTH	ON	Switches the pulse width measuring mode on. Is only possible if cursors are assigned to same register and channel.
20A 40	PULSE_WIDTH	OFF	Switches the pulse width measuring mode off.
20A 40	PULSE_WIDTH	?	PULSE_WIDTH OFF or PULSE_WIDTH SXXXXXXXXXXESYY
20A 40	DUTY_CYCLE	ON	Switches the duty cycle measuring mode on. Is only possible if cursors are assigned to same register and channel.
20A 40	DUTY_CYCLE	OFF	Switches the duty cycle measuring mode off.
20A 40	DUTY_CYCLE	?	DUTY_CYCLE OFF or DUTY_CYCLE SXXXXXXXXXXESYY
20A 40	T_MARK	ON	This command switches the time markers on provided that the time measurement mode is active.
20A 40	T_MARK	OFF	This command switches the time markers off.
20A 40	T_MARK	?	T_MARK OFF or T_MARK SXXXXXXXXXXESYY usp SXXXXXXXXXXESYY being respectively the time between the first marker and beginning of display and the second marker and beginning of display.
20A 40	DTIME	ON	This command switches the delta time function on and the time between both cursors can be read.
20A 40	DTIME	OFF	This command switches the delta time function off. At the same time function INV_DTIME switches on.
20A 40	DTIME	?	DTIME OFF or DTIME SXXXXXXXXXXESYY being the time between both cursors.
20A 40	INV_DTIME	ON	This command switches the inverted delta time function on and 1/(time between both cursors) can be read.
20A 40	INV_DTIME	OFF	This command switches the inverted delta time function off. At the same time function DTIME switches on.
20A 40	INV_DTIME	?	INV_DTIME OFF or INV_DTIME SXXXXXXXXXXESYY being the value 1/(time between both cursors) in Hz.

Low functions valid for main function SPL CURSOR

PM33xx	Header:	Body:	Function or response:
20A 40	DVOLT	?	DVOLT OFF or DVOLT SXXXXXXXXXESYY being the voltage difference between both cursors.
20A 40	PHASE	R0	Selects R0 as the register in which the phase measurement is performed.
20A 40	PHASE	R1	Selects R1 as the register in which the phase measurement is performed.
20A 40	PHASE	R2	Selects R2 as the register in which the phase measurement is performed.
20A 40	PHASE	R3	Selects R3 as the register in which the phase measurement is performed.
20A 40	PHASE	A	Selects within the choosen register A as the phase determining channel.
20A 40	PHASE	B	Selects within the choosen register B as the phase determining channel.
20A 40	PHASE	ON	This command starts the phase measurement.
20A 40	PHASE	OFF	This command stops the phase measurement.
20A 40	PHASE	?	PHASE OFF or PHASE SXXXXXXXXXESYY
20A 40	OFS	YES	This command determines that the adjusted channel offset is included in the calculations.
20A 40	OFS	NO	This command determines that the adjusted channel offset is not included in the calculations.
20A 40	OFS	?	OFS YES or OFS NO

7.3.6.5 TABLE XII: Low functions valid for main function SPL MATHEMATICS

SPL MATHEMATICS selects the mathematical functions.

Low functions valid for main function SPL MATHEMATICS

PM33xx	Header:	Body:	Function or response:
20A 40	ADD	ON	Activates the added function.
20A 40	ADD	OFF	Switches the added function off.
20A 40	ADD	?	ADD ON or ADD OFF
20A 40	SUB	ON	Activates the subtract function.
20A 40	SUB	OFF	Switches the subtract function off.
20A 40	SUB	?	SUB ON or SUB OFF
20A 40	MUL	ON	Activates the multiply function.
20A 40	MUL	OFF	Switches the multiply function off.
20A 40	MUL	?	MUL ON or MUL OFF
20A 40	DIV	ON	Activates the divide function.
20A 40	DIV	OFF	Switches the divide function off.
20A 40	DIV	?	DIV ON or DIV OFF
20A 40	INT	ON	Activates the integrate function.
20A 40	INT	OFF	Switches the integrate function off.
20A 40	INT	?	INT ON or INT OFF
20A 40	DIF	ON	Activates the differentiate function.
20A 40	DIF	OFF	Switches the differentiate function off.
20A 40	DIF	?	DIF ON or DIF OFF
20A 40	DLY	ON	Activates the delay function.
20A 40	DLY	OFF	Switches the delay function off.
20A 40	DLY	?	DLY ON or DLY OFF
20A 40	FFT	ON	Activates the fast fourier transformation (FFT is an optional function).
20A 40	FFT	OFF	Switches the fast fourier transformation off.
20A 40	FFT	?	FFT ON or FFT OFF
20A 40	HIS	ON	Activates the histogram function.
20A 40	HIS	OFF	Switches the histogram function off.
20A 40	HIS	?	HIS ON or HIS OFF
20A 40	FIL	ON	Activates the filter function.
20A 40	FIL	OFF	Switches the filter function off.

Low functions valid for main function SPL MATHEMATICS

PM33xx	Header:	Body:	Function or response:
20A 40	FIL	?	FIL ON or FIL OFF
20A 40	FIRST_SOURCE	R0	Selects R0 as the register from which the first source signal is taken.
20A 40	FIRST_SOURCE	R1	Selects R1 as the register from which the first source signal is taken.
20A 40	FIRST_SOURCE	R2	Selects R2 as the register from which the first source signal is taken.
20A 40	FIRST_SOURCE	R3	Selects R3 as the register from which the first source signal is taken.
20A 40	FIRST_SOURCE	A	Selects within chosen register A as the channel on which the mathematical function is carried out. Not applicable for the DLY-function.
20A 40	FIRST_SOURCE	B	Selects within chosen register B as the channel on which the mathematical function is carried out. Not applicable for the DLY-function.
20A 40	FIRST_SOURCE	?	FIRST_SOURCE RX,Y X indicates the register number (0, 1, 2 or 3) and Y the selected channel (A or B).
20A 40	SECOND_SOURCE	R0	Selects R0 as the register from which the second source signal is taken.
20A 40	SECOND_SOURCE	R1	Selects R1 as the register from which the second source signal is taken.
20A 40	SECOND_SOURCE	R2	Selects R2 as the register from which the second source signal is taken.
20A 40	SECOND_SOURCE	R3	Selects R3 as the register from which the second source signal is taken.
20A 40	SECOND_SOURCE	A	Selects within chosen register A as the channel on which the mathematical function is carried out. Not applicable for the DLY-function.
20A 40	SECOND_SOURCE	B	Selects within chosen register B as the channel on which the mathematical function is carried out. Not applicable for the DLY-function.
20A 40	SECOND_SOURCE	?	SECOND_SOURCE RX,Y X indicates the register number (0, 1, 2 or 3) and Y the selected channel (A or B).
20A 40	RESULT	R0	Selects R0 as the register in which the calculation result is stored.
20A 40	RESULT	R1	Selects R1 as the register in which the calculation result is stored.

Low functions valid for main function SPL MATHEMATICS

PM33xx	Header:	Body:	Function or response:
20A 40	RESULT	R2	Selects R2 as the register in which the calculation result is stored.
20A 40	RESULT	R3	Selects R3 as the register in which the calculation result is stored.
20A 40	RESULT	?	RESULT R0, RESULT R1, RESULT R2 or RESULT R3
20A 40	SCALE	ZERO	This command resets the scale factor to 1.
20A 40	SCALE	XXXXX	The scale factor is set to XXXXX, which is a value in the range 1 to 32767.
20A 40	SCALE	?	SCALE XXXXX
20A 40	DELAY	ZERO	This command resets the delay to 0.
20A 40	DELAY	A	Selects A as the channel to be delayed compared with the other.
20A 40	DELAY	B	Selects B as the channel to be delayed compared with the other.
20A 40	DELAY	SXXXX	The delay is set to SXXXX, which is a value in the range -1024 to 1023.
20A 40	DELAY	?	DELAY SXXXX
20A 40	UPDOWN	XXX	The number XXX can be 1, 10 or 100 and determines the speed of the UP and DOWN function between normal ... fast.
20A 40	UPDOWN	?	UPDOWN 1, UPDOWN 10 or UPDOWN 100
20A 40	LIMIT	CURSOR	This command switches the cursor limit function on.
20A 40	LIMIT	NO	This command switches the cursor limit function off.
20A 40	LIMIT	?	LIMIT CURSOR or LIMIT NO
20A 40	OFS	YES	This command determines that the adjusted channel offset is included in the calculations.
20A 40	OFS	NO	This command determines that the adjusted channel offset is not included in the calculations.
20A 40	OFS	?	OFS YES or OFS NO
20A 40	WINDOW	HANNING	Activates the HANNING window that is used for the FFT process.
20A 40	WINDOW	HAMMING	Activates the HAMMING window that is used for the FFT process.

Low functions valid for main function SPL MATHEMATICS

PM33xx	Header:	Body:	Function or response:
20A 40	WINDOW	NO	No filter is active for the FFT process.
20A 40	WINDOW	?	WINDOW HANNING, WINDOW HAMMING or WINDOW NO
20A 40	FIL_ORDER	XXX	The filter order is set to XXX. XXX can have the values 3, 5, 9, 17, 33, 65 or 129.
20A 40	FIL_ORDER	?	FIL_ORDER XXX
20A 40	DIF_DISTANCE	XX	The differential distance is set to XX. XX can have the values 1, 2, 4, 8, 16, 32 or 64.
-- 40	DIF_DISTANCE	?	DIF_DISTANCE XX

7.3.6.6 TABLE XIII: Low functions valid for main function SPL SETMEM

SPL SETMEM selects the setting memory functions.

Low functions valid for main function SPL SETMEM

PM33xx	Header:	Body:	Function or response:
20A 40	SETTING	XX.XX	A front number between 01.00 and 99.99 can be selected for use by the user. This front is then automatically recalled.
20A 40	SETTING	?	SETTING XX.XX or SETTING NO
20A 40	SETTING	RECALL	The front number which is displayed in the softkey text area is made actual.
20A 40	SETTING	NEXT	The displayed front number is increased (stepping up) until the highest possible front number in the sequence is reached. The repeat factor is about 300 ms. NOTE: The SETTING NEXT function remains in the active state until a SETTING NORMAL is sent. One single step can be programmed by: SETTING NEXT usp SETTING NORMAL usp is the unit separator.
20A 40	SETTING	PREVIOUS	The displayed front number is decreased (stepping down) until the lowest possible front number in the sequence is reached. The repeat factor is about 300 ms. NOTE: The SETTING PREVIOUS function remains in the active state until a SETTING NORMAL is sent. One single step can be programmed by: SETTING PREVIOUS usp SETTING NORMAL usp is the unit separator.
20A 40	SETTING	NORMAL	Ends the automatic increase or decrease of the front number caused by a previous send SETTING UP or SETTING DOWN command.
20A 40	SETTING	INSERT	The actual front panel setting will be inserted after the front number which is displayed in the softkey text area.
20A 40	SETTING	DELETE	The selected front panel setting is removed from the sequence and all higher front numbers will be decreased by one.
20A 40	SETTING	SAVE	Save the actual front panel setting under the number which is visible in the softkey text area.
20A 40	SETTING	EOS	All fronts in the sequence after the selected front are deleted.
20A 40	FRONT	XX.XX	A front number between 01.00 and 99.99 can be selected for programming.

Low functions valid for main function SPL SETMEM

PM33xx	Header:	Body:	Function or response:
20A 40	FRONT	?	FRONT XX.XX or FRONT NO
20A 40	FRONT	UP	<p>The displayed (main) front number is increased (stepping up) until the highest possible (main)front number in the sequence is reached.</p> <p>The repeat factor is about 300 ms.</p> <p>NOTE: The FRONT UP function remains in the active state until a FRONT NORMAL is sent.</p> <p>One single step can be programmed by: FRONT UP usp FRONT NORMAL usp is the unit separator.</p>
20A 40	FRONT	DOWN	<p>The displayed (main) front number is decreased (stepping down) until the lowest possible (main)front number in the sequence is reached.</p> <p>The repeat factor is about 300 ms.</p> <p>NOTE: The FRONT DOWN function remains in the active state until a FRONT NORMAL is sent.</p> <p>One single step can be programmed by: FRONT DOWN usp FRONT NORMAL usp is the unit separator.</p>
20A 40	FRONT	NORMAL	Ends the automatic increase or decrease of the (main) front number caused by a FRONT UP or FRONT DOWN command.
20A 40	UPDOWN	MAIN	After this command the command FRONT UP or FRONT DOWN results in jumping from one main front to the other.
20A 40	UPDOWN	SEQUENCE	After this command the command FRONT UP or FRONT DOWN results in jumping from one front to the other within the selected main front.
20A 40	UPDOWN	?	UPDOWN MAIN or UPDOWN SEQUENCE

7.4 ERROR CODES

The oscilloscope displays warnings in the bottom text area on the screen, when the instrument is operated or programmed in a wrong way.

If an error is encountered in the statusword (equivalent decimal value 97) which is returned from the oscilloscope, it is possible to ask the oscilloscope for:

- the error number
- the error text

The following syntax is used:

MSC AUX usp ERROR ?	Request for the current error number and error text.
---------------------	--

The answer from the oscilloscope is:

ERROR XX usp <ERROR TEXT>

XX is the number of the current error and <ERROR TEXT> is the text belonging to this specific error.

Example:

Error number	Error text
--------------	------------

82	<pre> * * * * * AUTO SET BUSY * </pre>
----	--

See also the explanation of the device statusword in section 4.8.

8. PROGRAMMING EXAMPLES

8.1 INTRODUCTION

This chapter gives a number of driver programs and programming examples for a number of different controllers.

Furthermore a number of more complex programming items are explained in more detail.

8.2 Driver programs

This section contains driver programs for the following controllers:

HP85

IBM

P2000C

The IEEE device address of the oscilloscope is assumed to be set to 8.

8.2.1 Driver program HP85 (IEEE)

```

10 ! DRIVER FOR SCOPES
20 LOCAL 7
30 CONTROL 7,16 ; 1,10
40 CLEAR
50 P=700
60 CLEAR
70 DISP "UNIVERSAL DRIVER FOR S
  CYPES"
80 DISP "-----"
90 DISP "YOU CAN TYPE IN THE CO
  MMANDS"
100 DISP "AFTER 'next command'"
110 DISP " "
120 DISP "TYPE RETURN TO PROCEED
  "
130 INPUT L$
140 BEEP
150 OUTPUT P USING "K" ; "SPL IN
  TERFACE"
160 OUTPUT P USING "K" ; "INTF I
  EEE488.0"
170 OUTPUT P USING "K" ; "SPR 10
  "
180 OUTPUT P USING "K" ; "USP 47
  "
190 CLEAR
200 DISP " "
210 DIM R$[1024]
220 DIM Q$[2048]
230 DIM A$[128]
240 Q$=" "
250 A$="SET AUT"
260 GOTO 350
270 S=0
280 S1=0
290 R$=" "
300 DISP
310 DISP "next command: ";

320 INPUT A$
330 IF A$="STOP" THEN GOTO 530
340 IF LEN(A$)=0 THEN CLEAR @ GO
  TO 300
350 OUTPUT P USING "K" ; A$
360 CLEAR
370 S1=SPOLL(P)
380 DISP "done: ";A$;"          st
  atus: ";S1
390 DISP "-----"
400 IF S1=98 THEN GOTO 560
410 IF S1=97 THEN GOTO 580
420 IF S1=100 THEN GOTO 440
430 GOTO 270
440 ENTER P ; R$
450 Q$=Q$&R$
460 DISP "LEN =";LEN(R$);" - ";LN
  UM(R$LEN(R$),LEN(R$))
470 IF LEN(R$)>222 THEN ENTER P
  ; R$ @ Q$=Q$&R$ @ GOTO 470
480 DISP "REPLY= ";Q$ @ Q$=" "
490 GOTO 270
500 DISP
510 DISP "NO REPLY"
520 GOTO 270
530 DISP "END"
540 END
550 BEEP 50,100
560 DISP "INTERFACE ERROR"
570 GOTO 270
580 DISP "PROGRAMMING ERROR"
590 GOTO 270
600 CLEAR
610 DISP ""
620 DISP "END"
630 DISP "==="
640 BEEP
650 END

```

8.2.2 Driver program IBM (IEEE)

```

10 REM *****
20 '
30 '           UNIVERSAL DRIVER FOR 3100
40 '
50 '
60 '           REL DATE:86-10-02
70 '           SOFTWARE SUPPORT GROUP
80 REM *****
90 'Copyright 1986, N.V. Philips Gloeilampenfabrieken

```

```

DECLARATION PART (decl.bas)

```

```

570 '
580 CLS
590 ' START APPLICATION PROGRAM AFTER THIS LINE
600 '
610 AD=708 'scope adress=8
620 ADP=7 'adapter nr=7
630 SC=1 'adapter is sytem controller
640 CON=7:STATUS=30
650 MAX=255
660 TIME=5
670 CALL IOABORT(ADP)
680 CALL IORESET(ADP)
690 CALL IOINIT(AD,SC)
700 CALL IOCLEAR(AD)
710 CALL IOTIMEOUT(ADP,TIME)
720 CALL IOCONTRL(ADP,CON,STATUS)
730 PRINT "*****"
740 INPUT "COMMAND: ";WR$
750 IF LEFT$(WR$,2)="st" OR LEFT$(WR$,2)="ST" THEN 1010
760 LE=LEN(WR$)
770 CALL IOOUTPUTS(AD,WR$,LE)
780 GOSUB 910
790 GOSUB 930
800 IF STATUS<>100 THEN 730
810 PRINT "REPLY FROM SCOPE:"
820 PRINT "-----"
830 INFO$=SPACE$(MAX):RDNR=0
840 CALL IOENTERS(AD,INFO$,MAX,RDNR)
850 GOSUB 910
860 PRINT LEFT$(INFO$,RDNR);
870 IF RDNR>223 THEN GOTO 830
880 GOSUB 930
890 IF RDNR<255 THEN 730 ELSE 830
900 REM ***** SERIAL POLL *****
910 IF PCIB.ERR<>0 THEN PRINT PCIB.ERR$
920 RETURN
930 REM ***** SERIAL POLL *****
940 FOR Q=1 TO 100:NEXT Q
950 CALL IOSPOLL(AD,STATUS)
960 PRINT "SERIAL POLL: ",STATUS
970 IF STATUS = 97 THEN PRINT "PROGRAMMING ERROR"
980 IF STATUS =98 THEN PRINT "INTERNAL ERROR"
990 GOSUB 910
1000 RETURN
1010 CALL IOLOCAL(AD)
1020 CLS:END

```

8.2.3 Driver program IBM (Serial)

```

10 REM last rev. date:                870709
20 KEY OFF:CLS:CLOSE
30 VIEW PRINT
40 FALSE =0:TRUE= NOT FALSE
50 XOFF$=CHR$(19):XON$=CHR$(17)
60 LOCATE 1,1:PRINT "THE CURRENT INTERFACE SETTING IS 1200,N,8,1"
70 INPUT "DO YOU WANT TO CHANGE THIS (Y/N)";A$
80 IF LEFT$(A$,1)="Y" OR LEFT$(A$,1)="y" THEN GOTO 110
90 SPEED$="1200":DBIT$="8":STP$="1":PARIT$="N"
100 GOTO 150
110 LOCATE 4,1:LINE INPUT "SPEED(75...9600)      :?";SPEED$:IF SPEED$="" THEN SPE
ED$="1200"
120 LOCATE 5,1:LINE INPUT "DATA BITS(7,8)       :?";DBIT$:IF DBIT$="" THEN DBIT$
="8"
130 LOCATE 6,1:LINE INPUT "STOP BITS(1,2)       :?";STP$:IF STP$="" THEN STP$="1"
"
140 LOCATE 7,1:LINE INPUT "PARITY (No,Odd,Even) :?";PARI$:IF PARI$="" THEN PARIS
="N"
150 COMFIL$="COM1:"+SPEED$+", "+PARIT$+", "+DBIT$+", "+STP$+",RS,LF
160 OPEN COMFIL$ AS#1
170 CLS
180 FOR T=1 TO 80:PRINT"=";:NEXT T
190 PRINT"                I N T E R A C T I V E   P R O G R A M                type yo
ur command"
200 FOR T=1 TO 80:PRINT"=";:NEXT T
210 VIEW PRINT 5 TO 25
220 PAUSE=FALSE
230 LOCATE 25,1
240 B$="":N=0
250 A$=INKEY$:IF A$="" THEN 340
260 IF A$=CHR$(8) THEN GOTO 400
270 N=N+1
280 B$=B$+A$
290 LOCATE 25,N
300 PRINT A$;
310 IF ASC(A$)<>13 THEN GOTO 250
320 N=0
330 PRINT#1,B$:B$=""
340 IF EOF(1) THEN 250
350 IF LOC(1)>128 THEN PAUSE =TRUE:PRINT #1,XOFF$
360 A$=INPUT$(LOC(1),#1)
370 PRINT A$;:IF LOC(1)>0 THEN 350
380 IF PAUSE THEN PAUSE =FALSE:PRINT#1,XON$;
390 GOTO 250
400 IF B$="" THEN PRINT CHR$(7);:GOTO 250
410 B$=LEFT$(B$, (LEN(B$)-1))
420 IF N<=0 GOTO 250
430 LOCATE 25,N
440 PRINT " ";
450 LOCATE 25,N
460 N=N-1
470 GOTO 250

```

8.2.4 Driver program P2000C (IEEE)

```
10 PRINT CHR$(12)
20 PRINT "***** P2000_ SCOPE DRIVER *****"
30 PRINT:PRINT:PRINT
40 IEC INIT
50 REM ---- IEC-ADDRESS :
60 ADR=8
70 DIM R$(1512),B$(500)
80 DIM A$(128)
100 IEC PRINT #ADR,"USP /"
110 PRINT
120 PRINT "-----"
130 PRINT
140 S=0
150 S1=0
160 R$=" "
170 INPUT A$
180 IF A$="stop" THEN GOTO 310
190 IF A$="rest" THEN 260
200 IEC PRINT #ADR,A$
210 FOR I= 1 TO 200
220 NEXT I
230 IEC POLL #ADR,S1
240 PRINT "Serial poll=";S1
250 IF S1<>64 THEN GOTO 300
260 IEC INPUT #ADR,R$
270 PRINT "reply=";R$
280 GOTO 230
290 PRINT "no reply"
300 GOTO 110
310 PRINT "end"
320 END
330 IEC POLL #8,P
340 PRINT P
350 END
```

8.3 How to use the driver programs?

Just type in these programs in your controller and run them. The program asks you to enter commands as described in chapter 7.

Example: (IBM)

When the program is executed, the interface is cleared, set to a predefined status, and the oscilloscope performs an autoset.

The screen is cleared (line 580) and the controller asks you to enter a command.

COMMAND: ?

Then you can enter your command after the ? mark, and after typing return, the oscilloscope returns its statusword (SERIAL POLL:...) and/or the data you asked for.

```

*****
COMMAND: ? msc ?
SERIAL POLL: 100
REPLY FROM SCOPE:
-----
MSC R0,INV OFF,POS CAL,SET INACTIVE,PLT R0,SAV OFF,YVX OFF,YVT ON,DSP ON,SEL ALL
,XPOS 0,YPOS 0,XVAR 0,REDUCED OFF,FULL OFF,PENUP 0,MULSOURCE OFF,MULRESULT OFF,P
LOTTIME 20,SCREENPLOT ANALOG,RXPOS 0,RYPOS 0,RXVAR 0,MSC R1,INV
OFF,POS CAL,SET INACTIVE,PLT R0,SAV OFF,YVX OFF,YVT ON,DSP OFF,SEL ALL,XPOS 0,YP
OS 0,XVAR 0,REDUCED OFF,FULL OFF,PENUP 0,MULSOURCE OFF,MULRESULT OFF,PLOTTIME 20
,SCREENPLOT ANALOG,RXPOS 0,RYPOS 0,RXVAR 0,MSC R2,INV OFF,POS CA
L,SET INACTIVE,PLT R0,SAV OFF,YVX OFF,YVT ON,DSP OFF,SEL ALL,XPOS 0,YPOS 0,XVAR
0,REDUCED OFF,FULL OFF,PENUP 0,MULSOURCE OFF,MULRESULT OFF,PLOTTIME 20,SCREENPLO
T ANALOG,RXPOS 0,RYPOS 0,RXVAR 0,MSC R3,INV OFF,POS CAL,SET INAC
TIVE,PLT R0,SAV OFF,YVX OFF,YVT ON,DSP OFF,SEL ALL,XPOS 0,YPOS 0,XVAR 0,REDUCED
OFF,FULL OFF,PENUP 0,MULSOURCE OFF,MULRESULT OFF,PLOTTIME 20,SCREENPLOT ANALOG,R
XPOS 0,RYPOS 0,RXVAR 0,MSC AUX,POS R0,EXP 1,SET INACTIVE,MGN 1,WR
T ON,DOT OFF,LCK OFF,DSP ON,CLR OFF,XPOS 0,XVAR 0,FULL OFF,RXPOS 0,RXVAR 0,MENU
17,ERROR 82 :!# * * * * AUTO SET BUSY * * * * *
* *
SERIAL POLL: 0
*****
COMMAND: ?

```

Example: (HP85)

When the program is executed, first some interface parameters are set: the SPR is set to LF and the USP to / (slash).

The controller will then ask you to give your command.

next command: ?

Then you can enter your command and after typing a return, the oscilloscope returns its statusword and/or the data you asked for.

```
REPLY=
MSC R0/INV OFF/POS CAL/PLT R0/S
AV OFF/YVX OFF/YVT ON/DSP ON/SEL
ALL/XPOS 0/YPOS 0/XVAR 0/REDUCE
D OFF/FULL ON/PENUP 0/MULSOURCE
OFF/MULRESULT OFF/PLOTTIME 20/PL
OTTER PM8155/SCREENPLOT ANALOG/R
XPOS 0/RXPOS 0/RXVAR 0/PLOTSIZE
1.0/SET INACTIVE/MSC R1/INV OFF/
POS CAL/PLT R0/SAV OFF/YVX OFF/Y
VT ON/DSP OFF/SEL ALL/XPOS 0/YPO
S 0/XVAR 0/REDUCED OFF/FULL OFF/
PENUP 0/MULSOURCE OFF/MULRESULT
OFF/PLOTTIME 20/PLOTTER PM8155/S
CREENPLOT ANALOG/RXPOS 0/RXPOS 0
/RXVAR 0/PLOTSIZE 1.0/SET INACTI
VE/MSC R2/INV OFF/POS CAL/PLT R0
/SAV OFF/YVX OFF/YVT ON/DSP OFF/
SEL ALL/XPOS 0/YPOS 0/XVAR 0/RED
UCED OFF/FULL OFF/PENUP 0/MULSOU
RCE OFF/MULRESULT OFF/PLOTTIME 2
0/PLOTTER PM8155/SCREENPLOT ANAL
OG/RXPOS 0/RXPOS 0/RXVAR 0/PLOTS
IZE 1.0/SET INACTIVE/MSC R3/INV
OFF/POS CAL/PLT R0/SAV OFF/YVX 0
FF/YVT ON/DSP OFF/SEL ALL/XPOS 0
/YPOS 0/XVAR 0/REDUCED OFF/FULL
OFF/PENUP 0/MULSOURCE OFF/MULRES
ULT OFF/PLOTTIME 20/PLOTTER PM81
55/SCREENPLOT ANALOG/RXPOS 0/RYP
OS 0/RXVAR 0/PLOTSIZE 1 0/SET IN
ACTIVE/MSC AUX/POS R0/EXP 1/MGN
1/WRT ON/DOT OFF/LCK OFF/DSP ON/
CLR OFF/XPOS 0/XVAR 0/FULL OFF/R
XPOS 0/RXVAR 0/MENU 17/ERROR 82/
* * * * * AUTO SET BUSY * *
```

8.4 Programming examples

Following examples can be typed in, using the driver program or as a defined sequence in an other program.

8.4.1 Text

Figure 8.1 Text on the screen.

How to perform to get text on the top line of the oscilloscope screen.

<u>Command:</u>	<u>Comment:</u>
SPL SERVICE	Select main function SERVICE.
TEXT_MODE TOP	Select the TOP text area of the textpage. The default page selection is always page 0.
SPL TEXT	Select main function TEXT.
CHAR 7	Set the characters in high intensity.
LINE 0	Select line 0
COLUMN 0	Select column 0, (upper left corner).
TEXT FIRST LINE	The text "FIRST LINE" appears in the upper left corner of the screen in high intensity mode. The actual cursor position is now line 0, column 10.

We can continue now by selecting the next textline (line 2) and then select page 1.

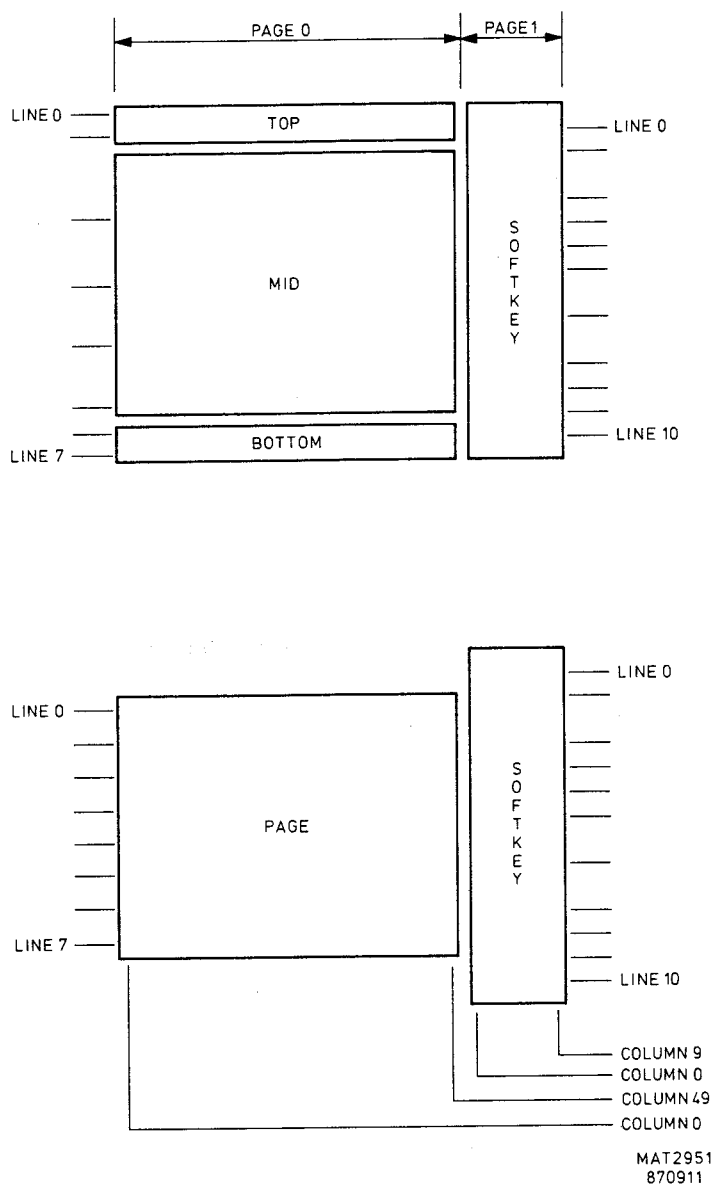
LINE 1	Select line 1.
TEXT SECOND LINE	Note that the actual cursor position was line 0, column 10. We increased the line position to line 1, so the text will appear on line 1, column 10. The actual cursor position is now line 1, column 21.
PAGE 1	We select now the other page (softkey-page). Note that the normal oscilloscope softkey text remains.
LINE 0	Select line 0.
COLUMN 0	COLUMN 0.
TEXT SOFTKEY AREA	Enter the text "SOFTKEY AREA".

The text is "hidden" and can now be made visible by sending:

SPL SERVICE	Select main function SERVICE.
TEXT_MODE SOFTKEY	Select the softkey text area of the selected page.

If we want to display more text on this softkey-page, we can enter:

SPL TEXT	Select main function TEXT.
TEXT WHATEVER YOU WANT	The text "WHATEVER YOU WANT" is chained to the previous text "SOFTKEY AREA".

You can now continue entering text, until all the 10 available lines in the softkey text area are filled up. The text continues then on the first line, column 1.

Let's go back to the other available page (PAGE 0) and see what the influence is of selecting the four text modes TOP, MID, BOTTOM and PAGE.

We are still in the TEXT_MODE TOP.

There are only two textlines available. The text is not wrapped around if the second line is filled, but the text is put in the next available textline (line 2) which is not displayed at this moment.

So if you enter

PAGE 0	Select page 0.
LINE 1	Select line 1.
COLUMN 0	Select column 0.

TEXT THIS IS A VERY LONG TEXT TO
DEMONSTRATE THE WRAP AROUND

You will see displayed the text until the WR. The rest of the text seems to be disappeared. But we can make it visible by entering following:

SPL SERVICE	Select main function SERVICE.
TEXT_MODE MID	Select the MID text area.

The rest of the text ... AP AROUND is visible on line 2.

NOTE: There are 8 lines of text available over the total page 0.

Selecting TEXT_MODE TOP enables to see line 0 and 1.
Selecting TEXT_MODE MID enables to see line 2, 3, 4 and 5.
Selecting TEXT_MODE BOTTOM enables to see line 6 and 7.
Selecting TEXT_MODE PAGE enables you to see all 8 textlines. Here you can use the wrap around feature.

8.4.2 Data transfer

To get data point from a trace out of the instrument to a controller, you have to use at least following instructions.

<u>Command :</u>	<u>Comment :</u>
REG 0	Select the register where the trace is stored which you want to transfer.
MSC TRACE	Select the main function TRACE.
INTF IEEE488.0	Select the interface via which you want to transfer the data.
DATA_TYPE DECIMAL	Select the way you want to interpret the data.
DAT ?	Forces the oscilloscope to send the data via the selected interface to the controller.

In the above situation you will get all 4096 data points via the IEEE interface to the controller. In the data transfer programs you are going to write, you have to accept the incoming data.

Whether you do this in an array or you put it into a sequential file on one of the available media on your controller (DISK, RAM, TAPE) is up to you, and is of course controller depending.

Entering above described sequence in one of the IEEE driver programs will display all data points on the screen in decimal format.

8.4.3 Dumping data to a printer (serial printer)

You can directly connect a printer to the oscilloscope and use this printer as a kind of log-device for all your IEEE commands.

<u>Command :</u>	<u>Comment :</u>
SPL INTERFACE	Select the main function INTERFACE.
INTF RS232_OUT.0	}
STOP 2	}
DATA 8	}Set the serial parameters
PARITY NO	}
BAUDRATE 1200	}
DESTINATION RS232_OUT.0	All data you ask for will be send to the serial interface.

Now you can give commands via your IEEE driver program, and the results will be printed on the printer.

For example if you type now:

```
VER ?                               Force the oscilloscope to send
                                     all the vertical settings.
```

All the vertical settings will be printed on the connected printer.

8.4.4 Use of UP/DOWN/NORMAL + URQ

Sending ATT UP to the oscilloscope will increase the sensitivity of the selected channel. This increase will continue, until ATT NORMAL is send.

Following program shows how to use this feature.

Every time you press the URQ button on the front of the oscilloscope, the status is changed, UP, NORMAL, DOWN, NORMAL, UP, NORMAL etc.

```
580 CLS
590 ' START APPLICATION PROGRAM AFTER THIS LINE
600 '
610 AD=708 'scope adress=8
620 ADP=7 'adapter nr=7
630 SC=1 'adapter is sytem controller
640 CON=7:STATUS=30
650 MAX=255
660 TIME=50
670 CALL IOABORT(ADP)
680 CALL IORESET(ADP)
690 CALL IOINIT(AD,SC)
700 CALL IOCLEAR(AD)
710 CALL IOTIMEOUT(ADP,TIME)
720 CALL IOCONTROL(ADP,CON,STATUS)
730 PRINT "*****"
740 INPUT "when ready, type return";A$
750 CLS
760 WR$="ver a,att up":LE=LEN(WR$)
770 PRINT "ATT IS STEPPING UP"
780 CALL IOOUTPUTS(AD,WR$,LE)
790 GOSUB 1000
800 IF STATUS<>64 THEN 790
810 WR$="att normal":LE=LEN(WR$)
820 PRINT "ATT IS STOPPED"
830 CALL IOOUTPUTS(AD,WR$,LE)
840 GOSUB 1000
850 IF STATUS<>64 THEN 840
860 WR$="ver a,att DOWN":LE=LEN(WR$)
870 PRINT "ATT IS STEPPING DOWN"
880 CALL IOOUTPUTS(AD,WR$,LE)
890 GOSUB 1000
900 IF STATUS<>64 THEN 890
910 WR$="att normal":LE=LEN(WR$)
920 PRINT "ATT IS STOPPED"
930 CALL IOOUTPUTS(AD,WR$,LE)
940 GOSUB 1000
950 IF STATUS<>64 THEN 940
960 GOTO 760
970 REM *****
980 IF PCIB.ERR<>0 THEN PRINT PCIB.ERR$
990 RETURN
1000 REM ***** SERIAL POLL *****
1010 FOR Q=1 TO 100:NEXT Q
1020 CALL IOSPELL(AD,STATUS)
1030 IF STATUS = 97 THEN PRINT "PROGRAMMING ERROR"
1040 IF STATUS =98 THEN PRINT "INTERNAL ERROR"
1050 GOSUB 980
1060 RETURN
```

There are more functions where you can use this feature: time base, offset, trigger delay, plottime etc.

8.4.5 Front settings

To demonstrate the use of the different front setting possibilities it is advised to insert a line in the driver programs. The oscilloscope remains then in local mode. Now you can change also some front settings by hand.

For the HP85 program : insert line 20 LOCAL 7
 For the IBM program : insert line 735 CALL IOLOCAL(AD)

We are going to fill front 1.00 and front 5.00.

Following steps show how to perform:

<u>Command:</u>	<u>Comment:</u>
SPL SETMEM	Select the main function SETMEM.
FRONT 1.00	Select front 1.00. (It is possible that you get an error message on the screen).
SETTING SAVE	Now the actual front is saved in FRONT 1.00.

You can change now the front panel settings by hand, and save the next front by typing:

SETTING INSERT	Selects the next subfront and saves the setting (subfront 1.01).
----------------	--

Change the front panel setting and type:

SETTING INSERT	Selects the next subfront and saves the setting (subfront 1.02).
----------------	--

SETTING INSERT	Selects the next subfront and saves the setting (subfront 1.03).
----------------	--

etc.	etc.
------	------

FRONT 5.00	Select front 5.00.
------------	--------------------

SETTING SAVE	The actual front is saved in front 5.00 now.
--------------	--

You can follow the same procedures as described before for front 1.00.

Now enter:

SETTING PREVIOUS	The fronts, as you entered them in front 5.00 ... 5 ... are displayed in sequence until
SETTING NORMAL	is send.
FRONT DOWN	Stepping down in the subfronts until front 5.00 is reached.
FRONT NORMAL	Ends the down stepping sequence.
FRONT 1.00	Select front 1.00.
SETTING PREVIOUS	All sub fronts in front 1 are displayed until
SETTING NORMAL	is send.
SETTING EOS	Clears all subfronts of front 1.
FRONT 5.00	Select front 5.00.
SETTING EOS	Clears all subfronts of front 5.

8.4.6 Register savings

You can copy trace data from one register to another.

Example to copy the register R0 contents to all the other 3 registers R1, R2 and R3:

<u>Command:</u>	<u>Comment:</u>
MSC AUX	Select main function MSC AUX.
DSP ALL	Display all four registers.
EXP 3	Display Y/5.
MSC R1	Select main function register R1.
SAV ON	The sequence (SAV ON, SAV OFF) copies the contents of R0 to R1.
SAV OFF	
MSC R2	Select main function register R2.

SAV ON	The sequence (SAV ON, SAV OFF) copies the contents of R0 to R2.
SAV OFF	
MSC R3	Select main function register R3.
SAV ON	The sequence (SAV ON, SAV OFF) copies the contents of R0 to R3.
SAV OFF	
MSC AUX	Select main function MSC AUX.
DSP OFF	Switch the display of all four registers off.
EXP 1	Display Y*1 again.

8.4.7 EVENT counting and trigger level for events

Connect a signal to the channel A and the EXTERN input sockets.

Following steps can be programmed:

<u>Command:</u>	<u>Comment:</u>
HOR MTB	Select main function HOR MTB.
EVT ON	Set events on.
MSC AUX	Select main function MSC AUX.
MENU 22	Select menu 22, events menu.
HOR MTB	Select main function HOR MTB.
TSO A	Select trigger source channel A.
LEV VAR	Set level to variable.
LEV	Change the trigger sensitivity by sending LEV followed by a decimal value until the signal triggers.

Then continue by entering:

TRD 300	Select trigger delay 300.
TRD 500	Select trigger delay 500.
TRD 1000	Select trigger delay 1000.
TRD 4000	Select trigger delay 4000.

to see the change in the event-counting.

8.4.8 Plotting register 0, using a controller.

In this example, by using one of the driver programs, plotting is performed on a serial plotter.

Following set-up is assumed.

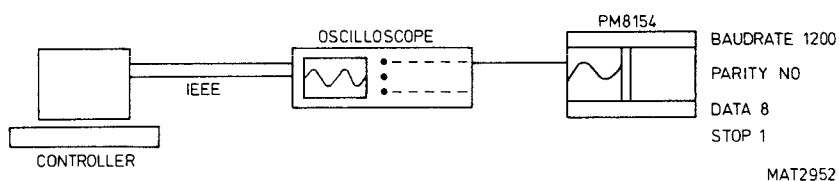

Figure 8.2 Plotter set-up.

Set the parameters of the serial interface to the plotter in the oscilloscope.

Command:

Comment:

```
FRO 0
SPL INTERFACE
INTF RS232 OUT.0
BAUDRATE 1200
PARITY NO
DATA 8
STOP 1
```

Set the interface parameters.

Set the plotter parameters (plotter, size).

Command:

Comment:

```
MSC R0
PLT R0
PLOTTER PM8154
PLOTSIZE 0.5
```

Register 0 will be plotted.
Plotter selection.
Set the desired plotsize.

Select the interface and plot.

Be sure that the plotter is well connected to the oscilloscope and is really standby.

Command:

DESTINATION RS232_OUT.Ø

Comment:

This command defines the serial interface as destination for the plotter commands.
In fact, this command is the same as pressing RS232 in the digital plotter select menu.

PLT DIGITAL

Plotting is started.

In case you want to see a screen plot, you type SCREENPLOT DIGITAL instead of PLT DIGITAL.

A PLOT OFF will stop the plotting.

NOTE:

Plotting in the above described way; controlling the scope via IEEE, and plotting via the serial interface, can only work when the oscilloscope is in local mode. When you use the driver programs, please insert the program lines as described below to keep the scope in local mode.

IBM : insert line 735 CALL IOLOCAL (AD)
HP85: insert line 20 LOCAL 7

8.4.9 Bus learn

The program below illustrates how the BINPROG command should be used.

```

10REM *****
20      BINPROG EXAMPLE FOR IBM
60      REL DATE:88-07-07
70      SOFTWARE SUPPORT GROUP
80REM *****
.
.      DECLARATION PART IEEE CARD
.
.
600
610 AD=708 ^scope adress=8
620 ADP=7 ^adapter nr=7
630 SC=1 ^adapter is system controller
640 CON=7:STATUS=30
650 MAX1=189:MAX2=191
660 TIME=15
670 CALL IOABORT(ADP)
680 CALL IORESET(ADP)
690 CALL IOINIT(AD,SC)
700 CALL IOTIMEOUT(ADP,TIME)
710 CALL IOCONTROL(ADP,CON,STATUS)
720 PRINT"*****"
730 CALL IOLOCAL(AD)
740 LINE INPUT "COMMAND: ";WR$
    
```

```

750 IF LEFT$(WR$,2)="st" OR LEFT$(WR$,2)="ST" THEN 870
760 IF LEFT$(WR$,2)="bi" OR LEFT$(WR$,2)="BI" THEN 900
770 IF LEFT$(WR$,2)="ba" OR LEFT$(WR$,2)="BA" THEN 1040
780 GOTO 730
790 REM ***** SERIAL POLL *****
800 FOR Q=1 TO 100:NEXT Q
810 CALL IOS POLL(AD,STATUS)
820 PRINT "SERIAL POLL: ",STATUS
830 IF STATUS = 97 THEN PRINT "PROGRAMMING ERROR"
840 IF STATUS = 98 THEN PRINT "INTERNAL ERROR"
850 IF PCIB.ERR <> 0 THEN PRINT PCIB.ERR$
860 RETURN
870 REM ***** END OF PROGRAM *****
880 CALL IOLOCAL(AD)
890 CLS:END
900 REM ***** BINPROG TO CONTROLLER *****
910 WR$="BINPROG ?"+CHR$(10)
920 LE=LEN(WR$)
930 CALL IOOUTPUTS(AD,WR$,LE)
940 GOSUB 790
950 INFO$=SPACE$(MAX1):RDNR=0
960 CALL IOENTERS(AD,INFO$,MAX1,RDNR)
970 PRINT LEFT$(INFO$,RDNR);
980 B1$=LEFT$(INFO$,RDNR)
990 INFO$=SPACE$(MAX2):RDNR=0
1000 CALL IOENTERS(AD,INFO$,MAX2,RDNR)
1010 PRINT LEFT$(INFO$,RDNR);
1020 B2$=LEFT$(INFO$,RDNR)
1030 GOTO 730
1040 REM ***** BINPROG TO SCOPE *****
1045 IF B1$="" THEN PRINT "NOTHING TO SEND.....": GOTO 720
1050 B1$=LEFT$(B1$, (LEN(B1$)-1))
1060 LE=LEN(B1$)
1070 CALL IOOUTPUTS(AD,<BI>B1$<D>,LE)
1080 GOSUB 790
1090 B2$=LEFT$(B2$, (LEN(B2$)-1))
1100 LE=LEN(B2$)
1110 CALL IOOUTPUTS(AD,B2$,LE)
1120 GOSUB 790
1130 GOTO 730

```



9. CHARACTERISTICS OF IEEE-488/IEC-625, RS232-C/V24 INTERFACES AND REAL TIME CLOCK

CHARACTERISTICS	SPECIFICATION	ADDITIONAL INFORMATION
9.1	Type of interface	ANSI/IEEE Std.488-1978
	-Connector	Amphenol Type 57LE-20240 7700035C Or similar intermating with Amphenol 57FE Series receptacles. Rfi/EMI shielded.
	-Bus drivers	E2 Three-state (true = 0..0,8 V; false is 2...5 V)
	-Interfacing	
	Function Repertory:	
	Source handshake	SH1 Complete capability
	Acceptor handshake	AH1 Complete capability
	Talker	T5 Basic Talker : Yes Serial Poll : Yes Talk Only : Yes Unaddress if MLA : Yes
	Listener	L3 Basic Listener : Yes Listen only : Yes Unaddress if MTA : Yes
	Service Request	SR1 Complete capability
	Remote Local	RL1 No Local Lock-out
	Parallel Poll	PP0 No capability
	Device clear	DC1 Complete capability
	Device trigger	DT1 Complete capability
	Controller	CO No capability
	-Address:	0...30 Software settable, through Soft-keys and Menu.
	Indicator	CRT In soft-key area
	Default address	8 At delivery or after Switching-On without Back- up Battery
	-Timing:	
	Source Handshake	See fig. 4.6.
	First source Time (Tsc1)	
	Binary :	150 ms or less } extra time between data
	Decimal:	150 ms or less } blocks 180 us.
	Source time (Tsc)	
	Binary :	6 us or more
	Decimal:	10 us or more
	Acceptor handshake	See fig. 4.6.

CHARACTERISTICS	SPECIFICATION	ADDITIONAL INFORMATION
Accept time (T _{ac})		
Binary :	1 us or less	
Decimal :	1 us or less	
Ready time (T _{rd})		
Binary :	6 us	
Decimal :	10 us	
9.2 Type of interface	RS 232-C	
-Connector	MIL-C-24308	25 Pole male connector RFI-EMI shielding
-Bus Drivers:		
Data circuits:		
Spacing "0"	> + 3 V	} }Txd and RxD lines
Spacing "1"	< - 3 V	}
Control units:		
ON	> + 3 V	}RST, CTS, DSR and DTR }lines
OFF	< - 3 V	}
Current output	< 10 mA	
Impedance		
Output	300 ohm	
Input	> 3 kohm < 7 kohm	
Voltage:		
Output	> - 7 V < + 7 V	
Input	> - 25 V < + 25 V	
-Interfacing function Repertory:		
BAUD-RATE	75, 110, 150, 300, 600, 1200, 2400, 4800, 9600, 19200	Input and Output separately selectable
Number of STOP-bits	1 or 2	
Parity	Odd, Even or No	
Character length	7 or 8	
Transmission mode	Asynchrone, full duplex	
Handshake:		
Software	XON/XOFF	
Hardware	DSR/DTR and CST/DTR	
Serial Poll	ESC 7	ESC is HEX 1B or Decimal 27

CHARACTERISTICS	SPECIFICATION	ADDITIONAL INFORMATION
Go to Remote	ESC 2	
Go to Local	ESC 1	
Device Clear	ESC 4	
Device Trigger	ESC 8	
Local lock out	ESC 5	
9.3 Real time clock		Adjustable through keyboard
-Inaccuracy	< 100 ppm	
9.4 Front panel control		
-Modes	Local	Front panel exclusively under manual control, remote led; off
	Remote-locked	Front panel exclusively under IEEE 488 or RS232-C, remote led; on
-Push buttons	Command and Question	Except ON/OFF switch
-Continuous controls	Command and Question	Except CRT controls
	center: resolution:	
X-position	0	4096
Y-position (/5)	0	2048
Y-position (x1)	0	2048
Y-position (x5)	0	1280
X-variable	0	256
Shift	512	1024
Y-variable	0	512
Level	256	512
-Probe identification	Question only	Except in register super function
9.5 Text on CRT-control	Command and Question	
-Modes	Text only	
	Text combined with:	
	Signal trace	In any combination
	Settings read-out	
	Cursors	
-Number of pages	2	
-Number of lines of pages	8	
-Number of characters per line	50	Including Blanks

CHARACTERISTIC	SPECIFICATION	ADDITIONAL INFORMATION
9.6	Cursor control	Command
		Cursor Read-out automatically updated when cursors are set by IEEE 488 or RS232-C bus.
		Question
	-Resolving power:	Cursor position can be sent to controller
		Absolute Setting on Screen (equals 10 div. hor. or 8 div. vert. or 100%)
	Fully to the Right of graticule	0
	Fully to the Left of graticule	+4095
	Center of graticule	+2048
9.7	Digital output:	
	Plotter language	Compatible with HPGL and PHILIPS
	Plotter language	Compatible with EPSON (FX80) and HP Thinkjet

10. SERVICE INFORMATION

10.1 BLOCK DIAGRAM AND MEMORY MAP

Figure 10.1 shows a block diagram of the IEEE-488/RS232-C interface.

The interface consists of:

- A 68000 MICROPROCESSOR with (EP)ROM and RAM.
- An RS232-C INTERFACE.
- A REAL TIME CLOCK circuit.
- An IEEE-488 INTERFACE.
- A BUS ARBITER circuit.
- BUFFERS to the CCU-bus of the oscilloscope.
- Various decoding and control logic.

The IEEE-488 INTERFACE, the RS232-C INTERFACE and the REAL TIME CLOCK can generate an interrupt to the microprocessor.

The memory map is given on the next page.

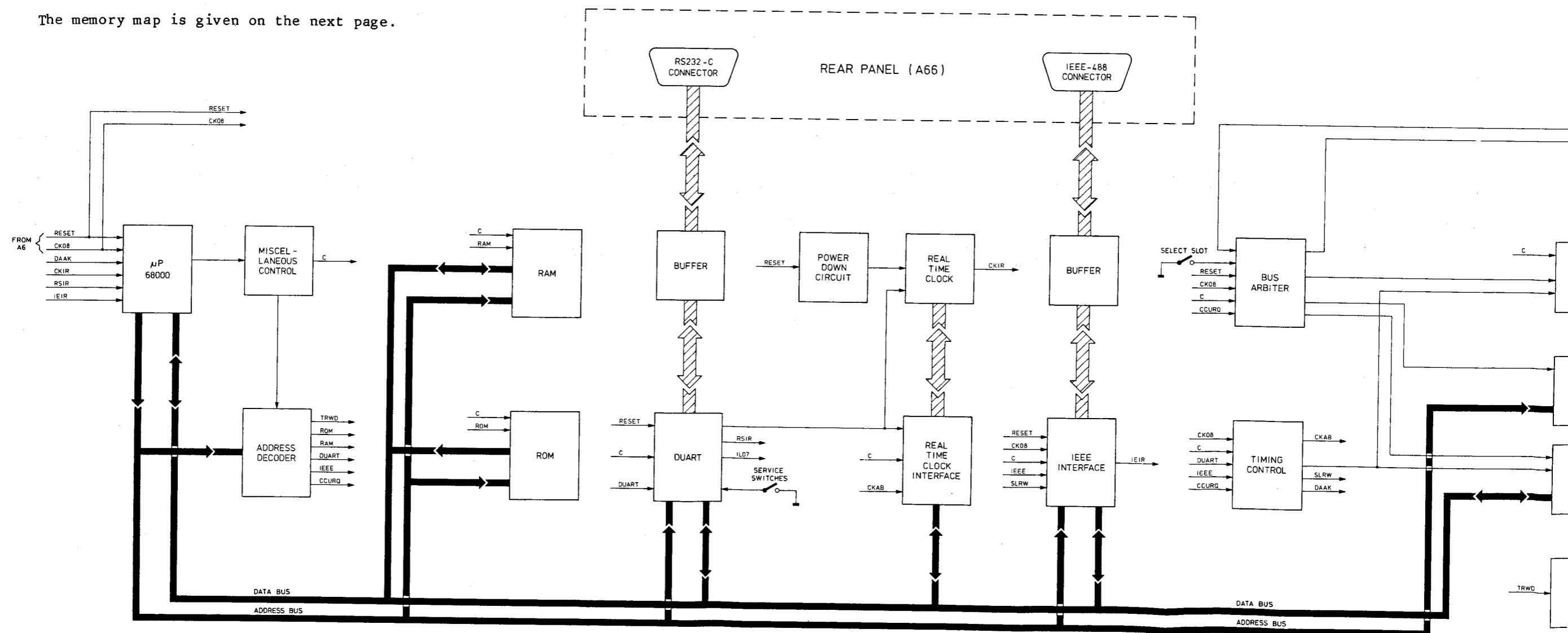

Figure 10.1 Block diagram of IEEE-488/RS232-C interface.

TION

ND MEMORY MAP

ws a block diagram of the IEEE-488/RS232-C interface.

nsists of:

- MICROPROCESSOR with (EP)ROM and RAM.
- C INTERFACE.
- IME CLOCK circuit.
- IEEE-488 INTERFACE.
- BITER circuit.
- to the CCU-bus of the oscilloscope.
- decoding and control logic.

INTERFACE, the RS232-C INTERFACE and the REAL TIME CLOCK interrupt to the microprocessor.

is given on the next page.

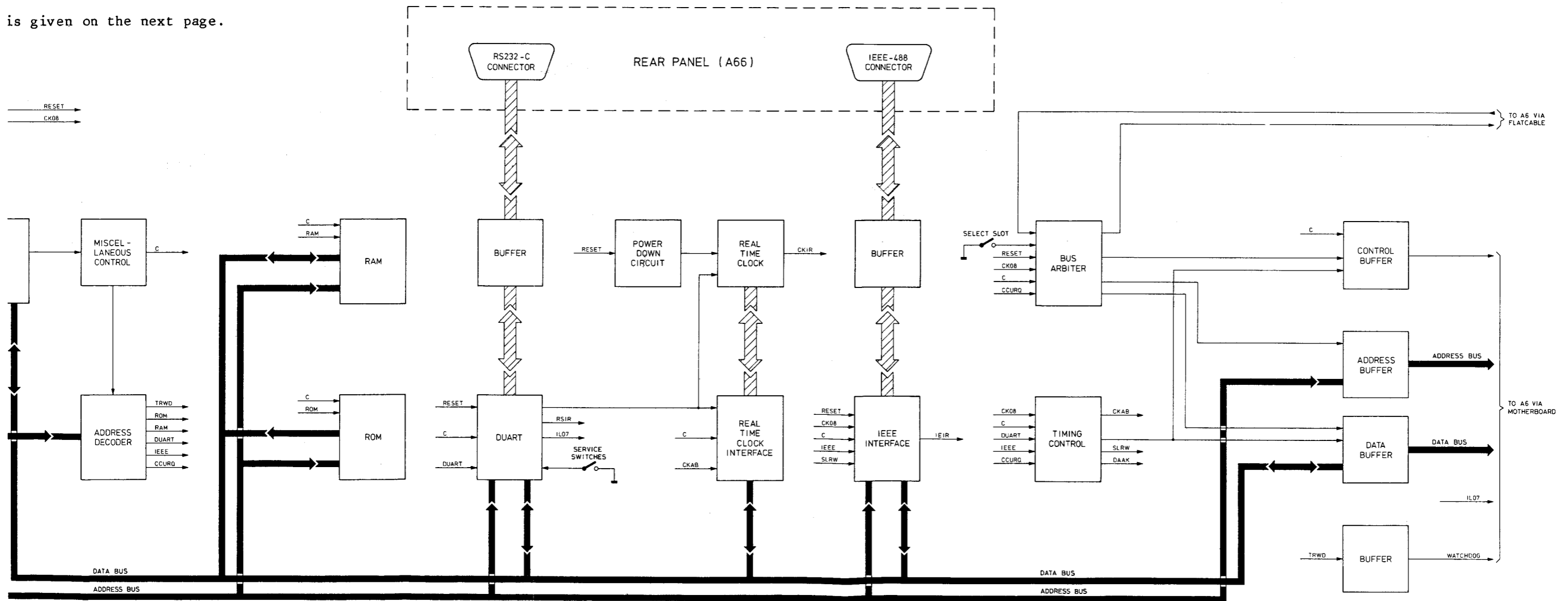

Block diagram of IEEE-488/RS232-C interface.

10. SERVICE INFORMATION

10.1 BLOCK DIAGRAM AND MEMORY MAP

Figure 10.1 shows a block diagram of the IEEE-488/RS232-C interface.

The interface consists of:

- A 68000 MICROPROCESSOR with (EP)ROM and RAM.
- An RS232-C INTERFACE.
- A REAL TIME CLOCK circuit.
- An IEEE-488 INTERFACE.
- A BUS ARBITER circuit.
- BUFFERS to the CCU-bus of the oscilloscope.
- Various decoding and control logic.

The IEEE-488 INTERFACE, the RS232-C INTERFACE and the REAL TIME CLOCK can generate an interrupt to the microprocessor.

The memory map is given on the next page.

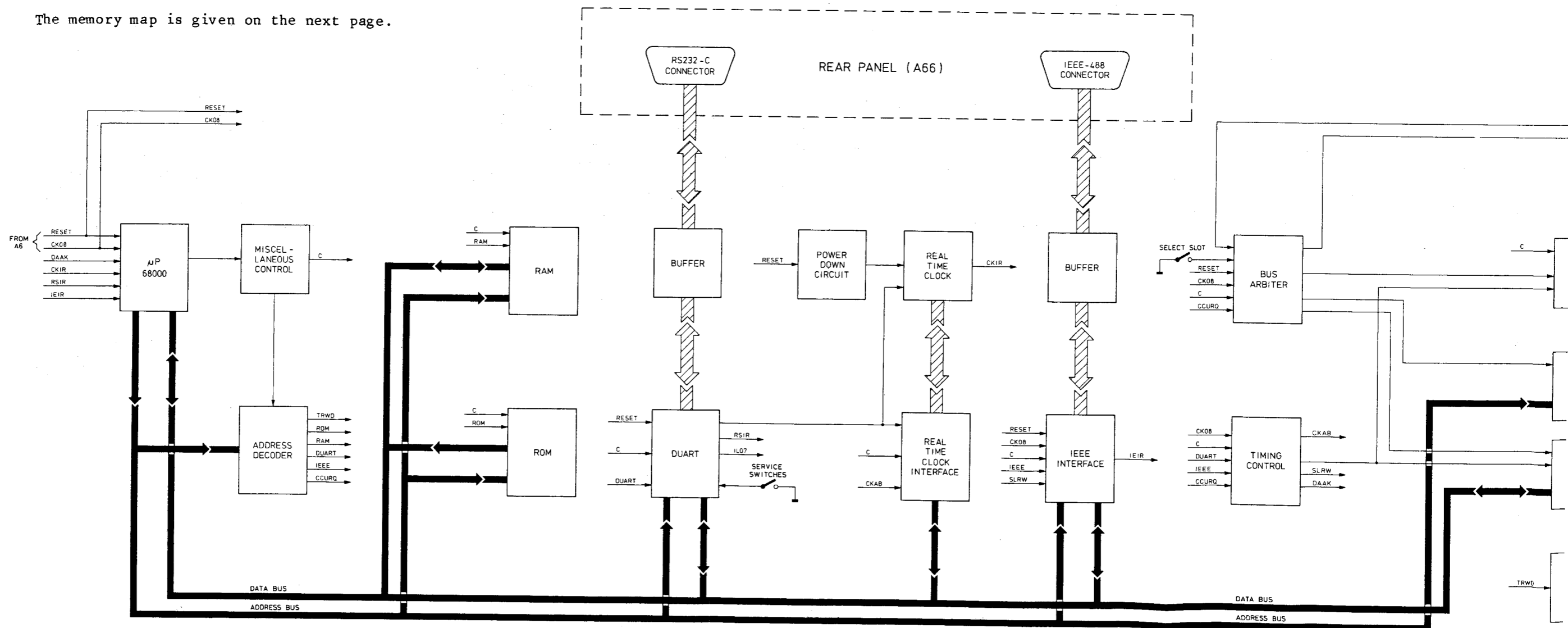

Figure 10.1 Block diagram of IEEE-488/RS232-C interface.

When the address range 80000-FFFFFF has to be accessed, address line 23 (UPAB23) goes high, which means that the CCU-bus has to be accessed. If the microprocessor is allowed to access the CCU-bus, the bus arbiter enables the DATA BUS BUFFER and the ADDRESS BUS BUFFER. Normally the buffers separate the CCU-bus from the microprocessor bus. To detect whether a microprocessor is allowed to access the CCU-bus, the bus arbiters communicate via four lines. Three of them are a open collector wired-or circuit: BSBU--LT, BSRQ--LT and MASL--LT. These lines can be pulled down by each arbiter circuit, but also each arbiter circuit can detect the level of the line. The fourth line is an output of the bus arbiter on unit A6 (BSGROT) and an input to unit A7 (BSGRIN).

The assignment of the CCU-bus to a microprocessor operates as follows (see figure 10.3):

Starting point: A6 accesses the CCU-bus; therefore it pulls BSBU--LT low.

A7 wants to access the CCU-bus.

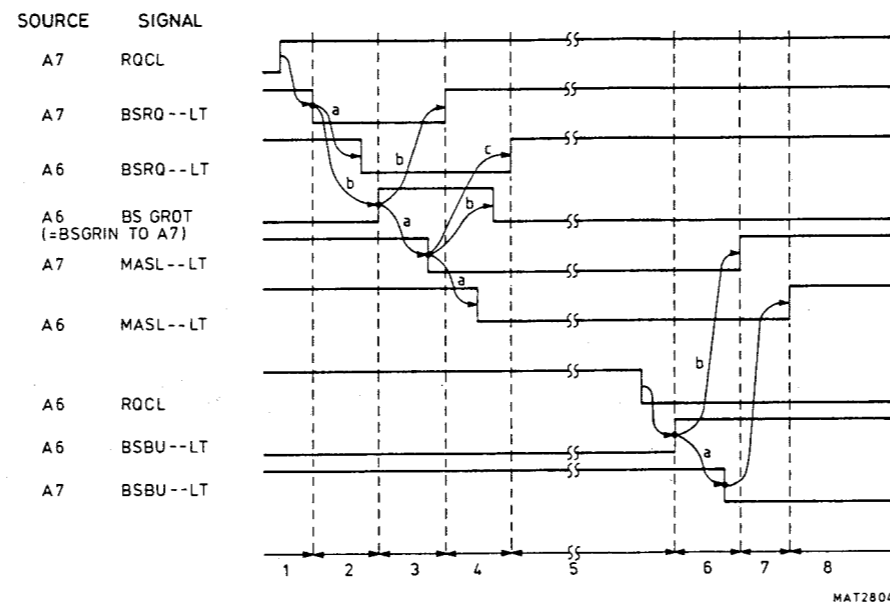

Figure 10.3 Timing diagram of CCU-bus assignment.

Now the next happens:

1. Because A7 wants to access the CCU-bus it generates a RQCL to the bus arbiter. The bus arbiter of A7 pulls BSRQ--LT down, which is detected by the BSRQ--LT input of A6.
- 2a. A6 pulls BSRQ--LT low.
- 2b. A6 makes BSGROT high, which is detected by BSGRIN on A7.
- 3a. A7 pulls MASL--LT low, which is detected by the MASL--LT input of A6.
- 3b. A7 releases BSRQ--LT, but this line stays low because A6 still pulls it low.
- 4a. A6 pulls MASL--LT low.
- 4b. A6 makes BSGROT high.
- 4c. A6 releases BSRQ--LT. Now this line goes high.

MEMORY MAP

Only a part of the complete address range is used, as following memory map which also gives the memory sele

Address (Hex)

000000

03FFFF

040000

040001

07FFFF

080000

09FFFF

0A0000

0BFFFF

0C0000

0C001F

0C0020

0FFFFFF

100000

10000F

100010

7FFFFFF

800000

FFFFFF

ROM
TRWD
Not used
RAM
Not used
DUART
Not used
IEEE
Not used
Outside interface

MEMORY MAP

Only a part of the complete address range is used, according to the following memory map which also gives the memory select signals.

Address (Hex)

000000	ROM
03FFFF	
040000	TRWD
040001	
07FFFF	Not used
080000	
09FFFF	RAM
0A0000	
0BFFFF	Not used
0C0000	
0C001F	DUART
0C0020	
0FFFFFFF	Not used
100000	
10000F	IEEE
100010	
7FFFFFFF	Not used
800000	
FFFFFFF	Outside interface

The whole sequence as just described (the arbiter cycle) is handled very fast. It takes less time than a read or write action of the microprocessor on unit A6, so BSBU--LT is still kept low by A6 as this sequence is finished.

When the microprocessor on unit A6 has finished reading or writing on the CCU bus (e.g. to get the next instruction from rom) it makes RQCL low (5).

Now the sequence continues as follows:

5. A6 releases BSBU--LT. Now this line goes high, which is detected by the BSBU--LT input of A7.
- 6a. A7 pulls BSBU--LT low, which is detected by the BSBU--LT input of A6.
- 6b. A7 releases MASL--LT, but this line stays low because A6 still pulls it low.
7. A6 releases MASL--LT. Now this line goes high.

Now A7 accesses the CCU bus and BSBU--LT is low.

NOTE: If A6 wants access the bus, it does not generate RQCL to start an arbiter cycle, but it waits until BSBU--LT goes high and MASL--LT is high. Then it takes over the CCU-bus.

10.3 EXPLANATION OF SIGNAL NAMES

Signal names consist of 2 parts:

- a functional part of maximal 6 characters
- a realisation part of 2 characters

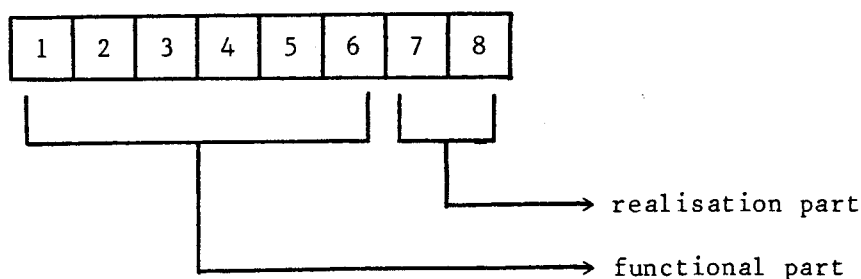

The realisation part is optional. If it is used then the functional parts should consists of 6 characters. If necessary dummy's (minus signs) are used in the functional part, to make it 6 characteres long.

The realisation part has the following meaning:

- HT: active high signal TTL level
- LT: active low signal TTL level

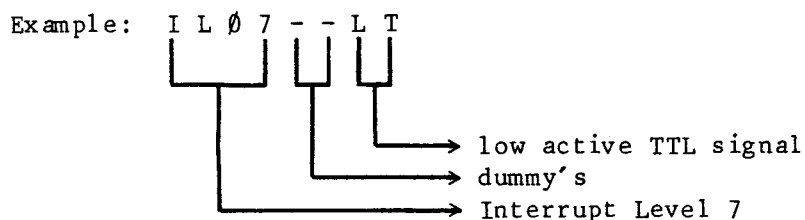

Behind the circuit description, a list with the signal names used in the unit is given in alphabetical order. Behind each name, a description is given and is mentioned on which unit the signal is generated. Only if the signal is generated on this unit, the other units on which the signal is used are mentioned, otherwise a minus sign is filled in. If the signal flows over more units in sequence, the path is indicated.

Some signals may have more signal sources, because the sources have open collector output circuits, or 3-state output circuits. In this case the sources are mentioned, separated with a plus (+) sign. As signal source is always indicated, the unit where the signal is generated.

The destinations of the data-bus and address-bus lines from the microprocessor on unit A6 (CCU bus) are indicated with "general", because almost all units are involved. This is also done for the signals UPRD--LT (microprocessor read) and UPWR--LT (microprocessor write).

10.4 CIRCUIT DESCRIPTION

The MICROPROCESSOR (D101) gets its clock signal and a reset from the logic of unit A6 via the RESET AND CLOCK CIRCUIT. The clock frequency is 8 MHz.

The reset signal (UPRSOTLT) is also connected to testpoint X713, which is located next to ground testpoint X716. By interconnecting these testpoints, the microprocessors of the oscilloscope and the option can be restarted.

The "data acknowledge" signal, which is needed for the asynchronous bus structure of the 68000 microprocessor, is generated by several open collector output circuits, which are connected in wired-or configuration.

For the circuits on this unit the ON CARD DAAK GENERATION generates the DAAK--LT signal.

The microprocessor can be interrupted (in order of increasing priority level) by the REAL TIME CLOCK (CKIR--LT), the RS232-C INTERFACE (RSIR--LT) and the IEEE-488 INTERFACE (IEIR--LT).

The MISCELLANEOUS CONTROL circuit generates various data strobe and address strobe signals.

The ON CARD ADDRESS DECODER generates 4 select signals (ROM---LT, RAM---LT, DUART-LT and IEEE--LT) for hardware on this unit.

The TRWD--LT signal is led via the WATCHDOG BUFFER to the microprocessor board A6 to trigger the watchdog circuit on unit A6. This is done because the microprocessor on unit A6 does not trigger its own watchdog circuit, when the microprocessor of an option controls the CCU-bus.

The OFF CARD ADDRESS DECODER generates the CCURQ-LT signal to the bus arbiter to start an arbiter cycle, which is needed to let the microprocessor access the memory of the oscilloscope. This happens when UPAB23 goes high.

The two ROMs (ROM LOW BYTE and ROM HIGH BYTE) are selected by ROM---LT. The two RAMs (RAM LOW BYTE and RAM HIGH BYTE) are selected by RAM---LT. Jumper X722 permits selection between 8K or 32K rams. Normally the jumper is in position 2-3.

The RS232-C INTERFACE consists of a DUART (Dual Asynchronous Receiver and Transmitter, D128) and a BUFFER (D123 + D124). The DUART contains the logic required to perform data transfer conforming the RS232-C protocol for two channels. One channel is used for this purpose (channel A). The second channel (B) can be used for testing facilities via measuring points X710 and X711. The built in crystal driven (Z101) generator generates a frequency, which is divided down to the desired baud rate. The signals of both channels are buffered by the BUFFER. Some logic in the DUART is used to detect the position of the SERVICE SWITCHES (jumpers). X727 should always be in position 2-3. X728 and X729 are used to start up the diagnostic software. For normal operation they should be in position 2-3. The WDOT--LT signal from the DUART is not active in this option, but may be used in future expansions as a signal from an internal watchdog. Therefore the jumper X726 has no function. Normally it is set in position 1-2. The DUART is reset by the microprocessor reset signal from unit A6. One outputline (RSIR--LT) is used to interrupt the microprocessor.

The REAL TIME CLOCK CIRCUIT consists of a dedicated REAL TIME CLOCK IC (D127), a REAL TIME CLOCK INTERFACE (D129) and a POWER DOWN CIRCUIT (D126).

The REAL TIME CLOCK IC contains some ram and the logic to perform a time clock/calender function.

The ram is used for setting data (e.g. IEEE address or selected baud rates), because it is supplied by the battery at power down.

The time clock is crystal controlled (Z102).

Some control signals come from the DUART, which has some logic, that is used for address decoding.

The CKIR--LT signal is used to interrupt the microprocessor. The POWER DOWN CIRCUIT disables the real time clock IC to avoid unrequired writing by the microprocessor at power down. Power down is indicated by the MYSLDWLT signal from unit A6. The real time clock continues running on the battery power.

The real time clock IC has some ram and several registers for time or data that have to be addressed to perform reading or writing.

Addresses and data should be applied via a multiplexed bus (RTCMAD0...7). The REAL TIME CLOCK INTERFACE is used for this. For example reading a register operates as follows:

- First the address is latched in D129.
- Next the address is latched in D127 via a control line (RTCAS) from the DUART.
- Next the concerning register in D127 writes its data to the multiplexed bus due to the going low of the RTCRW-signal.
- The data are latched in D128.
- The data are read by the microprocessor.

Because the control signals which control this multiplexing sequence are generated via the microprocessor software, this is called software multiplexing.

The circuit is reset by the microprocessor reset signal from unit A6.

The IEEE-488 INTERFACE consists of a dedicated IEEE INTERFACE IC (D122) and a BUFFER (D117...D119 + D121).

The IEEE INTERFACE IC contains all the logic required to perform data transfer conforming the IEEE protocol.

It is clocked by the 8 MHz microprocessor clock. The circuit is reset by the microprocessor reset signal from unit A6.

One output line is used to interrupt the microprocessor (IEIR--LT). The BUFFER buffers all data and control lines.

The TIMING CONTROL generates various control signals. It consists of an FPLA (Field Programmable Logic Array D138) and a shift register (D137) to obtain delays. It is clocked by the 8 MHz microprocessor clock. The generated signals are used for the IEEE-488 INTERFACE (SWRDIELT and SWWRIELT) the REAL TIME CLOCK INTERFACE (CKAB and ENBA--LT) and the CCU-bus buffers (CCUWR-LT and CCURD-LT).

The BUS ARBITER consists of a dedicated IC (D142) with associated logic. It's main function is to assign control of the microprocessor bus (CCU bus) to the microprocessor that claims control of the microprocessor bus. The circuit is reset by the microprocessor reset signal from unit A6. The CCU-BUS timing delays time the taking over of the CCU-bus by somemicroprocessor. The SLOT SELECTOR selects the BSGRINHT or the BSGROTHT signal, depending on the position of jumper X723. The position of this jumper is selected, depending on the slot position of the interface. Normally the interface is installed in slot A7 and the BSGRINHT signal should be selected. Then jumper X723 should be in position 1-2. The CCU-READ DAAK GENERATION generates the data acknowledge signal when logic outside the interface is accessed via the CCU-bus. When this happens, the DATRAKLT signal is generated by the accessed logic. This signal enters the interface via X701 pin 308 and is applied via jumper X724 to the CONTROL BUFFER (D131). The output signal of this buffer (CCUTSMLT) generates via flipflop D134 (pins 10 and 8) the TSLMA-LT signal, which on it's turn generates via the BUS ARBITER the RQB signal. This signal generates DAAK--LT via flipflop D134 (pins 3 and 5) and gate D144 (pins 3 and 4). For use in stand alone mode the jumper X724 can be changed over, which results in generation of the DAAK--LT signal by CCUBSELT. This is not used in this option, so the jumper should be in position 1-2.

The BUFFERS consists of a CONTROL BUFFER (D131), an ADDRESS BUFFER (D132 + D133) and a DATA BUFFER (D139 + D141). They separate respectively the control lines, address lines and data lines of the microprocessor of the interface from the corresponding lines of the CCU-bus.

The numbering system of the connector pins is different from usual. On connector X701 pin nrs a1...a32 are numbered 101...132, pin nrs b1...b32 are numbered 201...232 and pin nrs c1...c32 are numbered 301...332.

The location of the pins of X702 and X704 is identical to the location of the pins of X723 on the interconnection board that is mounted on the IEEE-488 connector on the rear panel (see figure 9.4). The location of the pins of X703 is identical to the location of the pins of X721 on the interconnection board.

All RS232-C and IEEE-488 lines are led via an interconnection board to simplify installation of the interface. The table on the next page shows the interconnections on the board.

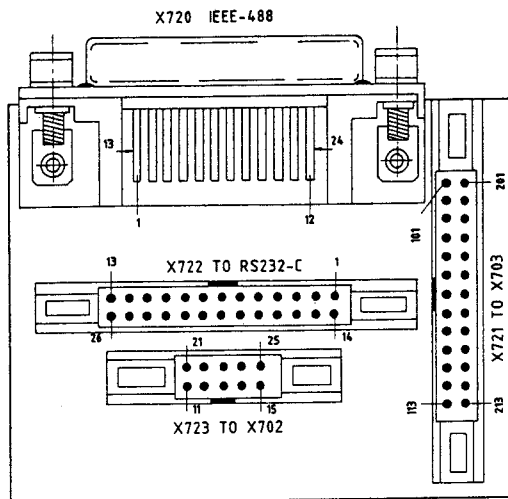

MAT 2842

Figure 10.4 Layout of the interconnection board.

Wiring list of IEEE-488 and RS232-C interconnection board.

Signal name	IEEE-488 X720	X721
DIO1	1	101
DIO2	2	102
DIO3	3	103
DIO4	4	104
EOI	5	105
DAV	6	106
NRFD	7	107
NDAC	8	108
IFC	9	109
SRQ	10	110
ATN	11	111
DIO5	13	201
DIO6	14	202
DIO7	15	203
DIO8	16	204
REN	17	205
GND*	12	112
	18	206
	19	207
	20	208
	21	209
	22	210
	23	211
	24	212

Signal name	RS232-C X722	X723
TXD	2	12
RXD	3	11
RTS	4	14
CTS	5	13
DSR	6	15
DTR	20	25
GND**	1	21
	7	22
		23
		24

* All grounds of IEEE-488 are interconnected.

** All grounds of RS232-C are interconnected.

Signal name list

Signal name	Description	Signal source	Signal destination(s)
A7SL--HT	A7 selected	A7	A7
AB01...16	Address bus 01...16	A7+A6	General
AB19	Address bus 19	A6+A7	General
ATN	Attention	A7	A66
BSBU--LT	Bus buzy	A7+A6+ Option	A7, A6, Option
BSGRINHT	Bus grant input	A6	- (1)
BSGROTHT	Bus grant output	A7	Option (2)
BSRQ--LT	Bus request	A7+A6+ Option	A7, A6, Option
CCUBSELT	CCU bus enable	A7	A7
CCURD--LT	CCU read	A7	A7
CCURQ--LT	CCU request	A7	A7
CCUTSMLT	CCU timing slave master	A7	A7
CCUWR--LT	CCU write	A7	A7
CKAB	Clock AB	A7	A7
CKIR--LT	Real time clock interrupt	A7	A7
CTS	Clear to send	A66	-
CTSCA--LT	Clear to send channel A	A7	A7
DAAK--LT	Data acknowledge	A7	A7
DAHISBLT	Data high strobe	A7+A6	A12-A3, A12-A5
DALOSBLT	Data low strobe	A7+A6	A12-A3, A12-A5
DASB--HT	Data strobe	A7	A7
DASB--LT	Data strobe	A7	A7
DATRAKLT	Data transfer acknowledge	A3+A7+A5+ A6+A8+ Option	A7, A12-A6, A12-Option
DAV	Data valid	A7	A66
DB00...15	Data bus 00...15	A7+A6	General
DIO01...08	Data I/O 01...08	A7	A66
DLIN	Delay in	A7	A7
DLOT0...3	Delay out 0...3	A7	A7
DSR	Data set ready	A7	A66
DSRCA--LT	Data set ready channel A	A7	A7
DTR	Data terminal ready	A66	-
DTRCA	Data terminal ready channel A	A7	A7
DUART--LT	Select DUART	A7	A7
ENAB	Enable AB	A7	A7
ENAD--LT	Enable address	A7	A7
ENBA--LT	Enable BA	A7	A7
ENBSOTLT	Enable bus out	A7	A7
EOI	End or identity	A7	A66
IEDIO1LT..8LT	IEEE data I/O 1...8	A7	A7
IEEE--LT	Select IEEE	A7	A7
IEIR--LT	IEEE interrupt	A7	A7

(1) Becomes BSGROTHT on unit A6

(2) Becomes BSGRINHT on option

Signal name	Description	Signal source	Signal destination(s)
IFC	Interface clear	A7	A66
IL07--LT	Interrupt level 07	A7	A12-A6
LDSWR	Lower data strobe write	A7	A7
LODASBLT	Lower data strobe	A7	A7
MASL--LT	Master selected	A7+A6+	A7,A6,Option
MYSL01LT	Memory select 01	A7+A6	A12-A5
MYSL02LT	Memory select 02	A7+A6	A12-A3,A12-A4
MYSLDWLT	Memory select down	A6	-
NDAC	Note data accepted	A7	A66
NRFD	Not ready for data	A7	A66
OKIN	OK input	A7	A7
OKOT	OK output	A7	A7
RAM---LT	Select RAM	A7	A7
RDSB--LT	Read strobe	A7	A7
REN	Remote enable	A7	A66
ROM---LT	Select ROM	A7	A7
RQB	Request B	A7	A7
RQCL	Request clock	A7	A7
RSIR--LT	RS232-C interrupt	A7	A7
RTCAS	Real time clock address strobe	A7	A7
RTCCE1LT	Real time clock chip enable 1	A7	A7
RTCCE2LT	Real time clock chip enable 2	A7	A7
RTCDS	Real time clock data strobe	A7	A7
RTCMAD0...7	Real time clock multiplexed address/data 0...7	A7	A7
RTCPS	Real time clock preset	A7	A7
RTCRS-LT	Real time clock reset	A7	A7
RTCRW	Real time clock read/write	A7	A7
RTS	Request to send	A7	A66
RTSCA--LT	Request to send channel A	A7	A7
RXD	Receive data	A66	-
RXDB	Receive data B	A7	A7
RXDCA--LT	Receive data channel A	A7	A7
RXDCA--LT	Receive data channel B	A7	A7
SEL0...2	Select 0...2	A7	A7
SRQ	Service request	A7	A66
SSW727	Service switch X727	A7	A7
SSW728	Service switch X728	A7	A7
SSW729	Service switch X729	A7	A7
SWRDIELT	Slow read IEEE	A7	A7
SWWRIELT	Slow write IEEE	A7	A7
TRWD--LT	Trigger watchdog	A7	A7
TSLMA-HT	Timing slave master	A7	A7
TSLMA-LT	Timing slave master	A7	A7
TXD	Transmit data	A7	A66
TXDB	Transmit data B	A7	A7
TXDCA--LT	Transmit data channel A	A7	A7
TXDCB--LT	Transmit data channel B	A7	A7
UDSWR	Upper data strobe write	A7	A7

Signal name	Description	Signal source	Signal destination(s)
UPAB01...23	Microprocessor address bus 01...23	A7	A7
UPADSBLT	Microprocessor address strobe	A7	A7
UPCK	Microprocessor clock	A7	A7
UPCK08	Microprocessor clock 8 MHz	A6	-
UPDASBLT	Upper data strobe	A7	A7
UPDB00...15	Microprocessor data bus 00...15	A7	A7
UPRD--LT	Microprocessor read	A7+A6	general
UPRS--HT	Microprocessor reset	A7	A7
UPRS--LT	Microprocessor reset	A7	A7
UPRSOTLT	Microprocessor reset out	A6	-
UPRW--HT	Microprocessor read/write	A7	A7
UPRW--LT	Microprocessor read/write	A7	A7
UPWR--LT	Microprocessor write	A7+A6	general
VAPEADLT	Valid peripheral address	A7	A7
VBB	Voltage battery backup	A6	-
VBBa	Voltage battery backup a	A7	A7
WD----LT	Watchdog	A7	A12-A6
WDOT--LT	Watchdog out	A7	A7
D	Digital ground	A19	-
+5 D	+5 Volt digital	A19	-
+7 V	+7 Volt	A19	-
-7 V	-7 Volt	A19	-

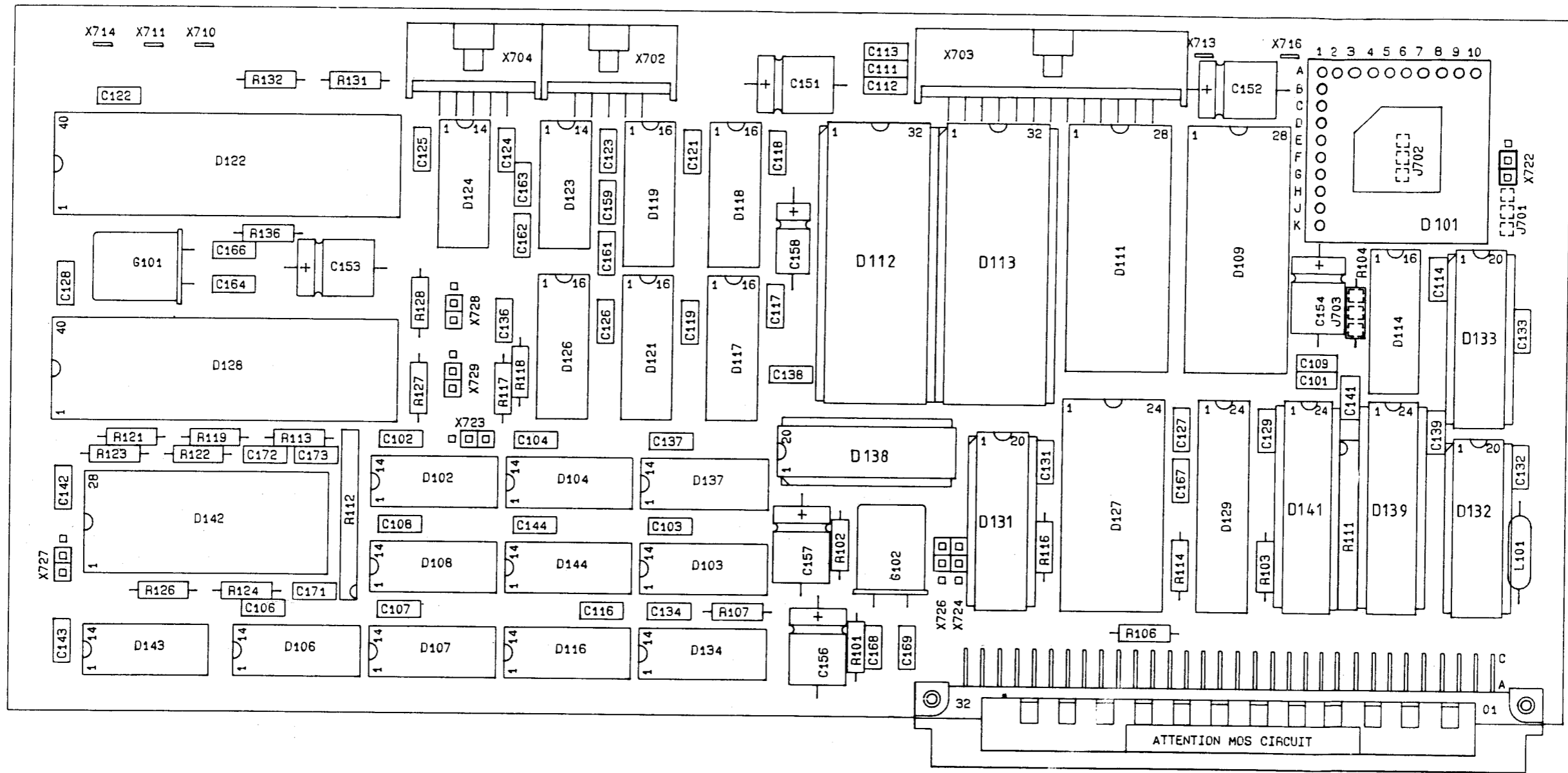

MAT 2932 A

Figure 10.5 OPTION UNIT - p.c.b. lay-out

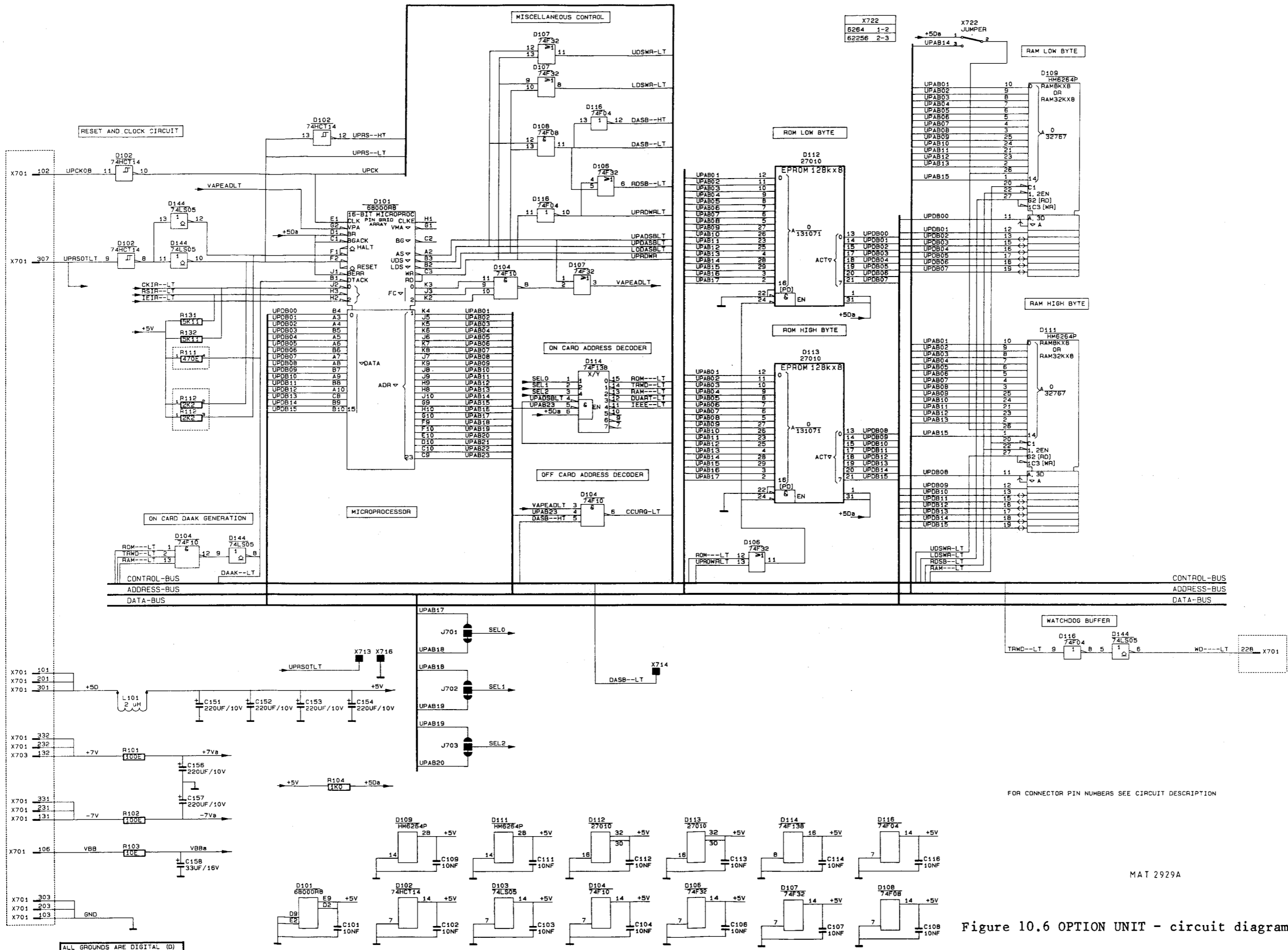

FOR CONNECTOR PIN NUMBERS SEE CIRCUIT DESCRIPTION

MAT 2929A

Figure 10.6 OPTION UNIT - circuit diagram

ALL GROUNDS ARE DIGITAL (D)

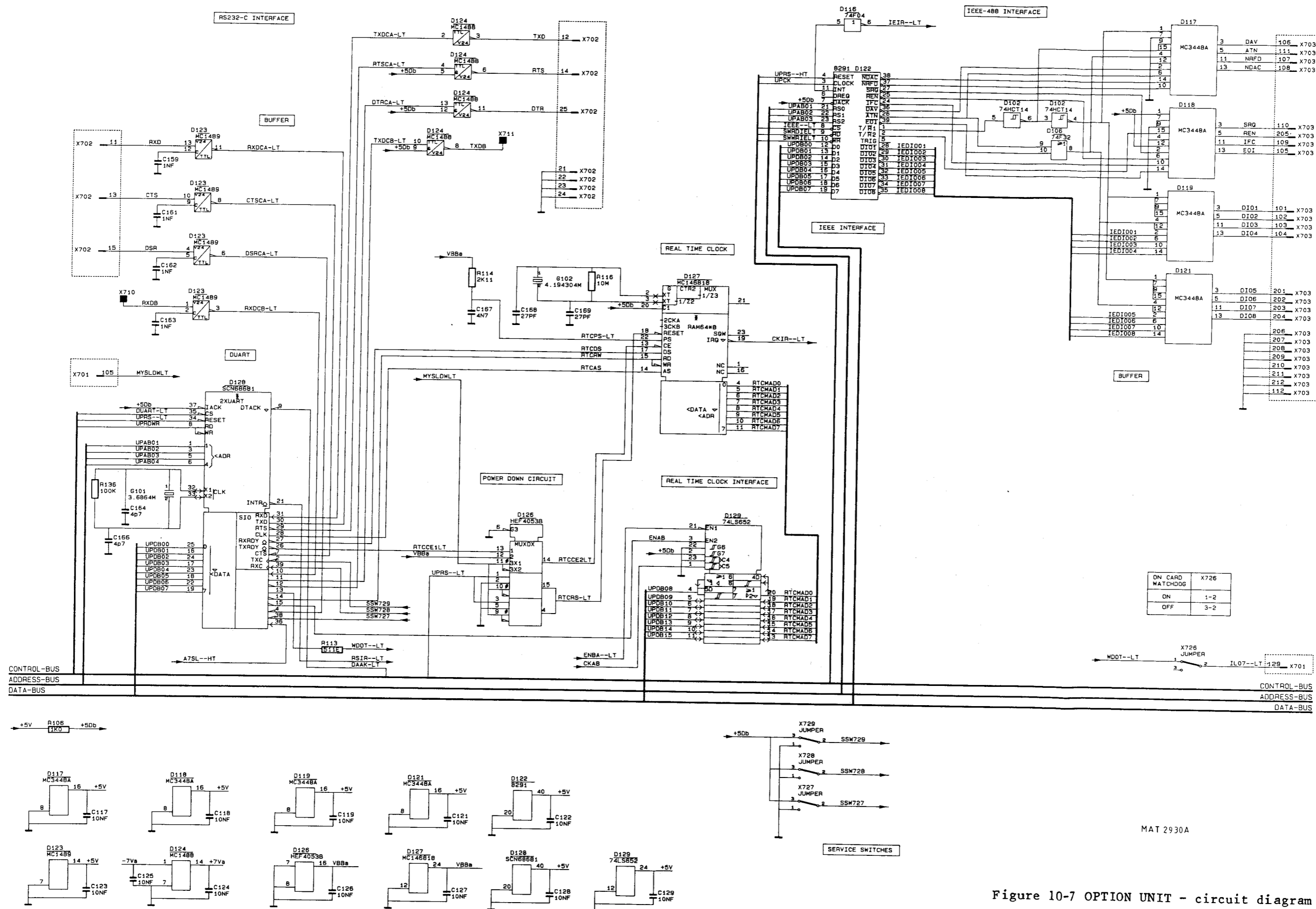

Figure 10-7 OPTION UNIT - circuit diagram

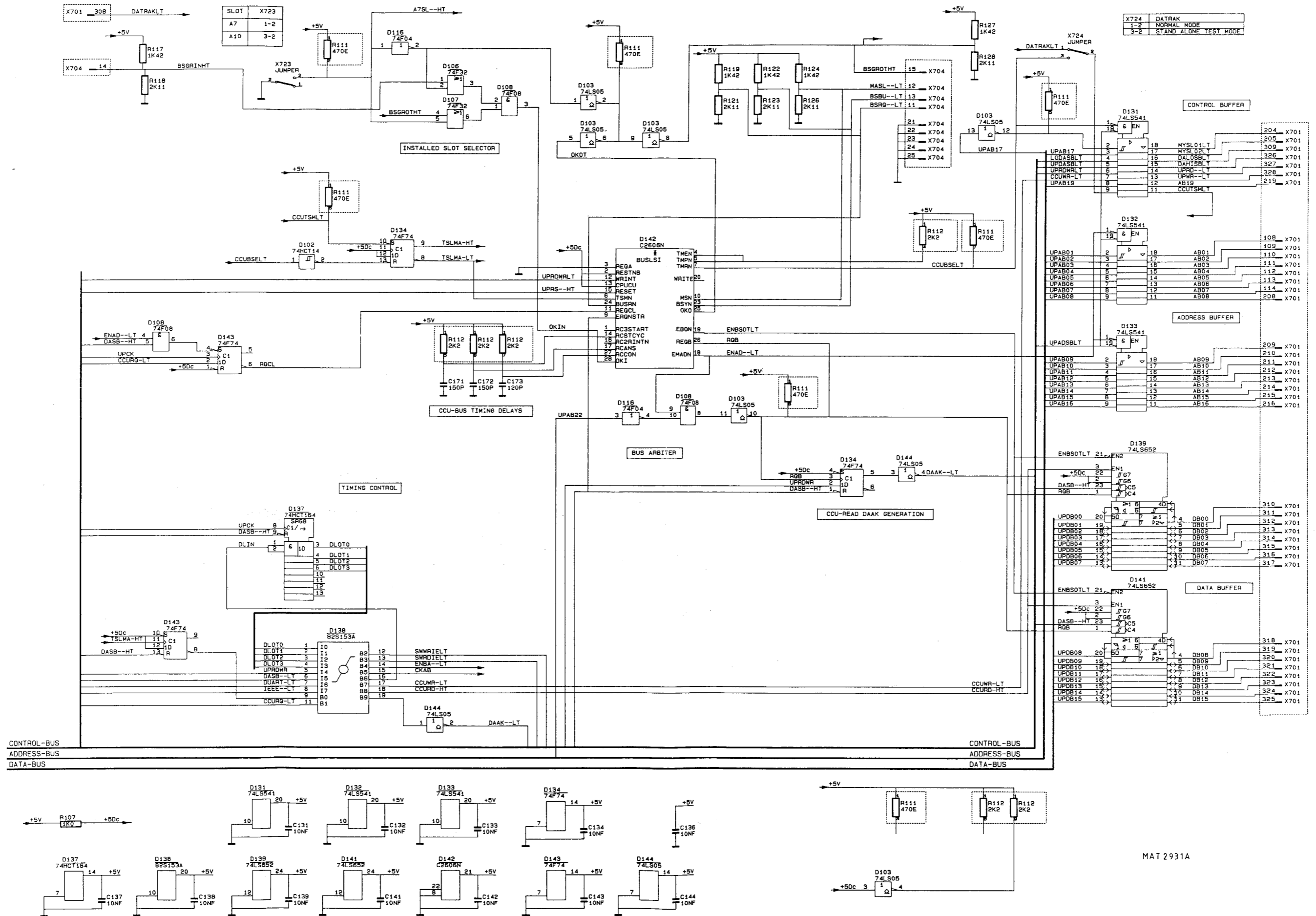

Figure 10.8 OPTION UNIT - circuit diagram

10.5 DESCRIPTION OF THE DIAGNOSTIC SOFTWARE

10.5.1 Introduction

The diagnostic software consists of two parts:

- softkey selectable diagnostic software.
- hardware selectable diagnostic software.

It is recommended to read the circuit description (section 10.4) first, before using the diagnostic software.

Each part will be described in the following subsections.

10.5.2 Softkey selectable diagnostic software

The softkey selectable diagnostic software can be used to detect faults in the setting memory and in the RS232-C interface hardware.

NOTE: The use of these routines may change or destroy the actual interface settings.

The diagnostic software can be activated if the OPTION INTERFACE menu (via the DISPLAY pushbutton) or a lower level menu is selected.

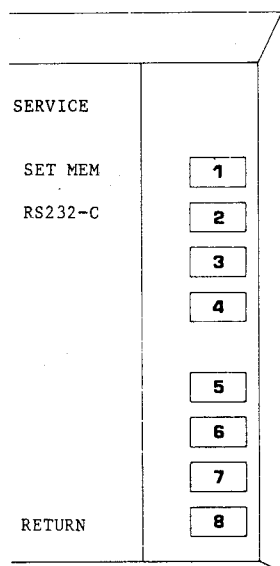

After pushing the upper and the lower softkey in the OPTION INTERFACE menu, the SERVICE menu appears on the screen. This menu allows the selection of a number of fault finding routines.

At the left side of the softkeys 3 and 4 the sum check data are displayed.

Information about the software release is displayed at the left side of the softkeys 5 to 7.

1 SET MEM

If SET MEM is selected the setting memory in the real time clock IC is tested.

If the test is completed successfully, the following message is displayed:

SET MEM test completed

If the test fails a message:

SET MEM test failed

is displayed.

2 RS232-C

If RS232-C is selected, the RS232-C interface is tested. To run this test, the following signals on connector X702 should be interconnected:

Signal	to	Signal	Flatcable wires
RXD		TXD	1 to 3
CTS		RTS	5 to 7
DSR		DTR	9 to 10

These interconnections can be made with a piece of 10-wire flatcable with one flatcable connector. The connector can be plugged into X702, while the other end can be used for interconnections and measuring.

When the test is run, the character "U" is transmitted once via TXD. Because the bit pattern of character "U" is "01010101" the level of the TXD line should change. The test is run at the baudrate which is selected via the RS232-C OUTF SPEED menu. This allows running the test at every possible baudrate. If the input and the output baudrates are different, the input baudrate is changed over to the output baudrate.

If the test is run correctly a message:

RS232-C interface test completed
is displayed.

When no data or wrong data is received via RXD, a message:

No data received
is displayed.

When no signal is received at CTS a message:

No CTS received
is displayed.

When no signal is received at DSR a message:

No DSR received
is displayed.

3 --

4 --

5 --

6 --

7 --

8 RETURN

Return to normal operation.

All settings of the interface are preset to their default values.

10.5.3 Hardware selectable diagnostic software

By changing over the service switches X728 and X729 three service routines can be selected, which are used to test the hardware. Running these tests does not influence the normal operation of the oscilloscope, as long as no actions are demanded from the option. The flatcable to unit A6 for the bus arbiter signals should be fitted anyway.

The table below gives an overview of the tests.

Test	Service X728	Switch X729
Normal operation	2-3	2-3
RAM test	1-2	2-3
Bus arbiter test	2-3	1-2
Address range test	1-2	1-2

The RAM TEST writes a certain pattern to the addresses in the RAM (D109 and D111). Next all addresses are read back. When all read data are OK the test is repeated. At testpoint X711, a square wave with a frequency of 600 Hz can be measured.

If the read data are not OK, a square wave with a frequency of 1200 Hz can be measured at X711. Also the microprocessor continuously writes and reads the address where the failure is.

If the part of the ram, that is used by this routine, is broken, then there is no signal at X711.

The BUS ARBITER TEST writes and reads continuously address C23FFE (hex), which can only be accessed via the CCU bus. So the bus arbiter is continuously activated in this test. If the read data is OK, a square wave with a frequency of 150 Hz can be measured at X711. If the data is wrong, the frequency is 300 Hz.

If there is no square wave present at X711, the routine hangs up. By checking the status of the signals described in section 9.2, the failure can be detected.

The ADDRESS RANGE TEST writes and reads in sequence the hexadecimal code 5555 to a range of addresses on this unit (address range 000000...09FFFF), followed by the same sequence with hexadecimal code AAAA.

The complete test takes about 1,4 seconds and is repeated automatically (measuring point: D114 pin 3).

Each address is read immediately after it is written. The read data are not checked. During this test all levels of the lines of the microprocessor busses (except UPAB20...UPAB23 and the CCU-bus) should change regularly.

NOTES: This test does not make UPAB23 high and so the CCU-bus is not accessed. This avoids that the microprocessor on unit A6 hangs up while this test is run.

The address lines UPAB20...UPAB23 and the CCU-bus are tested with the BUS ARBITER TEST.

10.6 SERVICE TOOLS

Extension board

For test and repair purposes the unit can be plugged in it's connector via an extension board available under codenumber 5322 216 51153.

Extension flatcable

If the unit is used with the above mentioned extension board, the flatcable has to be replaced by a longer type. This cable can be made with the following parts:

- Universal flatcable, 40 wires, length 60 cm 5322 323 50112
- 10 pole cable connector 5322 265 51117

To get the required number of 10 wires, the flatcable must be split by means of a pair of scissors or a knife.
The cable must be cut to a length of 35 cm.

The connectors can be mounted on the flatcable by means of a pair of pliers or in a bench-vice.

ATTENTION: Check the position of the flatcable in the connector before pressing the connector together.

Flatcable for RS232-C test

The flatcable with interconnections, which is used for the RS232-C test (see section 10.5.2), can be made from the same parts as the above mentioned extension flatcable.

10.7 PARTS LISTFlatcables and connectors

For the flatcables used with this unit, the required version must be made by yourself with the following parts:

- Universal flatcable, 40 wires, length 60 cm 5322 323 50112

To get the required number of wires, the flatcable must be split by means of a pair of scissors or a knife.
The cable must be cut on the required length.

- Flatcable connectors

The connectors can be mounted on the flatcable by means of a pair of pliers or in a bench-vice.

ATTENTION: Check the position of the flatcable in the connector before pressing the connector together.

The following connectors are available:	Ordering number:
10 pole cable connector	5322 265 51117
26 pole cable connector	5322 267 60164

Mechanical parts:

Qty	Description	Ordering number
2	Red p.c.b. handle	5322 401 11108
2	Pin for red p.c.b. handle	5322 402 10036
2	Spacer for fixation of RS232C connector	5322 535 92336
2	Washer for spacer	4822 530 80173
8	Nylon clamp	5322 401 11156
1	IEEE connector unit	5322 216 93939
1	RS232 cable	5322 321 22547

Electrical parts:

Qty	Description	Ordering number
1	IEEE/RS232 interface unit	5322 214 90113
1	Set of two programmed EPROM's D112 + D113	5322 310 10289

Capacitors

Item	Description	Ordering number
C 0101	100V 10% 10NF	5322 121 42495
C 0102	100V 10% 10NF	5322 121 42495
C 0103	100V 10% 10NF	5322 121 42495
C 0104	100V 10% 10NF	5322 121 42495
C 0106	100V 10% 10NF	5322 121 42495
C 0107	100V 10% 10NF	5322 121 42495
C 0108	100V 10% 10NF	5322 121 42495
C 0109	100V 10% 10NF	5322 121 42495
C 0111	100V 10% 10NF	5322 121 42495
C 0112	100V 10% 10NF	5322 121 42495
C 0113	100V 10% 10NF	5322 121 42495
C 0114	100V 10% 10NF	5322 121 42495
C 0116	100V 10% 10NF	5322 121 42495
C 0117	100V 10% 10NF	5322 121 42495
C 0118	100V 10% 10NF	5322 121 42495
C 0119	100V 10% 10NF	5322 121 42495
C 0121	100V 10% 10NF	5322 121 42495
C 0122	100V 10% 10NF	5322 121 42495
C 0123	100V 10% 10NF	5322 121 42495
C 0124	100V 10% 10NF	5322 121 42495
C 0125	100V 10% 10NF	5322 121 42495
C 0126	100V 10% 10NF	5322 121 42495
C 0127	100V 10% 10NF	5322 121 42495
C 0128	100V 10% 10NF	5322 121 42495
C 0129	100V 10% 10NF	5322 121 42495
C 0131	100V 10% 10NF	5322 121 42495
C 0132	100V 10% 10NF	5322 121 42495
C 0133	100V 10% 10NF	5322 121 42495
C 0134	100V 10% 10NF	5322 121 42495
C 0136	100V 10% 10NF	5322 121 42495
C 0137	100V 10% 10NF	5322 121 42495
C 0138	100V 10% 10NF	5322 121 42495
C 0139	100V 10% 10NF	5322 121 42495
C 0141	100V 10% 10NF	5322 121 42495
C 0142	100V 10% 10NF	5322 121 42495
C 0143	100V 10% 10NF	5322 121 42495
C 0144	100V 10% 10NF	5322 121 42495
C 0151	-10+50% 220UF	4822 124 20681
C 0152	-10+50% 220UF	4822 124 20681
C 0153	-10+50% 220UF	4822 124 20681
C 0154	-10+50% 220UF	4822 124 20681
C 0156	-10+50% 220UF	4822 124 20681
C 0157	-10+50% 220UF	4822 124 20681
C 0158	-10+50% 33UF	4822 124 20712
C 0159	10% 1NF	4822 122 30027
C 0161	10% 1NF	4822 122 30027
C 0162	10% 1NF	4822 122 30027
C 0163	10% 1NF	4822 122 30027
C 166	4.7 PF 100V	4822 122 31822
C 0167	63V 10% 220NF	5322 121 42493
C 0168	2% 27PF	4822 122 30045
C 0169	2% 27PF	4822 122 30045
C 0171	2% 150PF	4822 122 31413
C 0172	2% 150PF	4822 122 31413
C 0173	2% 150PF	4822 122 31413

Integrated circuits

Item	Description		Ordering number
D 0101	MC68000RC8	MOT	5322 209 71666
D 0102	PC74HCT14P	PEL	5322 209 11378
D 0103	SN74LS05N	T.I	5322 209 84994
D 0104	74F10PC	FSC	5322 209 81681
D 0106	74F32PC	FSC	4822 209 82133
D 0107	74F32PC	FSC	4822 209 82133
D 0108	74F08PC	FSC	5322 209 81574
D 0109	32K RAM		5322 209 72129
D 0111	32K RAM		5322 209 72129
D 0114	74F138PC	FSC	5322 209 82366
D 0116	74F04PC	FSC	5322 209 81577
D 0117	MC3448AP	MOT	5322 209 11317
D 0118	MC3448AP	MOT	5322 209 11317
D 0119	MC3448AP	MOT	5322 209 11317
D 0121	MC3448AP	MOT	5322 209 11317
D 0122	P8291A	INT	5322 209 81264
D 0123	MC1489AL	MOT	5322 209 86103
D 0124	MC1488L	MOT	5322 209 84307
D 0126	PC74HCT4053P		4822 209 71584
D 0127	MC146818P	MOT	5322 209 71537
D 0128	SCN68681C1N40		5322 209 11561
D 0129	SN74LS652N	T.I	5322 209 71654
D 0131	SN74LS541N	T.I	5322 209 71671
D 0132	SN74LS541N	T.I	5322 209 71671
D 0133	SN74LS541N	T.I	5322 209 71671
D 0134	74F74PC	FSC	5322 209 81474
D 0137	PC74HCT164P	PEL	5322 209 11268
D 0138	SAM FPLA		5322 209 51393
D 0139	SN74LS652N	T.I	5322 209 71654
D 0141	SN74LS652N	T.I	5322 209 71654
D 0142	C2606NQD	SIG	5322 209 86197
D 0143	74F74PC	FSC	5322 209 81474
D 0144	SN74LS05N	T.I	5322 209 84994

Crystals

Item	Description		Ordering number
G 0101	CRYSTAL 3686.400 KHZ		5322 242 71867
G 0102	CRYSTAL 4194.304 KHZ		5322 242 70454

Coils

Item	Description		Ordering number
L 0101	2.2UH	TDK	4822 157 51757

Resistors

Item	Description	Ordering number
R 0101	MRS25 1% 100E	5322 116 53126
R 0102	MRS25 1% 100E	5322 116 53126
R 0103	MRS25 1% 10E	4822 116 52891
R 0104	MRS25 1% 1K	4822 116 53108
R 0106	MRS25 1% 1K	4822 116 53108
R 0107	MRS25 1% 1K	4822 116 53108
R 0111	-105-471 470E	5322 111 90462
R 0112	-105-222 2K2	5322 111 90826
R 0113	MRS25 1% 511E	5322 116 53135
R 0114	MRS25 1% 1M	4822 116 52843
R 0116	VR25 5% 10M	4822 110 72214
R 0117	MRS25 1% 1K47	5322 116 53185
R 0118	MRS25 1% 2K15	5322 116 53239
R 0119	MRS25 1% 1K47	5322 116 53185
R 0121	MRS25 1% 2K15	5322 116 53239
R 0122	MRS25 1% 1K47	5322 116 53185
R 0123	MRS25 1% 2K15	5322 116 53239
R 0124	MRS25 1% 1K47	5322 116 53185
R 0126	MRS25 1% 2K15	5322 116 53239
R 0127	MRS25 1% 1K47	5322 116 53185
R 0128	MRS25 1% 2K15	5322 116 53239
R 0131	MRS25 1% 5K11	5322 116 53494
R 0132	MRS25 1% 5K11	5322 116 53494
R 0136	MTL FILM RST 100K 1%	4822 116 52973

Connectors

Item	Description	Ordering number
X 0701	96-P PEN 2.54	5322 265 61029
X 0702	10-P DBL RT.ANG	5322 265 51188
X 0703	26-P DBL RT.ANG	5322 265 61135
X 0704	10-P DBL RT.ANG	5322 265 51188
X 0720	24P SQR IEEE	5322 267 60162
X 0720	25-P PIN DIPS	4822 266 51009
X 0721	P RECHT QF50	5322 265 51186
X 0721	10-P DBL RT.ANG	5322 265 51188
X 0721	3-P SNG 12.45	5322 265 30392
X 0721	2-P	5322 263 60062
X 0722	P RECHT QF50	5322 265 51186
X 0723	P RECHT QF50	5322 265 40642